



aerospace
climate control
electromechanical
filtration
fluid & gas handling
hydraulics
pneumatics
process control
sealing & shielding



Industrial Drive Products

AC Drives, DC Drives, Motors,
Options & Accessories



ENGINEERING YOUR SUCCESS.



WARNING – USER RESPONSIBILITY

FAILURE OR IMPROPER SELECTION OR IMPROPER USE OF THE PRODUCTS DESCRIBED HEREIN OR RELATED ITEMS CAN CAUSE DEATH, PERSONAL INJURY AND PROPERTY DAMAGE.

- This document and other information from Parker-Hannifin Corporation, its subsidiaries and authorized distributors provide product or system options for further investigation by users having technical expertise.
- The user, through its own analysis and testing, is solely responsible for making the final selection of the system and components and assuring that all performance, endurance, maintenance, safety and warning requirements of the application are met. The user must analyze all aspects of the application, follow applicable industry standards, and follow the information concerning the product in the current product catalog and in any other materials provided from Parker or its subsidiaries or authorized distributors.
- To the extent that Parker or its subsidiaries or authorized distributors provide component or system options based upon data or specifications provided by the user, the user is responsible for determining that such data and specifications are suitable and sufficient for all applications and reasonably foreseeable uses of the components or systems.

Table of Contents

OVERVIEW

Parker Hannifin.....	4
Total Life-Cycle Support.....	6

AC DRIVES..... 7

Variable Speed AC Drives.....	8
Variable Speed Drive - AC10 Series.....	11
Variable Speed Drive - AC30 Series.....	25
High Performance Modular Systems Drive - AC890 Series.....	47
High Power AC Variable Speed Drive - AC890PX-M Series Modular Chassis Drive.....	71

DC DRIVES..... 97

Variable Speed DC Drives.....	98
Analogue DC Drives - 506/507/508 Series.....	100
Analogue DC Drives - 512C Series.....	101
Analogue DC Drives - 514C Series.....	102
Variable Speed DC Drives - DC590+ Integrator Series 15 A - 2700 A.	103
HMI Touchscreen - TS8000.....	123

MOTORS

Square Frame Three-Phase Induction Motors - MS Series Motor 0.75 kW - 524 kW.....	131
Round Frame Three-Phase Induction Motors - MR Series Motor 0.09 kW - 315 kW.....	145
Sensorless Servo Motors - NX Series.....	153
Torque Motors - TMW Series.....	154

SPECIALIST SYSTEMS

Fastpack.....	155
Parker's Drive Systems Build Capabilities.....	159

Parker Hannifin

The global leader in motion and control technologies and systems

Global Partnerships Global Support

Parker is committed to helping make our customers more productive and more profitable through our global offering of motion and control products and systems. In an increasingly competitive global economy, we seek to develop customer relationships as technology partnerships. Working closely with our customers, we can ensure the best selection of technologies to suit the needs of our customers' applications.

Electromechanical Technologies for High Dynamic Performance and Precision Motion

Parker electromechanical technologies form an important part of Parker's global motion and control offering. Electromechanical systems combine high performance speed and position control with the flexibility to adapt the systems to the rapidly changing needs of the industries we serve.

aerospace
climate control
electromechanical
filtration
fluid & gas handling
hydraulics
pneumatics
process control
sealing & shielding



Parker Hannifin Corporation

With annual sales exceeding \$13 billion in fiscal year 2013, Parker Hannifin is the world's leading diversified manufacturer of motion and control technologies and systems, providing precision-engineered solutions for a wide variety of mobile, industrial and aerospace markets. The company employs approximately 58 000 people in 49 countries around the world.

Parker has increased its annual dividends paid to shareholders for 57 consecutive fiscal years, among the top five longest-running dividend-increase records in the S&P 500 index. For more information, visit the company's website at www.parker.com, or its investor information website at www.phstock.com.

Issue: 08/2013

Electromechanical Automation

Global products with local manufacturing and support

Global Product Design

Parker Hannifin has more than 40 years experience in the design and manufacturing of drives, controls, motors and mechanical products. With dedicated global product development teams, Parker draws on industry-leading technological leadership and experience from engineering teams in Europe, North America and Asia.

Local Application Expertise

Parker has local engineering resources committed to adapting and applying our current products and technologies to best fit our customers' needs.

Manufacturing to Meet Our Customers' Needs

Parker is committed to meeting the increasing service demands that our customers require to succeed in the global industrial market. Parker's manufacturing teams seek continuous improvement through the implementation of lean manufacturing methods throughout the process. We measure ourselves on meeting our customers' expectations of quality and delivery, not just our own. In order to meet these expectations, Parker operates and continues to invest in our manufacturing facilities in Europe, North America and Asia.

Electromechanical Worldwide Manufacturing Locations

Europe

Littlehampton, United Kingdom
Dijon, France
Offenburg, Germany
Filderstadt, Germany
Milan, Italy

Asia

Wuxi, China
Chennai, India

North America

Rohnert Park, California
Irwin, Pennsylvania
Charlotte, North Carolina
New Ulm, Minnesota



Offenburg, Germany

Local Manufacturing and Support in Europe

Parker provides sales assistance and local technical support through a network of dedicated sales teams and authorized technical distributors throughout Europe.

For contact information, please refer to the Sales Offices on the back cover of this document or visit www.parker.com



Milan, Italy



Littlehampton, UK



Filderstadt, Germany



Dijon, France

Total Life-Cycle Support



Pre-Sales

- Catalogues
- Brochures
- On-Line Tools
- Selection Tools



Spares/Repairs

- Product Warranty
- Authorised Repair Centres
- Parker Repair Centre



Training

- Customer Site Training
- Parker Site Training
- On-line training

Application Support

- Solutions Approach
- Engineering knowledge
- Application expertise
- Product expertise

Customer



Where to Buy

- Global availability
- Wide distribution network
- European stocking



Installation/Commissioning

- Electrical installation
- Commissioning and start-up
- Free telephone support



AC Drives

Variable Speed AC Drives

Range Overview 0.2 kW - 2,000 kW

Global AC Drive Solutions to Improve Productivity and Save Energy

Parker's range of AC drives are designed to meet the needs of today's engineering challenges and provide excellence in motor speed and torque control. With drive solutions for simple control, through multi-motor process line applications and all the way up to high power grid-tied power conversion systems, Parker's drive technologies are built upon the principles of Simplicity, Reliability, Flexibility and Capability.



AC10 Series Micro Drive

- Conveyors
- Automatic barriers
- Machine spindles
- Mixers
- Fans



AC30 Series Standard Drive

- Centrifugal pumps & fans
- Hydraulic power units (HPU)
- Wire drawing
- Converting machines



AC890 Series High Performance Drive

- Printing machinery
- Converting machinery
- Test equipment
- Power generation
- Marine applications



Variable Speed AC Drives

Range Overview 0.2 kW - 2000 kW

Global AC Drive Solutions to Improve Productivity and Save Energy

Parker assists its customers in improving productivity and reducing energy consumption with a comprehensive, range of AC drives and drive systems. Parker AC drive products are sold, supported and serviced worldwide, with solutions from simple speed control to complex coordinated process control. Parker AC drive products are easy to configure and commission, with simple but flexible function block-based configuration tools and connectivity with all major industrial fieldbus networks.

Energy Savings Using Variable Speed Drive Technology

The application of variable speed drives to traditional fixed speed applications, such as in pumps, fans and compressors, can yield up to 30 % energy savings. In fact, many power utilities and government agencies provide financial incentives to invest in VSD technology. Parker's General Purpose AC drives make these savings possible.

Improving Process Productivity and Reliability

Parker AC drive products also have the functionality, designed and refined from decades of experience, to provide the precise, coordinated speed control, often among multiple motor axes, to ensure process line success. With high speed communication, easy to use configuration tools and HMI control solutions, Parker AC drives can handle the most complex process control applications.

Clean Power for Additional Energy Savings

Parker's AC drive products are frequently to be found at the heart of clean power solutions through Active Front End and line regeneration technology, producing additional energy savings through power factor control.

AC Drives Product Range Overview

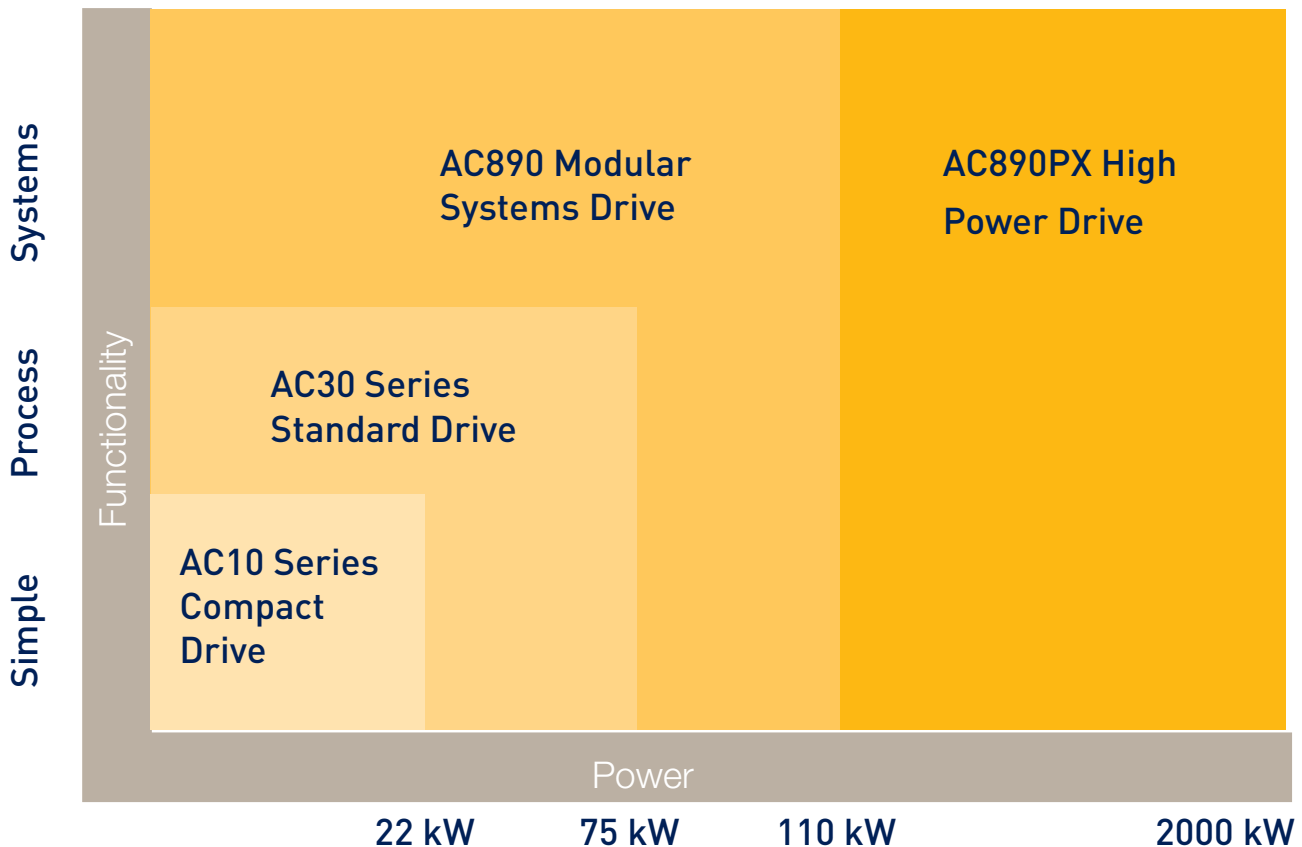

AC10 Series Compact Drive 0.2 - 22 kW

AC10 Compact Drive is a simple, reliable and economical solution to every-day motor control applications requiring speed or torque control within the power range of 0.2 kW to 22 kW. Having compact dimensions and features normally only associated with higher specification drives, including, sensorless vector mode, output frequency up to 590 Hz, 1 and 3 phase, 200 and 400 V supplies with 150 % overload for 1 minute and 200% for 3 seconds.



AC30 Series Standard Drive 0.75 - 75 kW

AC30 drive has been designed to provide users with exceptional levels of control, from simple open-loop pumps and fans through to closed-loop process line applications. Its flexible and highly modular construction enables a wide range of communications and I/O modules to be easily added as required.

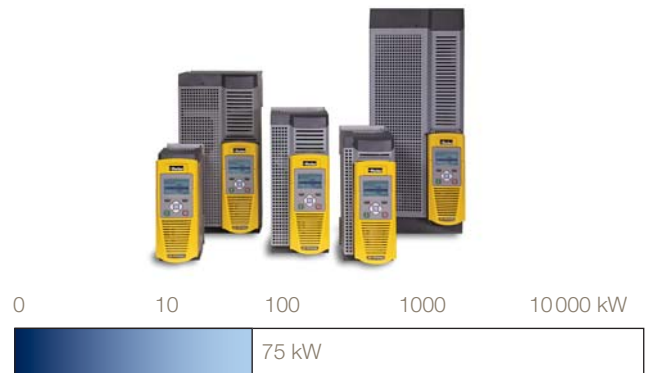

AC890 Series High Performance Drive 0.55 - 315 kW

The AC890 Series is a range of modular AC drives, designed to minimize space and maximize performance in multiple axes applications. This AC890 Series can provide torque, speed and position control and can be configured to control permanent magnet servo motors in addition to induction motors. Available as stand-alone or common bus DC modules.



AC890PX Series High Power Drive 110 - 2,000 kW

The AC890PX is a high power modular systems drive designed for industrial and power conversion applications. Available as a standalone drive or as part of a high power drive system, the AC890PX features removable phase and control modules, which allow for simple servicing and flexible system design. Power output to 2 MW.

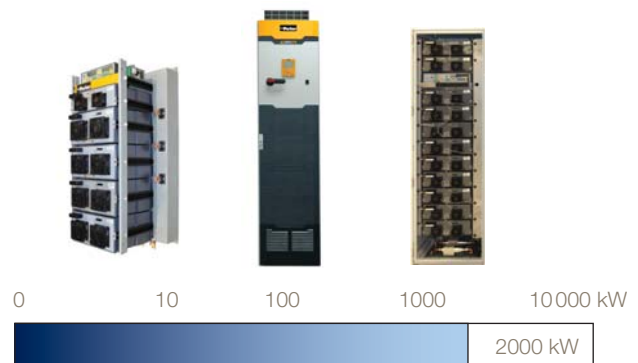

Technical Notes

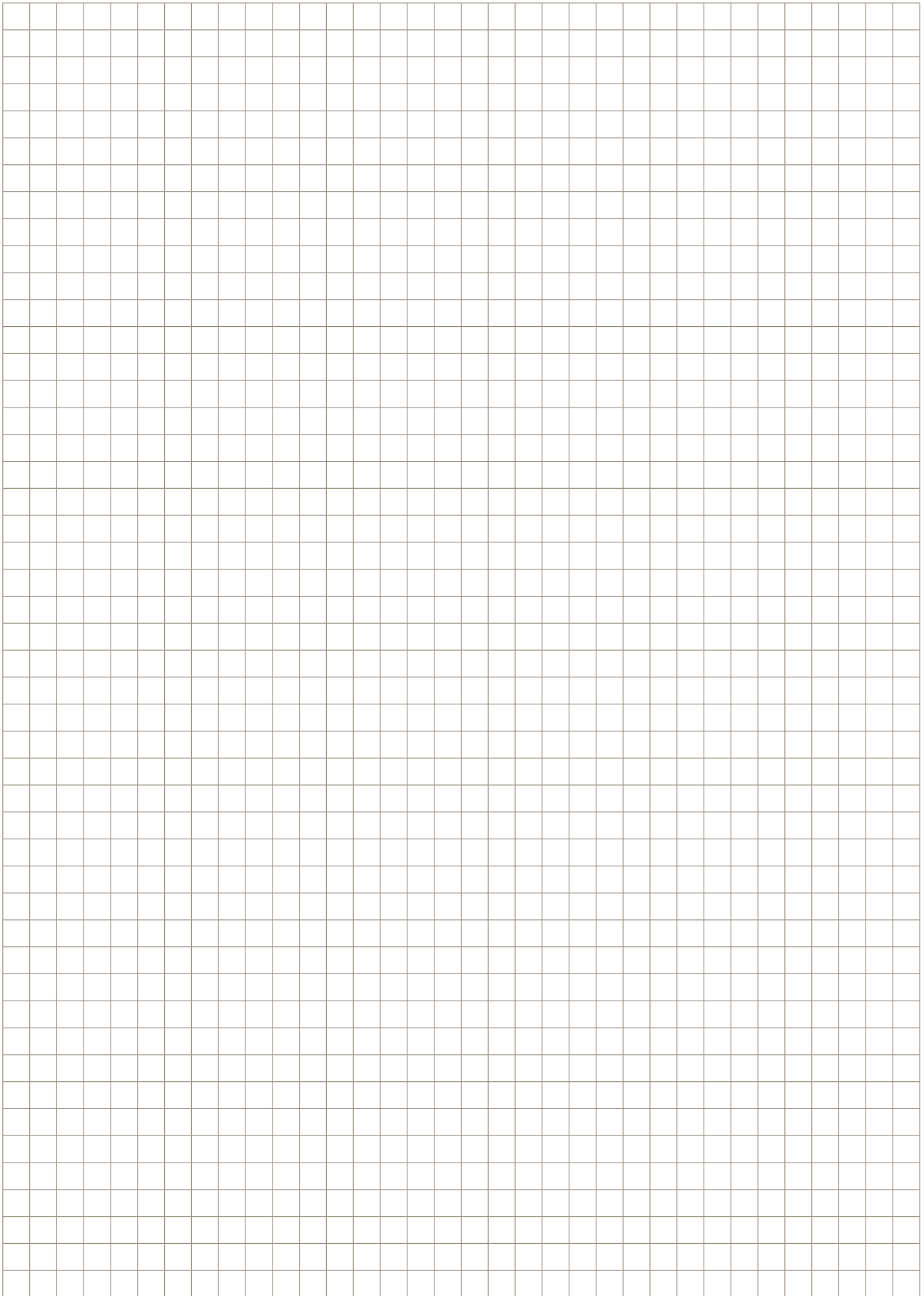

Variable Speed Drive - AC10 Series

Overview

Description

The AC10 Compact Drive is a simple, reliable and economical solution to every-day motor control applications requiring speed or torque control within the power range of 0.2 kW to 22 kW. Having compact dimensions and features normally only associated with higher specification drives, including, sensorless vector mode for control of Permanent Magnet (PMA) and AC induction motors, output frequency up to 590 Hz, 3 phase 400 V supplies in all 5 frame sizes and a full 150 % overload at 0.5 Hz for 1 minute, AC10 provides an optimised solution for OEM machine builders looking for a compact, cost-effective drive without compromising on performance.

Features

Simplicity

AC10 is designed to reduce the time and effort required to install, setup and commission through its easy to use integrated keypad. Minimal wiring requirements and two easily accessed terminal rails make AC10 fast and simple to install, having you up and running in no time at all. Auto-tuning sensorless vector mode takes AC10 beyond simple V/Hz control allowing users requiring greater dynamic speed or torque control for their application to benefit from the drives enhanced 0.5 % speed and 5 % torque accuracy.

Reliability

Proven technology and manufacturing techniques ensure AC10 has been engineered and built to deliver consistently outstanding levels of performance day in, day out ensuring maximum uptime and productivity. Thanks to its conformally coated PCBs, AC10 is able to withstand even the most arduous class 3C3 environment which many other drives in this class would struggle with, allowing you to operate AC10 with the utmost confidence in more applications



Technical Characteristics - Overview

Power Supply	220 ... 240 VAC ±15 % Single Phase 220 ... 240 VAC ±15 % Three Phase 380 ... 480 VAC +10 % -15 % Three Phase
Input Frequency	50/60 Hz
Power Range	0.2...22 kW
Operating Temperature	0...40 °C
Protection	IP20
Analogue Inputs	2x (0-10 V, 0-5 V, 0-20 mA, 4-20 mA)
Analogue Outputs	1x (0-10 V, 0-20 mA)
Digital Inputs	5x 24 VDC
Digital Outputs	1x 24 VDC
Relay Output	1x 5 A @230 VAC



IE2 Efficiency MR Series AC Induction Motors

An ideal complement to AC10, the MR Series AC Induction motors are IE2 efficient and start from a power range of 0.09 kW. Featuring optional axial in-line force ventilation fan and holding brake, the MR motor is a high quality durable AC motor which when matched to the AC10 will provide you with a complete motor/drive package that will deliver optimal performance in your application.

AC10 Drives Range

One of the smallest compact-drives available and with five different frame sizes covering a power range of 0.2 kW through to 22 kW, AC10 is a low-cost, compact solution for simple AC induction motor control in a wide range of applications across a host of different industries.

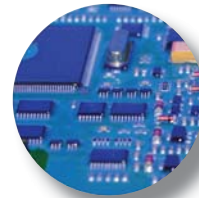

Suited to all environments

- Optional Internal EMC filter allows use in C3 industrial environments
- Conformal coating provides protection in arduous class 3C3 environments
- Global availability and support
- 50 °C operating temperature
- Fan-cooled heatsink, convection cooled electronics



Flexible I/O

- Freely assignable digital inputs and outputs, and relay output to suit your application needs
- 1 analogue output and 2 analogue inputs for connection to speed potentiometers and panel meters
- Internal dynamic brake switch as standard



Modbus/RS485 communication

- Connection to Parker PDB drive setup and monitoring tool
- Connection to PLC or other Modbus RTU / RS485 network



Extra power when it's needed

- 150 % overload for 60 seconds at 0.5 Hz to provide extra starting torque for shifting high inertia loads
- Output power can be uprated for operation in lower ambient temperatures



Simple or enhanced performance

- Simple V/Hz control for general energy saving applications
- Enhanced auto-tuning sensorless vector control providing higher dynamic performance for applications requiring greater speed or torque accuracy
- Sensorless PMAC & AC Induction Motor control



All at the touch of a button

- Standard ergonomic keypad providing full access to all drive functions
- 4 LEDs provide instant indication of drive status
- Remote mountable keypad option for ease of setup and operation



Simplified Setup

- Simple out of the box operation thanks to integrated macros and quick start guide
- Basic speed control
- Speed preset
- Raise / Lower
- Auto / Man
- PID control
- Essential services (Fire Mode)
- Catch a spinning load (Fly-Catching)



High Speed Operation

- Up to 590 Hz output for high speed operations such as spindles, centrifuges, mixers etc.

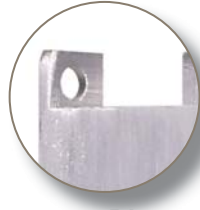

Compact Dimensions

- When compared to other compact drives of similar functionality, AC10 is noticeably more compact reducing cabinet space and freeing up valuable floor space.



Control at your fingertips

AC10 comes complete with an ergonomic operator keypad as standard featuring 4 LED drive status indicators, a 4 digit 7 segment LED display and a tactile membrane style keypad.

In addition to displaying status and running information, the LED display is also used to access drive configuration parameters which can be quickly and easily changed via the keypad.

The keypad can also be used to take local control of the motor to start, stop, increase or decrease motor speed.

An optional keypad is also available and can be mounted remotely from the drive.

Sensorless Permanent Magnet (PMAC) Motor Control

AC10 is capable of providing control of any sensorless PMAC motor, such as the Parker NX series. Servo motor technology can deliver up to 10 % more energy savings than conventional induction motors and can also be up to 75 % smaller in size.

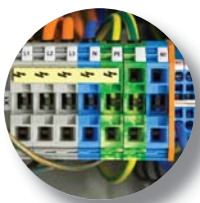

Choice of operating voltages

- 230 V single and three phase input up to 2.2 kW
- 400 V three phase input from 0.2 kW through to 22 kW

Applications

AC10 provides a no-fuss approach to general purpose industrial motor control applications across a wide range of industries, giving users the benefits of the inherent energy-saving properties of using a variable speed drive, as well as the improved reliability and extended service life benefits associated with smoother starting and stopping of regularly cycling loads.

Typical applications for AC10 include...

- Conveyor
- Centrifuge
- Fans
- Mixers
- Packaging Machines
- Textile Machines
- Strapping Machines
- Labelling Machines
- Industrial Washing Machines
- Machine Tool Spindles
- Roller Doors



Conveyors

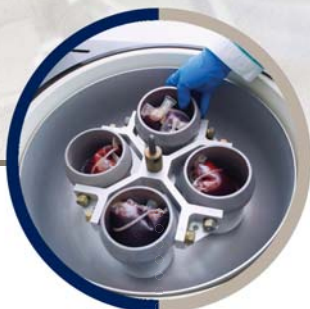

Centrifuges



Fans



Mixers



Packaging Machines



Textile Machines

Technical Characteristics

Power Ratings

230 V Single Phase Input / 230 V Three phase Input		
Nominal Power [kW]	Output Current [A]	Frame Size
0.2	1.5	1
0.4	2.5	1
0.55	3.5	1
0.75	4.5	1
1.1	5	2
1.5	7	2
2.2	10	2

400 V Three phase Input		
Nominal Power [kW]	Output Current [A]	Frame Size
0.2	0.6	1
0.4	1	1
0.55	1.5	1
0.75	2	2
1.1	3	2
1.5	4	2
2.2	6.5	2
3	8	3
4	9	3
5.5	12	3
7.5	17	4
11	23	4
15	32	5
18.5	38	5
22	44	5

Electrical Characteristics

Power Supply	220 ... 240 VAC $\pm 15\%$ Single Phase 220 ... 240 VAC $\pm 15\%$ Three Phase 380 ... 480 VAC $+10\%$ -15% Three Phase
Rated Input Frequency	50/60 Hz
Maximum Switching Frequency	10 kHz without derating
Overload	150% of Rated Current for 60s, 200% for 2s
Output Frequency	0.5...590 Hz
Switching Frequency	2...10kHz selectable
Control Mode	Volts/Hertz or Sensorless Vector (SLV) Mode
Earth Leakage Current	>10 mA (all models)

Environmental Characteristics

Temperature range	Operating Temperature: 0...+50 °C, derate above 40 °C
Humidity	Operating humidity: Below 90 % Relative Humidity, non-condensing
Vibration	Below 0.5 g
Altitude	1000 m ASL
Protection Degree	IP20
Chemically Active Substances	For the standard product, compliance with EN60271-3-3 is Class 3C3

Standards and Conformance

Overvoltage Category	Overvoltage category III (numeral defining an impulse withstand level)
EMC Compatibility	Meets the requirements of IEC/EN61800-3 : 2004 “Adjustable speed electrical power drive systems – Part 3”
European Certification	This product conforms with the Low Voltage Directive 2006/95/EC
North American Certification	Complies with the requirements of UL508C and CSA 22.2 #14 as an open type drive

Dimensions

Dimensions [mm]

AC10				
Frame	Height (H)	Width (W)	Depth (D)	Weight [kg]
1	138	80	135	1.25
2	180	106	150	1.76
3	235	138	152	2.96
4	265	156	170	4.9
5	340	205	196	7.5

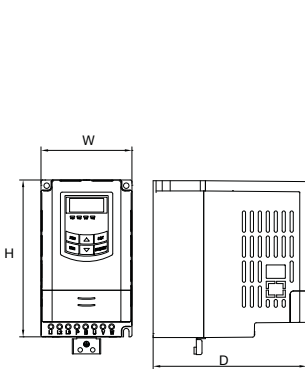

Frame 1

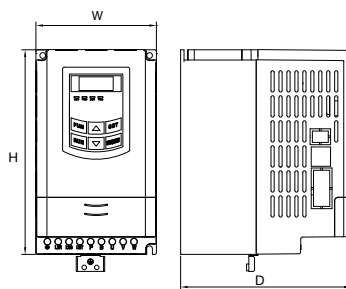

Frame 2

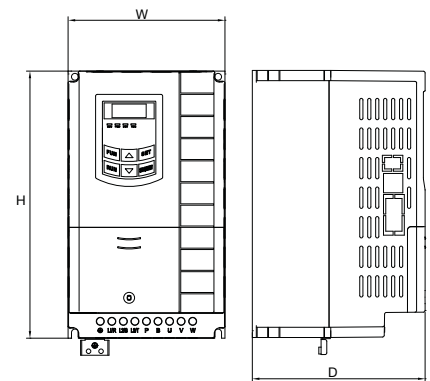

Frame 3

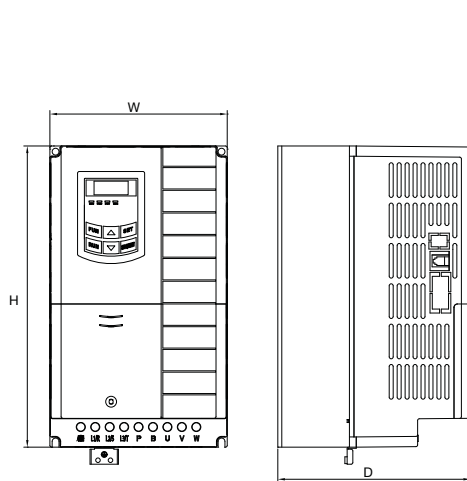

Frame 4

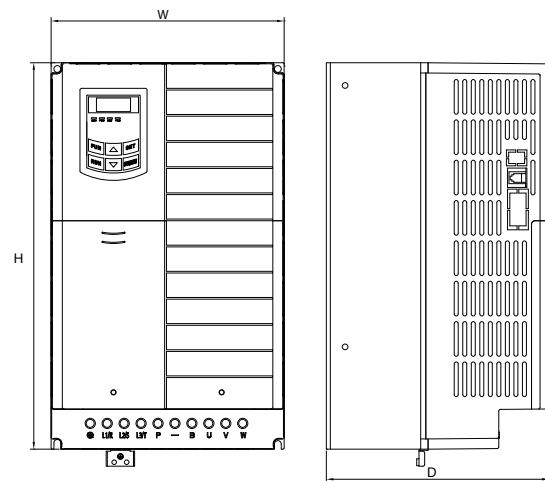

Frame 5

Connections

Terminal	Description
L1/R	Single or three phase input L1
L2/S	Single or three phase input L2
L3/T	Three phase input L3
P	Braking Resistor
B	Braking Resistor
U	Motor Output 1/U
V	Motor Output 2/V
W	Motor Output 3/W

Terminal	Description
TA	Alarm N/O Relay Contact 5 A 24 VDC
TB	Alarm N/C Relay Contact 5 A 24 VDC
TC	Drive Alarm Common
DO1	Digital Output 1
24V	24 VDC Digital Output (max 50 mA)
CM	0 V DC Common
DI1	Digital Input 1
DI2	Digital Input 2
DI3	Digital Input 3
DI4	Digital Input 4
DI5	Digital Input 5
10V	10 V Reference supply (max 20 mA)
AI1	Analogue input 1
AI2	Analogue input 2
GND	Power Supply 0 V
AO1	Analogue Output
A+	RS485 Channel A
B-	RS485 Channel B

- Analogue Inputs 2: (0-10 V, 0-5 V, 0-20 mA, 4-20 mA)
- Analogue Output 1: (0-10 V, 0-20 mA)
- Digital Inputs 5: Nominal 24 VDC
- Digital Output 1: Nominal 24 VDC
- Relay Output 1: Volt free contact, 5 A @230 VAC max.

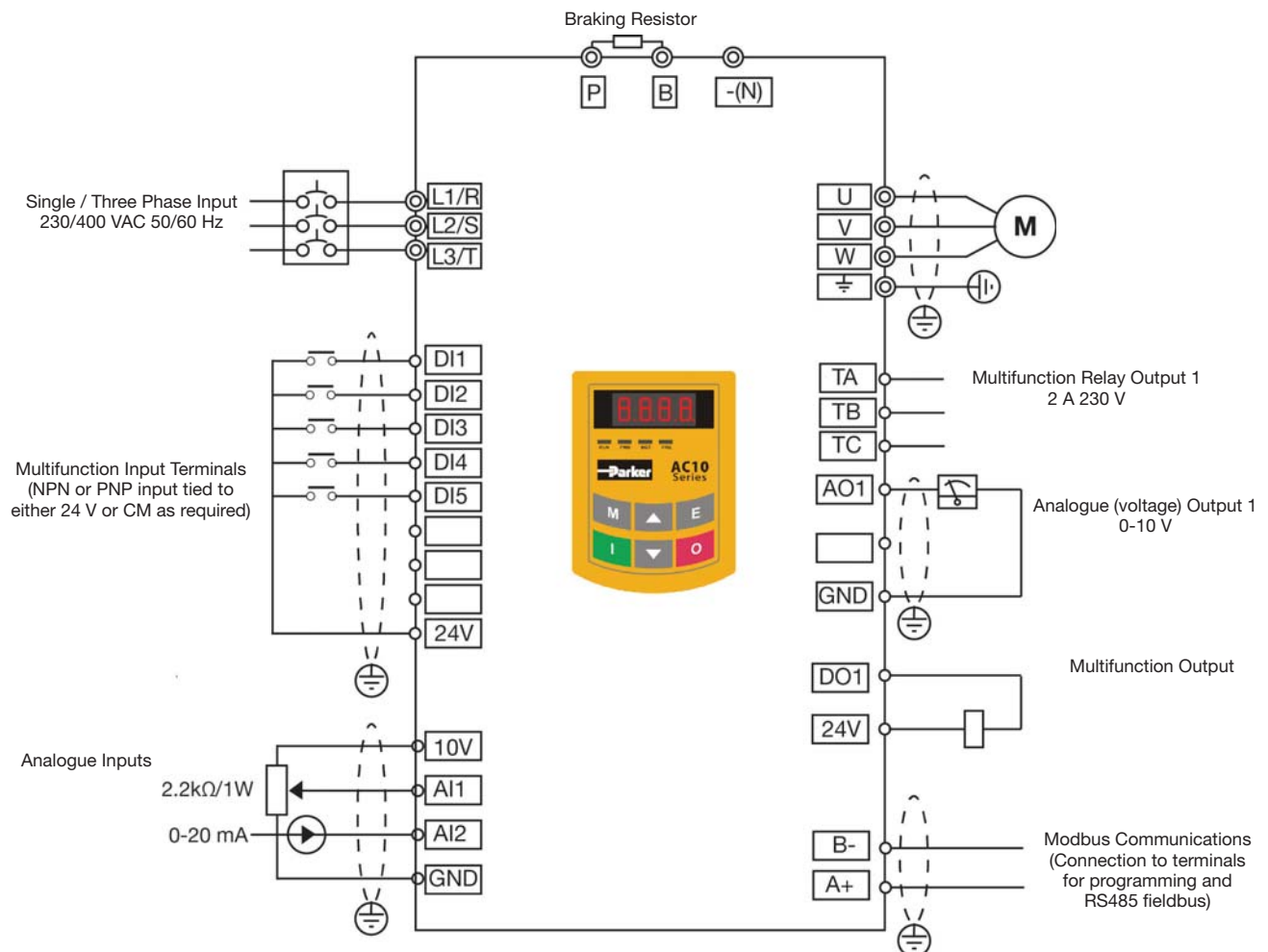

Accessories and Options

Remote Mounting Keypad

The remote mounting keypad allows users to mount the keypad away from the drive, such as on the door of an electrical enclosure, allows users to configure, operate and monitor the drive without having to access the drive directly.

The remote keypad provides the same functionality as the drive mounted keypad and is connected to the drive via a 1.5 m cable plugged into the port on the left hand side of the drive.



Order Code	Description
1001-00-00	Remote Keypad

Software - Parker Drive Basic (PDB)

Free Configuration and Diagnostic Monitoring Software

Parker Drive Basic is a monitoring and configuration software tool for use with AC10 Variable Speed Drives. Parker Drive Basic is available as a free download from the Parker website.

Connecting to the AC10 over Modbus, Parker Drive Basic enables users to import, modify and export drive parameters as well as providing a convenient means of starting, stopping and monitoring the operation of the drive.

Note: a USB/RS485 adapter is required to enable connection between PC and drive.

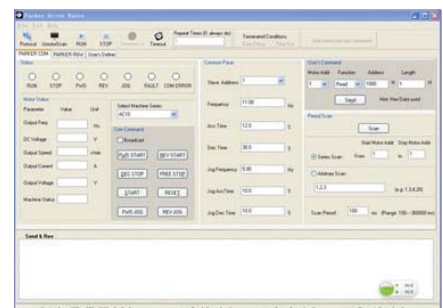
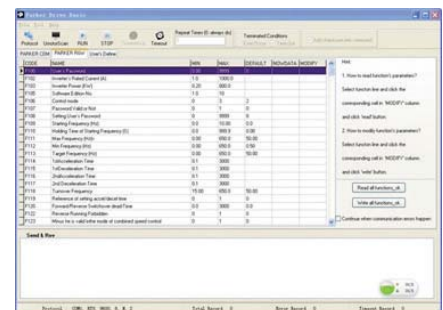

Braking Resistor

During deceleration, or with an over-hauling load, the motor acts as a generator. Energy flows back from the motor into the DC link capacitors within the drive, causing their voltage to rise. If this voltage exceeds a maximum value, the drive will trip to protect the capacitors and internal power devices. The amount of energy that can be absorbed by the capacitors can vary between different applications causing the drive to trip on overvolts. To increase the drive's dynamic braking capability, high power resistor(s), connected across the DC link, allow the dissipation of this excess energy for short term stoppage or braking.



Brake resistor selection

Brake resistor assemblies must be rated to absorb both peak braking power during deceleration and the average power over the complete cycle.

$$\text{Peak braking power} = \frac{0.0055J \times (n_1^2 - n_2^2) (W)}{t_b}$$

$$\text{Average braking power } P_{av} = \frac{P_{pk} \times t_b}{t_c}$$

J: total inertia [kgm²]
n₁: initial speed [min⁻¹]
n₂: final speed [min⁻¹]
t_b: braking time [s]
t_c: cycle time [s]

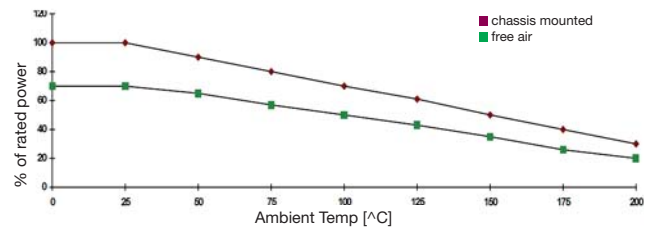

Resistors above 500 W







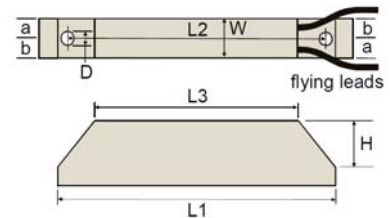









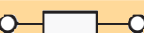







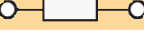

Resistors above 500 W are available upon request :

- IP20 protection up to 3 kW
- IP13 protection between 4.2 and 9.8 kW

Model	Impedance [Ω]	Nom. Power [W]	Dimensions [mm]							
			L1	L2	L3	W	H	D	a	b
CZ467715	500	60	100	87	60	22	41	4.3	10	12
CZ467714	200	100	165	152	125	22	41	4.3	10	12
CZ389853	100	100	165	152	125	22	41	4.3	10	12
CZ467717	100	200	165	146	125	30	60	4.3	13	17
CZ463068	56	200	165	146	125	30	60	4.3	13	17
CZ388397	56	200	165	146	125	30	60	4.3	13	17
CZ388396	36	500	335	316	295	30	60	4.3	13	17
CZ467716	28 x 2	500	335	316	295	30	60	4.3	13	17



Overload 5 s : 500 %
Overload 3 s : 833 %
Overload 1 s : 2500 %

Power Rating [kW]	R1 Resistor Order Code	R2 Resistor Order Code	Connected	Minimum resistance [Ω]	Braking Power [W]
230 V Single Phase					
0,2	CZ467717	-		60	150
0,37	CZ467717	-		60	150
0,55	CZ467717	-		60	150
0,75	CZ467717	-		60	150
1,1	CZ467717	-		60	150
1,5	CZ467717	-		60	150
2,2	CZ467717	-		60	150
230 V Three Phase					
0,37	CZ467717	-		60	150
0,55	CZ467717	-		60	150
0,75	CZ467717	-		60	150
1,1	CZ467717	-		60	150
1,5	CZ467717	-		60	150
2,2	CZ467717	-		60	150
400 V Three Phase					
0,2	CZ467715	-		500	80
0,37	CZ467715	-		500	80
0,55	CZ467715	-		500	80
0,75	CZ467714	-		200	80
1,1	CZ467714	-		150	80
1,5	CZ467714	-		150	80
2,2	CZ467714	-		150	150
3	CZ467714	-		150	150
4	CZ467714	-		150	150
5,5	CZ467716	CZ467716		120	250
7,5	CZ388396	CZ388396		120	500
11	CZ467716	CZ467716		90	1000
15	SY-004655	-		80	1500

Note: The above resistors are only provided as a guide. Please use our calculation guide to confirm accurate braking resistor requirements.

Output Choke

To reduce capacitive currents and prevent nuisance tripping in installations with longer cable runs, a choke may be fitted to the drives output in series with the motor.

Order Code	Motor Power Normal Duty [kW]	Choke Inductance [mH]	Current [A _{rms}]
CO55931	1.1	2	7.5
	1.5		
	2.2		
	3.0		
CO57283	4.0	0.9	22
	5.5		
	7.5		
CO57284	11	0.45	33
	15		
CO57285	18.5	0.3	44
	22		



EMC Filter

A range of custom designed optional EMC (Electromagnetic Compatibility) filters are available for use with AC10. They are used to help achieve conformance with EMC directive BS EN61800-3.

AC10 can be ordered with an EMC filter fitted that meets the requirements of a class C3 environment. For class C2 or C1 environments, please contact your local sales office.

Order Code

AC10

	1	2		3	4		5		6	7
Order example	10	G	-	1	1	-	0015	-	B	N

1	Device Family	
10	AC10 Variable Speed Drive	
2	Industry	
G	General Purpose	
3	Voltage	
1	230 V Single Phase	
3	230 V Three Phase	
4	400 V Three Phase	
4&5	Frame Size & Rating	
230 V Supply		
1	0015	0.2 kW
1	0025	0.37 kW
1	0035	0.55 kW
1	0045	0.75 kW
2	0050	1.1 kW
2	0070	1.5 kW
2	0100	2.2 kW
400 V Supply		
1	0006	0.2 kW
1	0010	0.37 kW
1	0015	0.55 kW
2	0020	0.75 kW
2	0030	1.1 kW
2	0040	1.5 kW
2	0065	2.2 kW
3	0080	3.0 kW
3	0090	4.0 kW
3	0120	5.5 kW
4	0170	7.5 kW
4	0230	11 kW
5	0320	15 kW
5	0380	18.5 kW
5	0440	22 kW
6	Braking Module	
B	Braking Module Fitted	
7	EMC Filter	
N	No Filter Fitted	
F	C3 EMC Filter Fitted	

Technical Notes

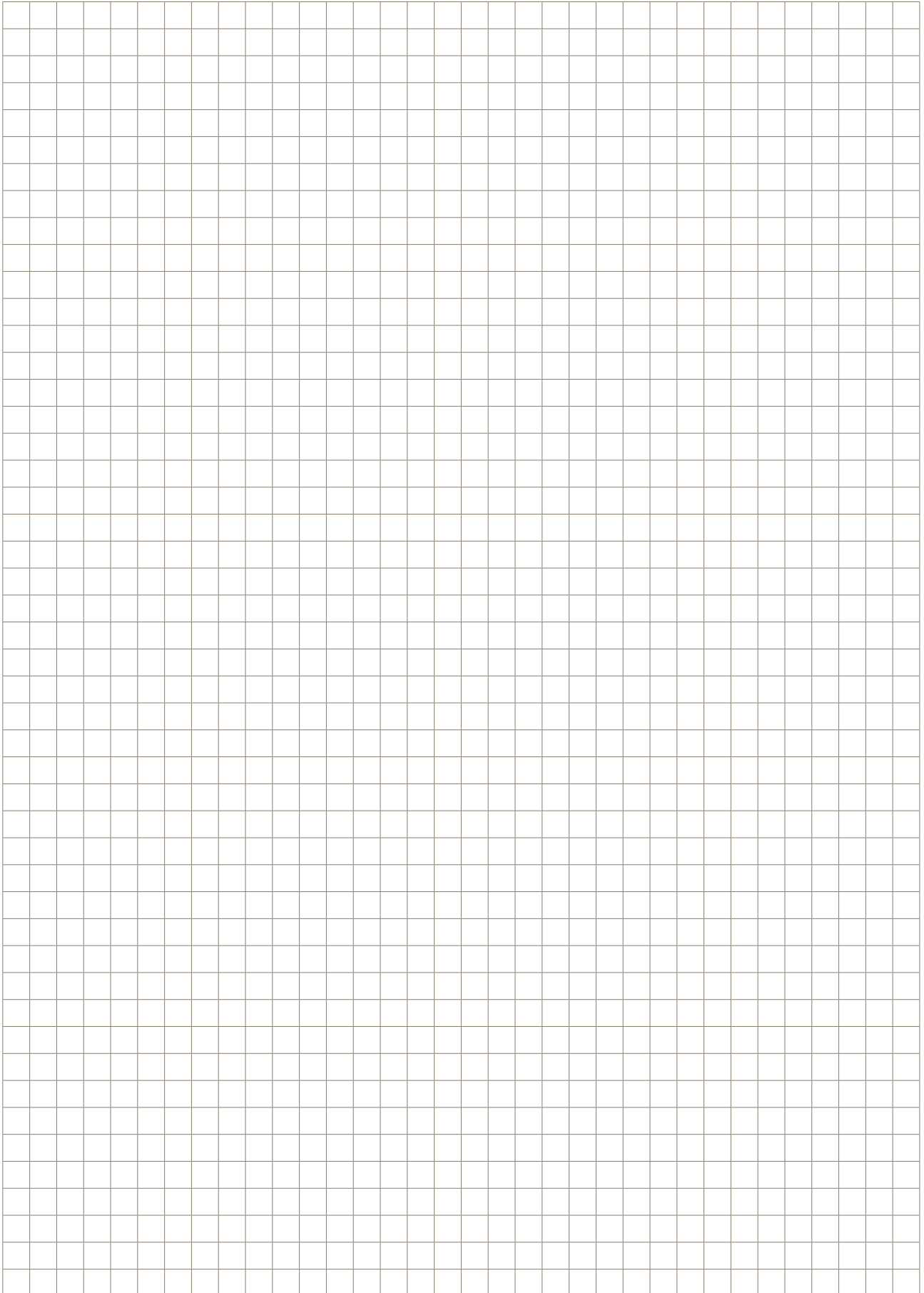
A large grid of graph paper for technical notes, consisting of 20 columns and 30 rows of small squares.

Variable Speed Drive - AC30 Series

Overview

Description

AC30 variable speed drive has been designed to provide users with exceptional levels of control, from simple open-loop pumps and fans through to closed-loop process line applications. Its flexible and highly modular construction enables a wide range of communications and I/O modules to be easily added as required.

The AC30 has been designed with simplicity in mind, but this doesn't compromise its functionality. Integrated macros for a range of applications and PLC functionality enable more capable users to create sophisticated control that would previously have required a separate PLC.

Designed for operation in environment class 3C3 and 3C4 for Hydrogen Sulphide (H₂S) as standard (tested at 25 ppm for 1200 hours), temperatures up to 50 °C with optional integrated EMC filter to C2 1st environment and DC link choke to reduce line harmonics. AC30V also complies with RoHS substance restrictions in accordance with EC Directive 2011/65/EU

Features

Flexibility

- Open-loop or optional closed-loop operation with pulse encoder feedback module
- Suitable for operation with AC induction and Permanent Magnet AC (PMA) servo motors
- Ethernet TCP/IP as standard
- I/O expansion options
- Support for popular industrial fieldbuses
- Chassis or through-panel mount as standard

Simplicity

- Advanced control with Parker Drive Developer (PDD) software tool
- Multi-language graphical keypad
- Quick start wizards
- Terminal covers removable with drive in-situ

Reliability

- Conformally coated for harsh environment protection as standard
- Spring clamp control terminal connections
- Isolated power stack cooling with removable fan



Technical Characteristics - Overview

Ratings									
380-480 (±10 %) VAC Supplies Three Phase									
Normal Duty					Heavy Duty				
kW	hp	Output Current [A _{rms}]		kW	hp	Output Current [A _{rms}]		Frame	
		400 V	480 V			400 V	480 V		
1.1	1.5	3.5	3.0	0.75	1	2.5	2.1	D	
1.5	2	4.5	3.4	1.1	1.5	3.5	3.0	D	
2.2	3	5.5	4.8	1.5	2	4.5	3.4	D	
3	4	7.5	5.8	2.2	3	5.5	4.8	D	
4	5	10	7.6	3	4	7.5	5.8	D	
5.5	7.5	12	11	4	5	10	7.6	D	
7.5	10	16	14	5.5	7.5	12	11	E	
11	15	23	21	7.5	10	16	14	E	
15	20	32	27	11	15	23	21	F	
18.5	25	38	36	15	20	32	27	F	
22	30	45	40	18.5	25	38	36	G	
30	40	60	52	22	30	45	40	G	
37	50	73	65	30	40	60	52	G	
45	60	87	77	37	50	73	65	H	
55	75	105	96	45	60	87	77	H	
75	100	145	124	55	75	105	96	H	

Designed with you in mind

Throughout every stage of the design process, our engineering teams worked to equip the AC30 with a wealth of features that benefit both OEMs and End-users alike.

Working with the three principles of Flexibility, Simplicity and Reliability, our engineers have created a product that not only delivers class-leading performance but also offers excellent usability in a host of motor control applications.

Flexibility (F)

A fully featured list of standard functionality along with the use of common control and option modules allows users to put the drive to work in many different open- or closed-loop applications without having to invest significant time and effort in re-engineering motor control systems.

Simplicity (S)

From the clear and concise backlit LCD display to the power terminal covers that can be removed with the drive in the cabinet, AC30 has been engineered to make the process of operating and maintaining the drive as easy as possible.

Reliability (R)

Although no one can guarantee problems will never happen, our engineers have taken every possible step to reduce the likelihood of them occurring, as well as including a number of features in the AC30 that will ensure any loss of productivity is minimised and production restarted as safely and as soon as possible.



Engineered cooling improves reliability

- Intelligent design minimises force ventilation requirements (R)
- Removable fan improves maintainability (R)
- Isolated power stack cooling path reduces contamination of control electronics (R)



Unobstructed access to power and dynamic brake terminals

- Terminal covers removable with drive in-situ (S)
- Dynamic brake switch fitted as standard (F)
- Easy access to DC Bus connections (S)



Suitable for harsh environments

- AC30 is conformally coated as standard and meets the requirements of environment classes 3C1, 3C2 (all defined substances) plus 3C3 and 3C4 for Hydrogen Sulphide (H₂S) (F)(R)



Suited to all environments

- Internal EMC filter options up to C2 1st environment for use in commercial buildings (F)
- CE marked to EN61800-5-1 and NRTL listed to UL508C and C22.2#14 (F)(R)
- DC link chokes above 2.2 kW reduce harmonics to below IEC/EN61000-3-12 limits (F)(R)



Compact footprint, chassis or through-panel mounting

- Multi-position feet with keyhole slots for ease of mounting (F)(S)
- Reduced heat radiation allows side-by-side mounting (F)



Expandable I/O capabilities

- A range of option modules expand AC30 to accommodate application specific I/O (F)
- High-performance, closed-loop control with pulse encoder feedback module (F)
- Spring clamp terminals reduce installation time and risk of loose connections (S)(R)

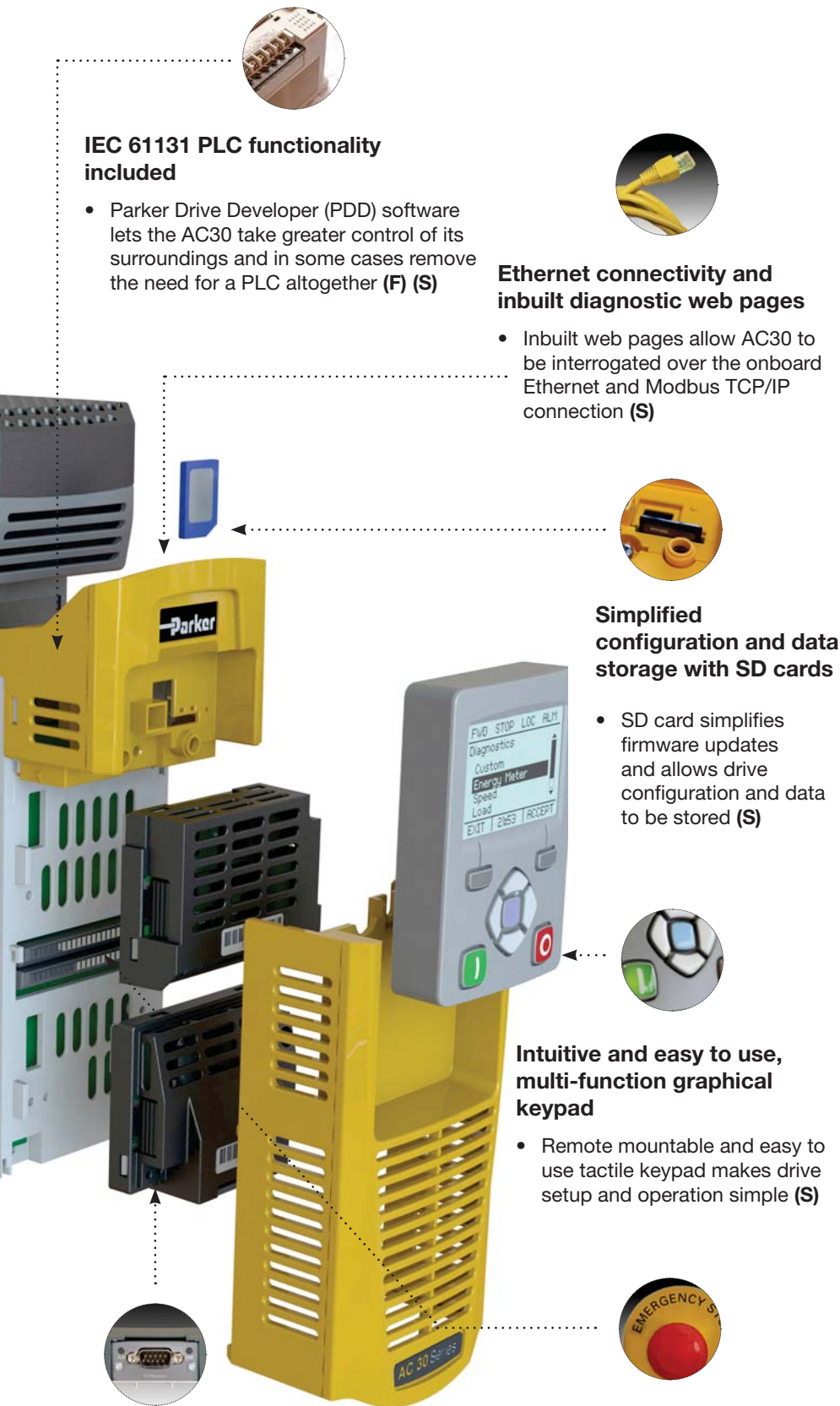

Graphical keypad

The tactile IP55 keypad can be mounted either on the drive itself or remotely and provides access to all drive functions.

The backlit LCD display can be configured to present information in any one of a number of different languages, or even in your own custom language with your own user-defined units.

Simple setup wizard and macros

- Integrated quick start wizards means you don't have to be an expert to configure the drive within minutes
- Dedicated macros and integrated function blocks simplify the creation of specific motor control applications

Keypad Remote Mounting

The graphical keypad can be mounted remotely to the drive with the use of a connecting cable. When remote mounting, a blanking cover can be fitted to the drive in place of the keypad.



Simple and effective pump and fan control



Saving energy through speed control

Pumps and fans are widely used throughout industry. Some estimates suggest that a large proportion of these can be as much as 20 % oversized for the application they are used in. When these are operated at a constant speed, a significant amount of the power consumed by the motor is wasted, costing your company considerable amounts of money and creating additional CO₂ emissions.

Matching the speed of pumps and fans to process demands with the AC30V ensures that the motor will always operate at the optimal speed to deliver just the right amount of air or fluid. This can result in significant energy savings. A 20 % reduction in speed will actually reduce energy consumption by almost 50 % and payback can be achieved in **less than 18 months in many cases.**

Speed control = Savings

- Up to 50 % energy savings
- Improved power factor
- Reduced maintenance
- Quieter operation
- Increased service life
- Reduced carbon footprint

Improved power factor and service life

Pumps and fans that continuously operate at maximum speed inevitably have shorter life spans and are subject to unnecessary wear and tear. Variable speed drives can help improve service life while also reducing energy consumption and improving the power factor of your installations.

In addition to the cut in energy costs, you'll also see significant savings with maintenance and repair bills and a noticeable reduction in noise pollution as well.

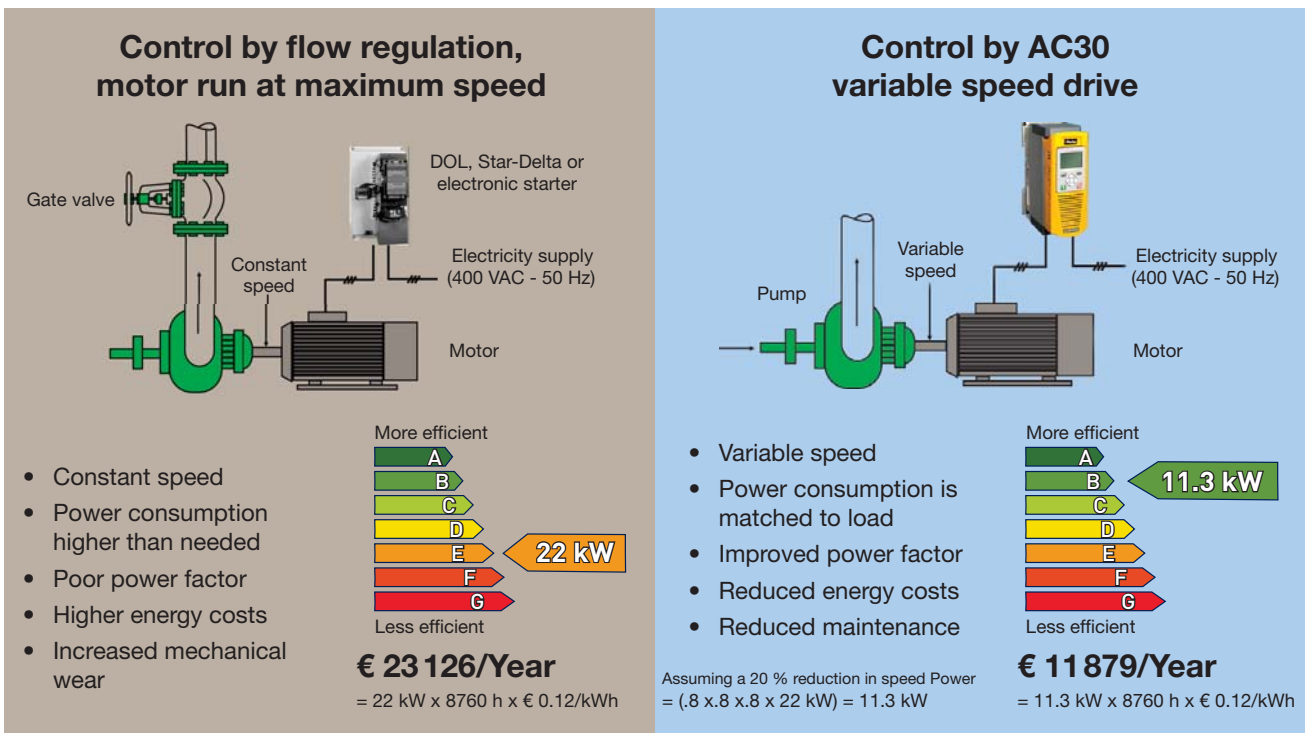

Total annual energy saving = € 11 247

Designed to put you in control of your energy savings

AC30 is supplied complete with a raft of features designed to simplify pump and fan control. In addition to quick setup, dedicated pump and fan macros, there are a number of other features dedicated to energy-saving pump and fan control such as:

Automatic belt breakage detection

Interactive monitoring of the running conditions of a fan allows AC30 to detect a breakage in the drive belt between the fan and motor, stop the motor and indicate an alarm condition.

Catching a spinning load - "fly-catching"

The fan control algorithms enable the AC30 to detect when a fan is free-wheeling and to regain control of it before running it at the commanded speed.

PID Control

Multiple PID control loops can be programmed to monitor process variables and adjust the speed of the motor accordingly to achieve the required variable setpoint.

Intelligent pump profiles

Our advanced intelligent pump control algorithms monitor motor loads and provides users with a number of features designed specifically for pump control applications, such as:

- Pump dry running protection
- Flow detection (low and no-flow)
- Blocked pump detection

Essential services (Fire mode)

Selected via digital input, Fire mode will cause the drive to run continuously at the maximum programmed speed ignoring all other control signals and alarm conditions.

Energy optimisation

Under constant speed conditions, the motor power waveforms from the drive are optimised to reduce motor energy consumption without compromising performance.

Skip frequencies

Up to 4 speed and frequency bands can be programmed in the AC30, to enable resonant points on the fan to be avoided, reducing vibration, wear and noise.

Timed run function

10 daily start/stop events can be programmed with different running speeds across a 7 day period. This function requires the optional Real Time Clock (RTC) module and is ideally suited to applications where regular operating patterns or periods of activity need to be accommodated, such as in a production environment.

Process Timers

Multiple hours-run timers can be programmed to generate text alerts on the drive keypad to coincide with process maintenance intervals.



Engineered for any motor

In addition to the energy-saving associated with VSD control of pumps and fans. Additional energy saving can be achieved by using permanent magnet (PMAC) servo motors. AC30 offers effective and affordable control of either AC induction motors or PMAC motors.

PMAC motors are up to 10% more efficient and 75% smaller than standard AC induction motors



Closed-loop operation

An optional pulse encoder feedback module can be added to the AC30 for applications requiring more accurate speed or torque control of AC induction motors



Application Macros

Making use of pre-defined control logic, application macros enables users to quickly configure the AC30 for control of one of a number of pre-defined functions. Information is presented to the user in a template format which can then be simply and easily populated with the specific details of the application. This removes the complexity of designing the application logic from scratch.

Basic Speed Control

Set speed and voltage or current with start / stop direction control



Automatic/Manual Control

Set to run with local speed setting or external reference

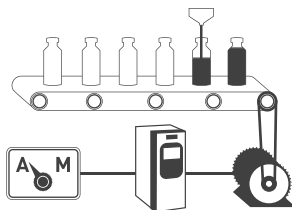

Preset Speed Control

Select up to 8 pre-programmed speeds using digital inputs

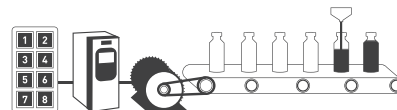

Raise / Lower

Increase or reduce speed using digital inputs

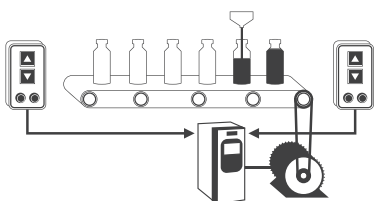

PID Control

Control the pressure, flow, temperature or any process variable

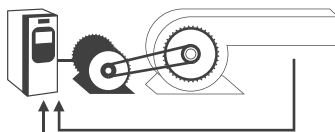

Torque Control

Control the motor torque limit using an analogue input

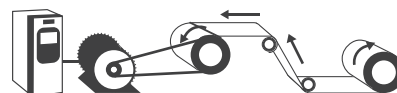

Fan Control

Dedicated fan control with specific fan functionality



Pump Control

Dedicated pump control with specific pump functionality

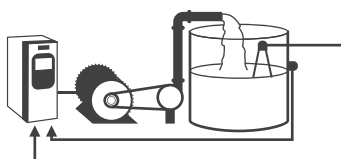

Hydraulic Pump Applications

Efficient control of hydraulic pump applications, including accumulator charging, pressure control, flow control

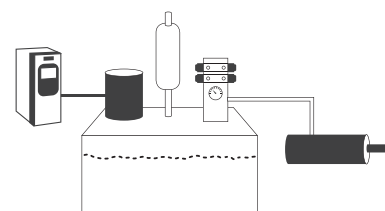

Applications

With 40 years experience of designing and building AC and DC drives and systems, Parker has a wealth of expertise in a host of different industries. The AC30 has been built on this experience and incorporates many flexible and innovative features, making it ideally suited for use in many industrial and commercial applications. Additional communications, expanded I/O and pulse encoder feedback option modules extend the capabilities of the AC30 still further, making it an extremely flexible and capable solution for all types of open- and closed-loop motor control requirements.

Typical applications for AC30 include...

- Industrial Pumps
- Industrial Fans
- Conveyor Control
- Air Compressors
- Machine Spindles
- Hydraulic Power Units
- Wire Drawings
- Converting Machines



Industrial Pump Control



Industrial Fan Control



Conveyor Control



Air Compressor Control



Machine Spindle



Hydraulic Pump Control

Technical Characteristics

Power Ratings

Order Code	Normal Duty Ratings			Heavy Duty Ratings			Frame
	kW/HP	Output Current A_{rms}		kW/HP	Output Current A_{rms}		
		400 VAC	480 VAC		400 VAC	480 VAC	
380-480 (± 10 %) VAC Supplies Three Phase							
31V-4D0004-B...	1.1/1.5	3.5	3.0	0.75/1	2.5	2.1	D
31V-4D0005-B...	1.5/2	4.5	3.4	1.1/1.5	3.5	3.0	D
31V-4D0006-B...	2.2/3	5.5	4.8	1.5/2	4.5	3.4	D
31V-4D0008-B...	3/4	7.5	5.8	2.2/3	5.5	4.8	D
31V-4D0010-B...	4/5	10	7.6	3/4	7.5	5.8	D
31V-4D0012-B...	5.5/7.5	12	11	4/5	10	7.6	D
31V-4E0016-B...	7.5/10	16	14	5.5/7.5	12	11	E
31V-4E0023-B...	11/15	23	21	7.5/10	16	14	E
31V-4F0032-B...	15/20	32	27	11/15	23	21	F
31V-4F0038-B...	18/25	38	36	15/20	32	27	F
31V-4G0045-B...	22/30	45	40	18/25	38	36	G
31V-4G0060-B...	30/40	60	52	22/30	45	40	G
31V-4G0073-B...	37/50	73	65	30/40	60	52	G
31V-4H0087-B...	45/60	87	77	37/50	73	65	H
31V-4H0105-B...	55/75	105	96	45/60	87	77	H
31V-4H0145-B...	75/100	145	124	55/75	105	96	H

See Ordering Information for full order codes and description

Electrical Characteristics

Power Supply	400 V Nominal
Rated Input Voltage	3 x 380...480 VAC ±10 %
Input Frequency	45...65 Hz
Maximum Switching Frequency	4 kHz up to maximum of 12 kHz - de-rating may apply
Overload: Heavy Duty	150 % for 60 s - 180 % for 3 s
Overload: Normal Duty	110 % for 60 s - 180 % of HD FLC. for 3 s
Output Frequencies	0...500 Hz at 4 kHz switching frequency 0...1000 Hz at 8 kHz switching frequency 0...1500 Hz at 12 kHz switching frequency
Earth Leakage Current	>10 mA (all models)

Environmental Characteristics

Operating Temperature	0...+40 °C Normal Duty, 0...+45 °C Heavy Duty. Derate up to a maximum of +50 °C
Storage Temperature	-25...+55 °C
Shipping Temperature	-25...+70 °C
Product Enclosure Rating (Cubicle mounted) (Through-panel mounted)	IP20 - remainder of surfaces (Europe) UL (c-UL) Open Type (North America/Canada) IP20 UL (c-UL) Open Type (North America/Canada) IP20 UL (c-UL) Open Type (North America/Canada)
Altitude	1000 m ASL. Derate output by 1 % per 100 m to a maximum of 2000 m
Operating Humidity	Maximum 85 % relative humidity at 40 °C non-condensing
Atmosphere	Non-flammable, non-corrosive and dust free
Climatic Conditions	Class 3k3, as defined by EN60721-3-3
Chemically Active Substances	For the standard product, compliance with EN60271-3-3 is: <ul style="list-style-type: none"> • Both classes 3C3 and 3C4 for Hydrogen Sulphide gas (H₂S) at a concentration of 25 ppm for 1200 hours • Both classes 3C1 (rural) and 3C2 (urban) for all 9 defined substances as defined in table 4
Operating Vibration	Test Fc of EN60068-2-6 10 Hz<=f<=57 Hz sinusoidal 0.075 mm amplitude 57 Hz<=f<=150 Hz sinusoidal 1 g 10 sweep cycles per axis on each of three mutually perpendicular axis

Standards and Conformance

Overvoltage Category	Overvoltage category III (numeral defining an impulse withstand level)
Pollution Degree	Pollution degree II (non-conductive pollution, except for temporary condensation) for control electronics Pollution Degree III (dirty air rating) for through-panel mounted parts
North America/Canada	Complies with the requirements of UL508C and CSA22.2 #14 as an open-type drive
Europe	This product conforms with the Low Voltage Directive 2006/95/EC
EMC Compatibility	CE Marked in accordance with 2004/108/EC (EMC Directive)
RoHS Compliance	This product complies with RoHS substance restrictions in accordance with EC Directive 2011/65/EU

Dimensions

Panel Mounting

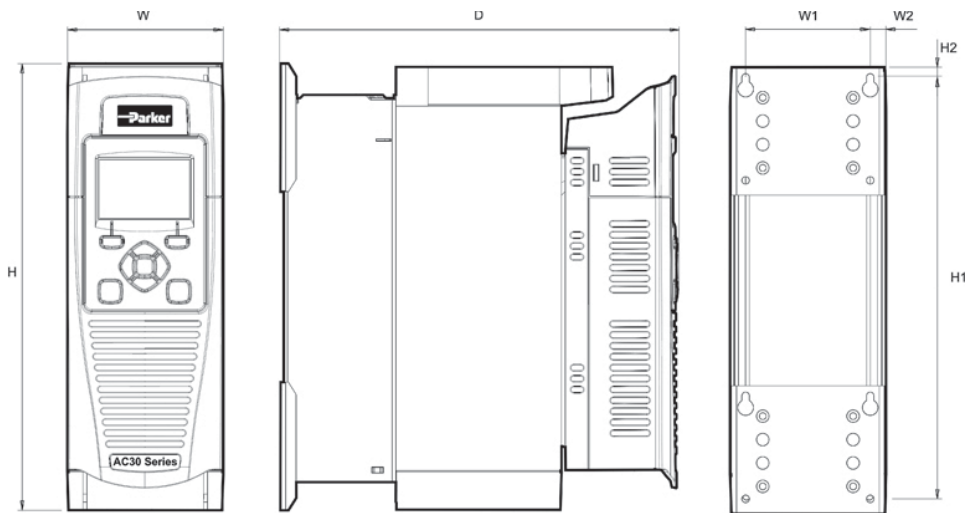

Dimensions [mm]

Model	Max. Weight [kg]	H	H1	H2	W	W1	W2	D	Fixings
Frame D	4.5	286.0	270.0	6.5	100.0	80.0	10.0	255.0	Slot 4.5 mm wide. Use M4 fixings
Frame E	6.8	333.0	320.0	6.5	125.0	100.0	12.5	255.0	
Frame F	10.0	383.0	370.0	6.5	150.0	125.0	12.5	255.0	
Frame G	22.3	480.0	465.0	7.25	220	190.0	13.0	287.0	Slot 5.0 mm wide. Use M5 fixings
Frame H	TBA	670.0	650.0	10.0	260.0	220.0	20.0	331.0	

Through Panel Mounting

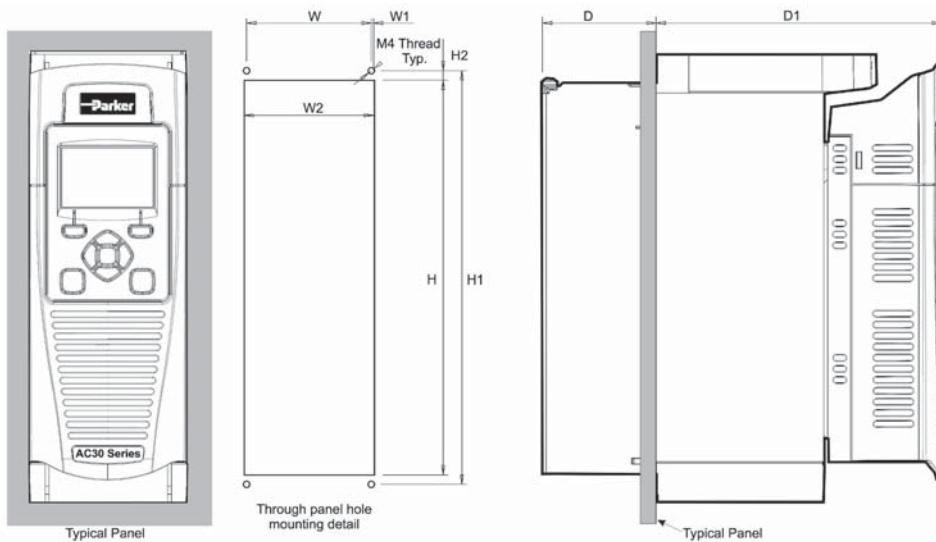

Dimensions [mm]

Model	H	H1	H2	W	W1	W2	D	D1	Fixings
Frame D	250	262	6	79	1.5	82	72	181	Use M4 fixings
Frame E	297	309	6	104	1	102	72	181	
Frame F	347	359	6	129	1	127	72	181	
Frame G	440	455.8	7.9	195.8	0.4	195	95	190	Use M5 fixings
Frame H	617	641	12	227	4.5	218	99	211	Use M6 Fixings

Connections

Power connections

Term.	Description
DB+	Dynamic Brake Resistor
DB-	Dynamic Brake Resistor
DC+	DC Link Bus +Ve
DC-	DC Link Bus -Ve
L1	L1 AC Input Supply
L2	L2 AC Input Supply
L3	L3 AC input Supply
M1	Motor Output 1/U
M2	Motor Output 2/V
M3	Motor Output 3/W

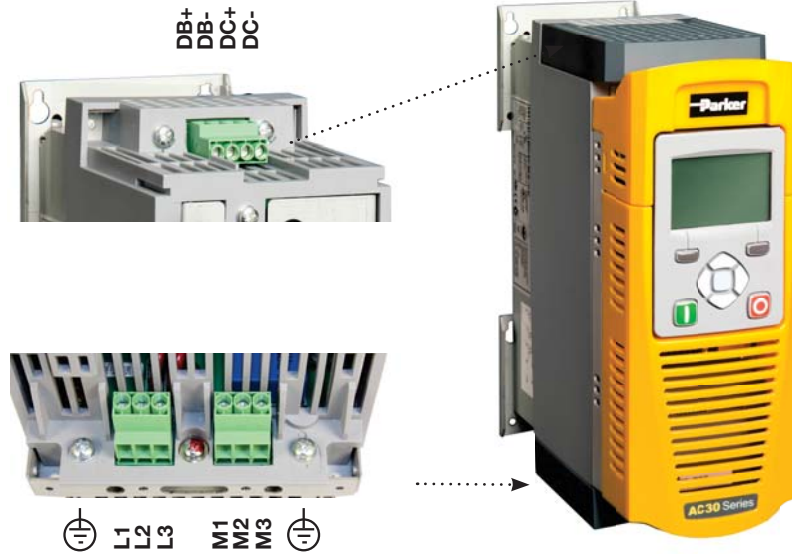

Safe Torque Off (STO)

The AC30 series features Safe Torque Off functionality as standard, offering users protection against unexpected motor start-up in accordance with EN13849-1 at PLe Cat 3 or SIL 3 to EN61800-5-2.

The STO functionality helps protect personnel and machinery by preventing the drive from restarting automatically. It disables the drive pulses and inhibits the power supply to the motor, so that the drive cannot generate any potentially hazardous movement. The state is monitored internally within the drive.

Term.	Label	Description
X10/01	STO A Input	STO Channel A input signal
X10/02	STO Common	Return signals for STO A and STO B
X10/03	STO B Input	STO Channel B input signal
X10/04	STO Common	Return signals for STO A and STO B
X10/05	STATUS A	STO Status Indication
X10/06	STATUS B	STO Status Indication

The example wiring diagram shows the minimum connections required to implement STO with the AC30 series AC drives.

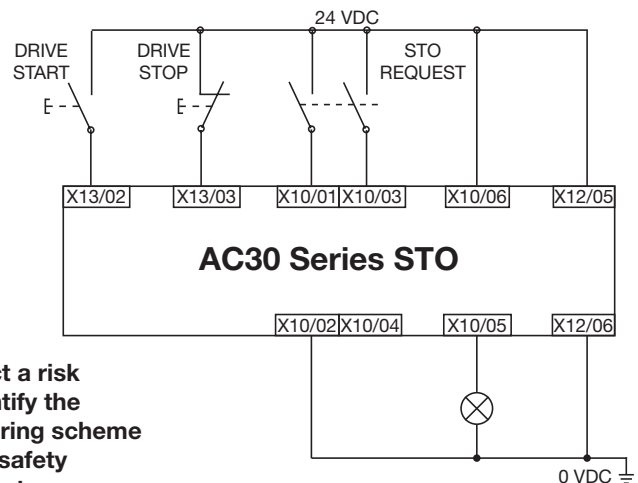

Users must conduct a risk assessment to identify the appropriate STO wiring scheme and ensure that all safety requirements are met.



It is the user's responsibility to ensure the safe and correct use of the STO function of the AC30 Series. User's should read and fully understand chapter 6 (Safe Torque Off) of the product user manual. Manual No. HA501718U001

Control wiring connections

Term.	Label
X10/01	STO A Input
X10/02	STO Common Return
X10/03	STO B Input
X10/04	STO Common Return
X10/05	STO Status A
X10/06	STO Status B
X11/01	ANIN 01 Analogue Input (± 10 V, 0-10 V, 0-20 mA, 4-20 mA)
X11/02	ANIN 02 Analogue Input (± 10 V, 0-10 V)
X11/03	ANOUT 01 Analogue Output (± 10 V, 0-10 V)
X11/04	ANOUT 02 Analogue Output (0-10 V, 0-20 mA, 4-20 mA)
X11/05	+10 V Reference
X11/06	-10 V Reference
X12/01	DIGIN04 / DIGOUT 01 Digital In/Out
X12/02	DIGIN05 / DIGOUT 02 Digital In/Out
X12/03	DIGIN06 / DIGOUT 03 Digital In/Out
X12/04	DIGIN07 / DIGOUT 04 Digital In/Out
X12/05	User +24 V Output
X12/06	0 V Common

Term.	Label
X13/01	0V Common
X13/02	DIGIN 1 Digital Input
X13/03	DIGIN 2 Digital Input
X13/04	DIGIN 3 Digital Input
X13/05	+24 V Auxiliary Input
X13/06	0 V Auxiliary Input
X14/01	Relay Output 01 (Contact A)
X14/02	Relay Output 01 (Contact B)
X14/03	Relay Output 02 (Contact A)
X14/04	Relay Output 02 (Contact B)

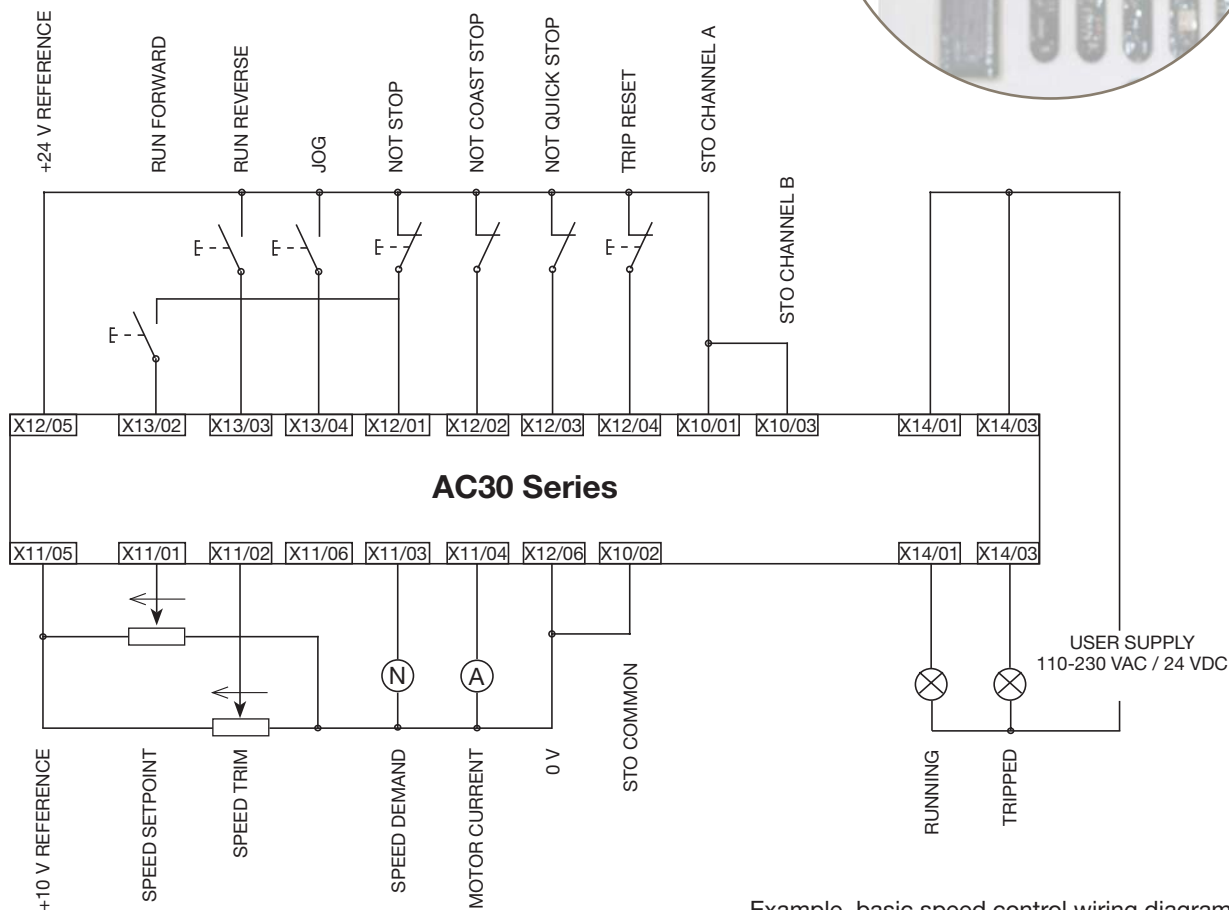
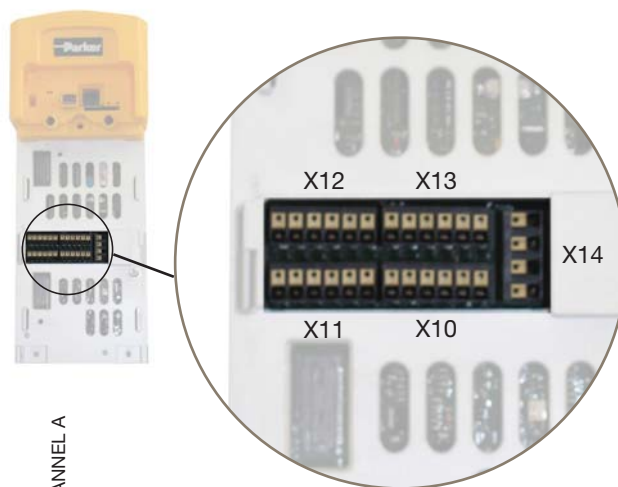

Example, basic speed control wiring diagram

Accessories and Options

Operator Keypad

Order Code	Description
7001-00-00	IP54 Graphical keypad
7001-01-00	Keypad blanking cover
LA501991U300	Keypad remote mounting kit (3 m cable and screws)

Description:

The backlit LCD graphical keypad can be either mounted locally on the drive or remotely with the use of a remote mounting kit. The keypad has 3 pass code protected user access levels which allows operators, technicians, or engineers to gain access to the relevant level of drive information.

The keypad makes use of a softkey menu system and can be used to set-up and commission the drive, change parameter settings, monitor running status or diagnose warning or alarm conditions.

The keypad can display information in one of the following languages. The display is also capable of displaying a user defined language set as well as a customised set of units.

- English
- German
- Spanish
- French
- Italian
- Customised



7001-00-00



7001-01-00

Data Storage and Cables

Order Code	Description
IF501990	SD card 2GB
CM501989U010	Ethernet cable 1 m
CM501989U011	Ethernet cable 3 m
CM501989U012	Ethernet cable 5 m



IF501990

Mounting and Filter Kits

Order Code	Description
BO501911U001	Frame D through panel mounting gasket
BO501911U002	Frame E through panel mounting gasket
BO501911U003	Frame F through panel mounting gasket
BO501911U004	Frame G through panel mounting gasket
BO501911U005	Frame H through panel mounting gasket
LA501935U001	Frame D C2 environment filter kit
LA501935U002	Frame E C2 environment filter kit
LA501935U003	Frame F C2 environment filter kit
LA501935U004	Frame G C2 environment filter kit
LA501935U005	Frame H C2 environment filter kit



LA501935U001

The environment filter kit consists of a motor cable ferrite core and screening brackets and is required to comply with the requirements of the EMC directive for a C2 environment.

Communication Interfaces

7003-PB-00	PROFIBUS DP-V1 communication interface
Supported Protocols	PROFIBUS-DP; Demand data and Data exchange
Communication Speed	Up to 12 Mbits/s; automatically detected
Max. number of devices	32 per segment, 126 total
Supported Messages	Up to 152 bytes cyclic I/O, 68 bytes class 1 and 2 acyclic data, 152 bytes configuration data. GSD file provided



7003-DN-00	DeviceNet communication interface
Supported Protocols	DeviceNet protocol (slave)
Communication Speed	125, 250, 500 kbits/s or automatically detected
Max. number of devices	64
Supported Messages	Bit strobed I/O, Polled I/O, Cyclic I/O, Change of state, Explicit messaging



7003-CB-00	CANopen communication interface
Profile	DS301 V4.02
Communication Speed	10 k, 20 k, 50 k, 125 k, 250 k, 500 k, 1 Mbits/s or automatically detected
Max. number of devices	127
Supported Messages	SDO, PDO, NMT, SYNC



7003-PN-00	PROFINET I/O communication interface
Supported Protocols	PROFINET I/O Real-Time (RT) Protocol
Communication Speed	100 Mbits/s full duplex
Max. number of devices	Virtually unlimited
Supported Messages	Up to 256 bytes of cyclic I/O in data in each direction



7003-IP-00	Ethernet IP communication interface
Supported Protocols	Ethernet IP
Communication Speed	10/100 Mbits/s full/half duplex
Max. number of devices	Virtually unlimited
Supported Messages	Up to 256 bytes of consumed data and 256 bytes of produced data, CIP parameter object support, Explicit messaging



7003-RS-00	RS485 / Modbus RTU communication interface
Supported Protocols	Modbus RTU
Communication Speed	1200 to 115200 bits/s
Max. number of devices	247
Supported Messages	Up to 256 bytes of cyclic I/O data in each direction



Communication Interfaces

7003-BN-00	BACnet MSTP communication interface
Supported Protocols	BACnet/MSTP
Communication Speed	up to 76.8 kbits/s
Max. number of devices	255
Supported Messages	Real time synchronisation according to DM-T S-B, COV notifications and Alarm/Event functionality



7003-BI-00	BACnet/IP communication interface
Supported Protocols	BACnet/IP
Communication Speed	100 Mbits/s
Max. number of devices	255
Supported Messages	Real time synchronisation according to DM-T S-B, COV notifications and Alarm/Event functionality



7003-CN-00	ControlNet communication interface
Supported Protocols	ControlNet
Communication Speed	5 Mbits/s
Max. number of devices	99
Supported Messages	Polled I/O



7003-EC-00	EtherCAT communication interface
Supported Protocols	CANopen over EtherCAT (CoE) DS301 compliant
Communication Speed	100 Mbits/s
Max. number of devices	65534
Supported Messages	SDO, PDO, NMT, SYNC



7003-IM-00	Ethernet TCP communication interface
Supported Protocols	Modbus/TCP
Communication Speed	10/100 Mbits/s
Max. number of devices	Virtually unlimited
Supported Messages	CIP parameter object support, Explicit messaging



Input and Output Cards

7004-01-00 - General Purpose I/O Module

Digital Inputs & Outputs	4x Digital inputs or outputs
Analogue Inputs/Outputs	3x Analogue inputs (± 10 V)
Relay Outputs	2x Volt-free relay outputs (230 VAC)
Motor Thermistor Inputs	1x Motor thermistor input
Real time Clock	Included

Description:

The general purpose I/O (GPIO) option module can be fitted to all AC30V series drives in the upper I/O option module slot. The modules are field-fittable and offer users the opportunity to expand the drives standard I/O capability, allowing more complex motor control solutions to be implemented.



Connection Details:

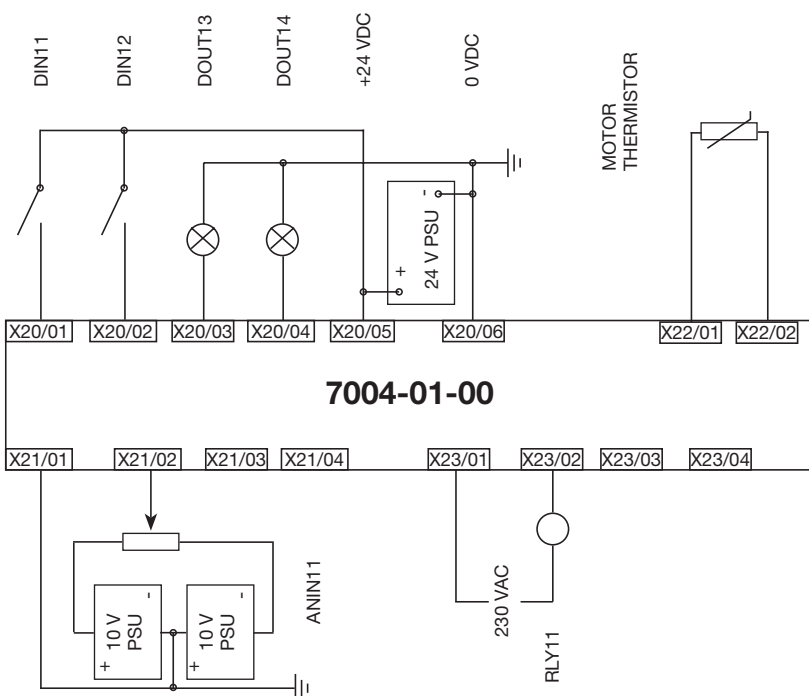

Example connection details for 7004-01-00 GPIO module

Terminal	Label
X20/01	DIN11/DOUT11
X20/02	DIN12/DOUT12
X20/03	DIN13/DOUT13
X20/04	DIN14/DOUT14
X20/05	+24 VDC
X20/06	0 VDC COMMON
X21/01	REFERENCE
X21/02	ANIN11
X21/03	REFERENCE
X21/04	ANIN12
X22/01	MOTOR THERMISTOR
X22/02	MOTOR THERMISTOR
X23/01	RLY11
X23/02	RLY11
X23/04	RLY12
X23/04	RLY12

7004-02-00 - Motor Thermistor Input Module

Motor Thermistor Inputs	1x Motor thermistor input
Thermistor Compatibility	PTC, NTC, KTY
Thermistor Resistance Range	0...4.5 k Ω

Description:

The Isolated motor thermistor input module provides a means of monitoring motor temperature in order to protect the motor from a potentially damaging high temperature.

By default the drive will trip if the motor exceeds a user-defined temperature threshold thereby preventing motor temperature from rising further.



7004-03-00 - Real Time Clock and Motor Thermistor Input Module

Motor Thermistor Inputs	1x Motor thermistor input
Thermistor Compatibility	PTC, NTC, KTY
Thermistor Resistance Range	0...4.5 kΩ
Time Format	Seconds
Accuracy (drive powered)	±1 minute / month (RTC trim=0)
Accuracy (drive unpowered)	±5 minutes / month (RTC trim=0)
Battery Backup Duration	6 Months



Description:

A real-time clock (RTC) is provided for the user to program the drive to perform functions at specified times. The RTC is battery-backed, so continues to run when the drive is unpowered. The battery recharges when the drive is powered.

An isolated motor thermistor input is also included in the 7004-03-00 module.

7004-04-00 - Pulse Encoder Feedback Module

Maximum Input Frequency	250 Hz per channel
Supply Voltage Output	5 V, 12 V, 15 V, 24 V
Input Format	Quadrature, or Clock (inputs A & /A) and Direction (input B & /B)
Motor Thermistor Details	As 7004-02-00



Description:

The pulse encoder feedback module allows an incremental encoder to be connected to the AC30 allowing users to take full advantage of the enhanced torque control and speed regulation functionality of the drive. In addition, the 7004-04-00 is also equipped with a single motor thermistor input.

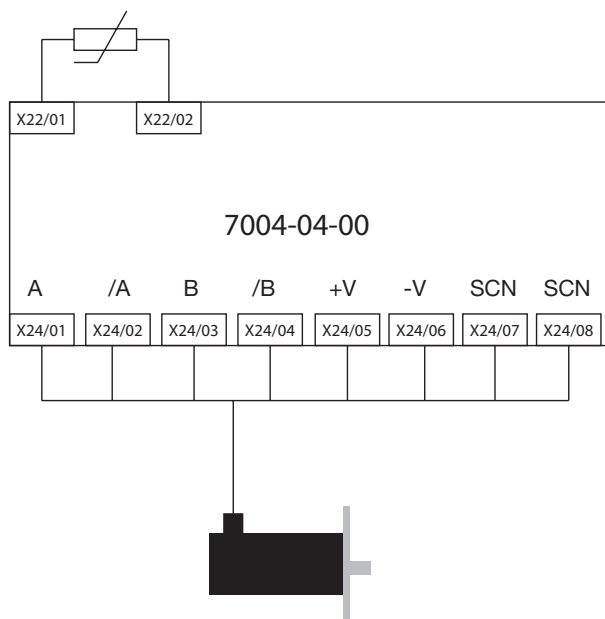

Terminal	Description
X24/01	Channel A
X24/02	Channel /A
X24/03	Channel B
X24/04	Channel /B
X24/05	Supply positive
X24/06	Supply negative
X24/07	Cable screen
X24/08	Cable screen
X22/01	Motor thermistor
X22/02	Motor thermistor

Anciliary Parts

Output Chokes

To reduce capacitive currents and prevent nuisance tripping in installations with longer cable runs, a choke may be fitted to the drives output in series with the motor.

Order Code	Motor Power Normal Duty [kW]	Choke Inductance [mH]	Current [A _{rms}]
CO55931	1.1	2	7.5
	1.5		
	2.2		
	3.0		
CO57283	4.0	0.9	22
	5.5		
	7.5		
CO57284	11	0.45	33
	15		
CO57285	18	0.3	44
CO55193	22	50	70
	30		
CO55253	37	50	99
	45		
CO57960	55	50	243
CO387866	75	50	360



EMC Filters

A range of custom designed optional EMC (Electromagnetic Compatibility) filters are available for use with Parker's range of drive products. They are used to help achieve conformance with the EMC directive BS EN 61800-3:2004- "Adjustable speed electrical power drive systems Part 3". These external filters offer C2 compliance to 25m and C1 compliance to 10m.

Order Code	Motor Power Normal Duty [kW]	Frame Size
CO501894	1.1	D
	1.5	D
	2.2	D
	3.0	D
	4.0	D
	5.5	D
	7.5	E
CO501895	11	E
	15	F
	18	F
CO465188U070	22	G
	30	G
Contact your local sales office	37	G
	45	H
	55	H
	75	H



Braking Resistors

These resistor sets are designed for stopping the system at rated power. Rated for 10 seconds in a 100 seconds duty cycle. They are metal-clad resistors and should be mounted on a heatsink (back panel) and covered to prevent injury from burning.



Brake resistor selection

Brake resistor assemblies must be rated to absorb both peak braking power during deceleration and the average power over the complete cycle.

$$\text{Peak braking power} = \frac{0.0055J \times (n_1^2 - n_2^2)}{t_b} \text{ (W)}$$

$$\text{Average braking power } P_{av} = \frac{P_{pk} \times t_b}{t_c}$$

J: total inertia [kgm²]
 n₁: initial speed [min⁻¹]
 n₂: final speed [min⁻¹]
 t_b: braking time [s]
 t_c: cycle time [s]

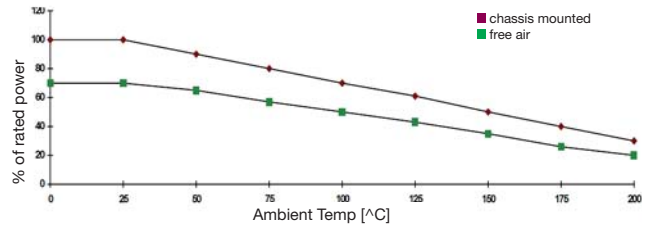

Resistors above 500 W

Resistors above 500 W are available upon request :

- IP20 protection up to 3 kW
- IP13 protection between 4.2 and 9.8 kW

Model	Impedance [Ω]	Nom. Power [W]	Dimensions [mm]							
			L1	L2	L3	W	H	D	a	b
CZ467715	500	60	100	87	60	22	41	4.3	10	12
CZ467714	200	100	165	152	125	22	41	4.3	10	12
CZ389853	100	100	165	152	125	22	41	4.3	10	12
CZ467717	100	200	165	146	125	30	60	4.3	13	17
CZ463068	56	200	165	146	125	30	60	4.3	13	17
CZ388397	56	200	165	146	125	30	60	4.3	13	17
CZ388396	36	500	335	316	295	30	60	4.3	13	17
CZ467716	28 x 2	500	335	316	295	30	60	4.3	13	17

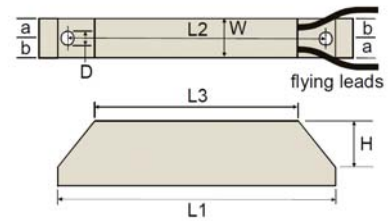

Overload 5 s: 500 %
 Overload 3 s : 833 %
 Overload 1 s: 2500 %

Parker Drive Quicktool (PDQ) Software

Description

PDQ is a simple software tool for installing, programming and monitoring applications on the AC30 series variable speed drive.

Communication between the drive and PC is via the in-built Ethernet port at the top of of the drive and the software automatically detects all AC30s connected to the Ethernet network.

Once the drive is selected, a simple wizard guides the user through the installation process. Starting with the required application the user is asked to choose their motor data from a motor database or enter their own specific data, to configure the I/O and communications and finally commission the drive. The drive parameters can then be monitored, charted and adjusted.

The drive also supports its own webserver providing access to all drive parameters for quick and easy changes.

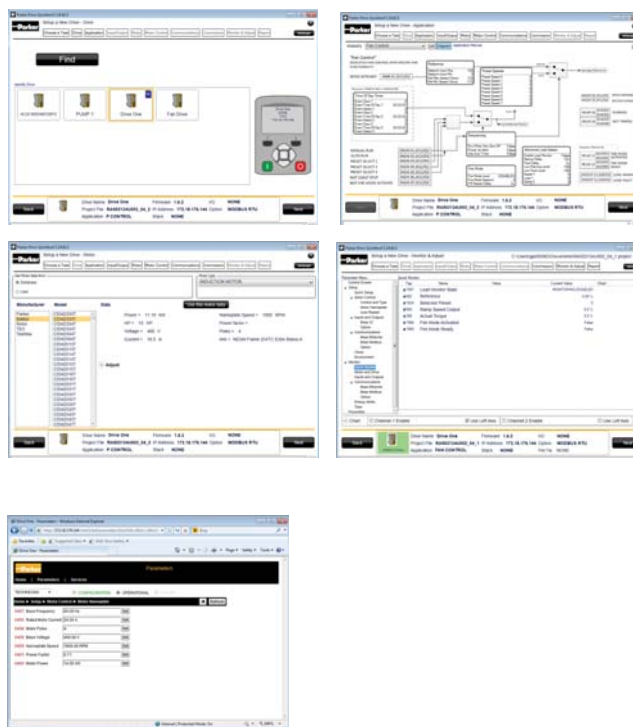

Parker Drive Quicktool is shipped with every drive and can also be downloaded for free from the Parker website. www.parker.com/ssd/pdq

Parker Drive Developer (PDD) Software

Description

PDD is a fully featured PLC programming tool for the AC30 series variable speed drive, supporting all IEC-61131 languages including ladder logic, structured text and function block diagrams.

It provides access to all drive parameters and enables the user to create powerful AC30 drive solutions. It's also possible to create custom parameters and menus so the user can describe the setup and status of the drive in the context of their own application.

To help start the development process Parker provides pre-installed libraries with the following functionality:

- Basic Speed Control
- Fan and Pump Control
- Winder Blocks
- Hydraulic Control
- Cascaded Pump Control

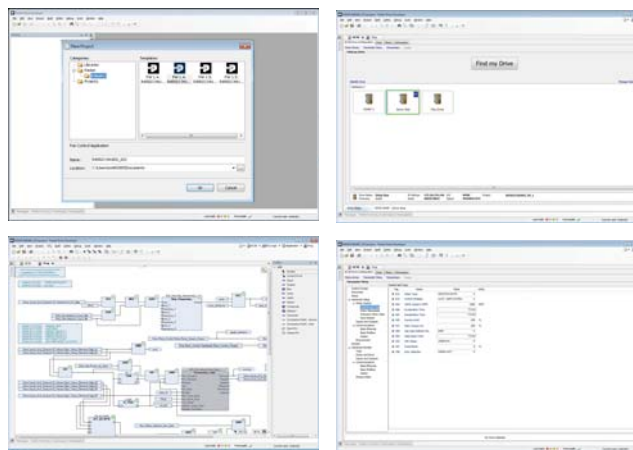

Order Code

	1	2	3	4	5	6	7	8
Order example	31V	4	D	0004	B	F	T10	M00

1 Device Family	31V AC30 Series complete drive
	710 Power stack only (no control module)
2 Voltage	4 400 V nominal
3 Frame Size and Current Rating	(normal / heavy duty)
	D0004 1.1 kW / 0.75 kW
	D0005 1.5 kW / 1.1 kW
	D0006 2.2 kW / 1.5 kW
	D0008 3 kW / 2.2 kW
	D0010 4 kW / 3 kW
	D0012 5.5 kW / 4 kW
	E0016 7.5 kW / 5.5 kW
	E0023 11 kW / 7.5 kW
	F0032 15 kW / 11 kW
	F0038 18.5 kW / 15 kW
	G0045 22 kW / 18.5 kW
	G0060 30 kW / 22 kW
	G0073 37 kW / 30 kW
	H0087 45 kW / 37 kW
	H0105 55 kW / 45 kW
	H0145 75 kW / 55 kW

4 Brake Switch	B Brake switch fitted
	N No brake switch option ⁽¹⁾
5 EMC Filter ⁽²⁾	N No filter fitted
	E Category C3 filter fitted
	F Category C2 filter fitted
6 Graphical Keypad	0 No keypad fitted
	1 Blanking cover fitted
	2 Graphical keypad fitted
7 Environmental Coating ⁽³⁾	S Standard 3C3 coating
	E Enhanced coating
8 Special Options	0000 No special options

⁽¹⁾ Available for frame H only

⁽²⁾ The choice of filter should be determined by the environment in which the drive will be installed as defined in IEC/EN61800-3 C2 = domestic & commercial, C3 = industrial

⁽³⁾ AC30 is conformally coated as standard for use in environments class 3C3 and 3C4 for Hydrogen Sulphide gas. It is also compliant to both classes 3C1 (rural) and 3C2 (urban) for all nine substances defined in table 4 in EN60271-3-3

Versatile Control Module

It is possible to order the AC30 Series as a separate power stack and versatile control module. This is useful for distributor or MRO spare part stocking.



Versatile Control Module - 30V-...



Order code 710... Power Stack Only

Order Code	Description
30V-2S-0000	Control module with graphical keypad and standard coating
30V-1S-0000	Control module with blanking cover and standard coating
30V-0S-0000	Control module with standard coating and no graphical keypad
30V-2E-0000	Control module with graphical keypad and enhanced coating
30V-1E-0000	Control module with blanking cover and enhanced coating
30V-0E-0000	Control module with enhanced coating and no graphical keypad

Accessories

Graphical Keypad

Order Code	Description
7001-00-00	Graphical keypad for local or remote mounting
7001-01-00	Keypad blanking cover
LA501991U300	Keypad remote mounting kit (3 m cable and screws)

I/O Options

Order Code	Description
7004-01-00	General purpose I/O module
7004-02-00	Motor thermistor input module
7004-03-00	Real time clock and motor thermistor input module
7004-04-00	Pulse encoder feedback card

Communication Interfaces

Order Code	Description
7003-PB-00	Profibus DPV1
7003-PN-00	Profinet IO
7003-DN-00	DeviceNet
7003-CN-00	ControlNet
7003-CB-00	CANopen
7003-IP-00	Ethernet IP
7003-IM-00	Ethernet TCP
7003-EC-00	EtherCAT
7003-BI-00	BACnet IP
7003-BN-00	BACnet MSTP
7003-RS-00	RS485/Modbus RTU

High Performance Modular Systems Drive - AC890 Series

Description

The AC890 is a compact, high performance AC drive engineered to control speed and position of open- and closed-loop, single- or multi-motor AC induction or brushless servo motor applications.

Available as a standalone drive with AC input and direct connection to a motor, or as a common bus drive supplied via the DC bus connections, AC890 can be configured to provide control in four different modes of operation.

- **Open-loop (volts / frequency) control**
deal for simple, single or multi-motor speed control.
- **Sensorless vector control**
A high performance sensorless vector algorithm delivering a combination of high torque and close speed regulation without the need for a speed sensor.
- **Closed-loop vector control**
Full closed-loop flux vector control can be achieved by simply adding an encoder feedback option module. This provides 100 % continuous full load standstill torque and a highly dynamic speed loop to suit even the most demanding applications.
- **4 Quadrant Active Front End (AFE)**
AC890 can be used to feed regenerative energy back on to the mains supply in line with unity power factor and in line with international harmonic limits.



Technical Specification - overview

Power Supply	890CS: 208-500 VAC $\pm 10\%$ 890CD: 320/560-705 VDC 890SD: 380-500 VAC $\pm 10\%$ Frames E/F/G/H/J: 380-460 VAC $\pm 10\%$
Environment	0 ... 45 °C (derate by 2 %/ °C up to 50 °C maximum) Max. 1000 m ASL (derate by 1 %/100 m to 2000 m)
Protection	IP20 (Frames G/H/J: IP00)
Humidity	Maximum 85 % Non-Condensing
Analogue Inputs	4; Configurable 2 x 0-10 V, ± 10 V, 0-20 mA, 4-20 mA and 2 x 0-10 V, ± 10 V
Analogue Outputs	2; Configurable 0-10 V, +/- 10 V
Digital Inputs	7; Configurable 24 VDC
Digital Output	2; Configurable 24 VDC
Digital Relay Output	1; Configurable
Communications Options	EtherNet/IP, Modbus/TCP, CANopen, PROFIBUS, PROFINET, DeviceNet, ControlNet, FireWire, EtherCAT, Peer to peer, RS458/Modbus
Axis Synchronisation	Internally via Firewire
Registration Control Options	Mark Registration (EnDat 2.1 Encoder)

Features

Range of feedback options

- Incremental encoder
- EnDat® 2.1 (SinCos) encoder
- Resolver

Open FireWire IEEE 1394 Process Port

- 125 µs cycle time
- Real-time synchronization between drives



Open communication



Ultra-fast control loops

- Torque loop: 62.5 µs
- Speed loop: 62.5 µs
- Position loop: 62.5 µs

* stand alone version shown



Benefits

► Integrated safety functionality

The integrated Safe Torque Off (STO) functionality offers protection against unexpected motor start-up, in accordance to EN 13849-1 PL-e, or SIL 3 to EN61800-5-2.

► Minimal delay between fieldbus setpoints and the control loops

Designed to integrate in existing automation systems, the AC890 features high performance ports linked directly to the fast control loops of the drive.

Minimum delay exists between your digital setpoint sent through a fieldbus and the control loops.

► Replacement of analogue solutions

Your existing analogue setpoint-based solutions can be replaced by a digital fieldbus-based solution with minimal bandwidth loss.

► Flexible feedback options

The AC890 offers system designers complete flexibility in their choice of feedback technology to best suit the needs of their application.

► Open standards for protection of investment

The AC890 has been specifically designed to integrate seamlessly into your automation network.

To connect to your PLC or fieldbus network you can simply choose from the wide range of communication technology boxes.

Serves the most demanding applications

Taking advantage of leading edge control algorithms running on a fast 150 MHz microprocessor, the AC890 drive can achieve very high-bandwidth control loops. This allows you to use the drive for the most demanding industrial applications e.g. printing, cut-to-length, rotary shear, converting and slitting.

The Ability to Perform

AC890 is available in two different performance levels with increasing functionality in the form of application specific function blocks.

This allows you to match the performance of your drive to the specific needs of your application.

Advanced Performance

- Motion control with position control,
- Motion control function blocks: incremental move, absolute move, move home
- Section control function blocks: Line drive master ramp, winder blocks (speed and current winder), PID process, sequencer.

High Performance

- All advanced features plus: Library of pre-engineered application specific LINK VM function blocks such as: Shaftless printing, cut-to-length, advanced winding, advanced traversing.

Space saving compact footprint thanks to modular design concept

Stand Alone version



The Complete Drive

The AC890SD series Stand Alone drive provides a complete AC input to AC motor output, with power input and output terminals.

Other characteristics of the AC890SD include:

- Power output up to 315 kW
- 208...500 VAC input supply
- Access to all feedback and networking options
- Built-in dynamic brake switch provisions to add external braking resistor
- 24 VDC control board supply for programming without power
- Torque and speed outputs
- USB programming port

Common Bus version



Common Bus Drive

The AC890 is also available in a common bus platform, where individual motor output drives are easily connected to a common bus supply.

Characteristics of the common bus drive (AC890CD):

- Power output to 90 kW in 5 frame sizes
- Power Supply: 320...705 VDC
- Access to all feedback and networking options
- 24 VDC control board supply for programming without power
- Torque and speed analogue outputs
- USB programming port

Characteristics of the common bus supply module (AC890CS):

- Power output 7.5...110 kW
- Power Supply: 208...500 VAC
- Built-in dynamic braking unit (external braking resistor required)
- Operator display for diagnostics
- Up to 162 A output per module

Removable terminal block connections for easier installation and maintenance



Reduced dimensions, compact footprint

The AC890 has been designed to be compact and require the minimum possible cabinet space. Boasting the latest innovations in semiconductor cooling the AC890 is a class leader in terms of its size.

The control terminals are pluggable, simplifying connection to the drive during installation and allowing a fast swap-out for maintenance purposes.

The Common DC bus also helps to keep the overall size of the system to a minimum. Simply open the bus terminal cover, connect the busbars and close.

Fast connection of the common DC bus



Alternative Input Power Configurations

The modular design of AC890 makes it easy to connect parallel input modules and multi-phase configurations. By using 12- or 18-pulse configurations, harmful line harmonics can be greatly reduced. For the ultimate in harmonic abatement, an active front end (AFE) may be selected.

4 Quadrant active front-end power supply with regeneration to the supply network

In systems where frequent braking and starting is common in everyday operation it is possible to use AC890 to recover the braking energy of a load moving faster than the designated motor speed (an overhauling load) and return it to the mains supply.

Typically applications that could benefit from a regenerative system include feed conveyors, cranes, winches or process machinery.

Additional components are required to implement an active front-end system.

Benefits of an Active Front-End Regenerative System

- Fully Bidirectionnel power flow
- 150 % overload for 60 s
- Sinusoidal input current
- Harmonic levels in line with international requirements

Common Bus Adaptor

For higher power systems it is possible to use a larger standalone AC890 Active Front End module. In this case rows of AC890CD drives can be connected via their DC bus connections to the AFE using a Common Bus Adaptor (AC890CA)

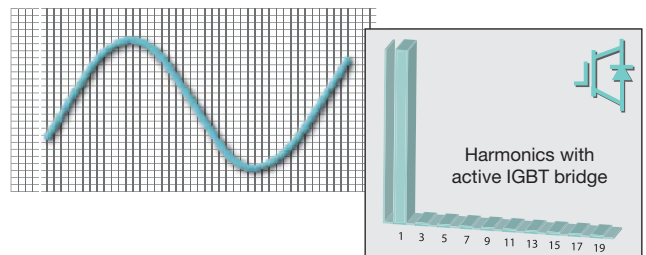
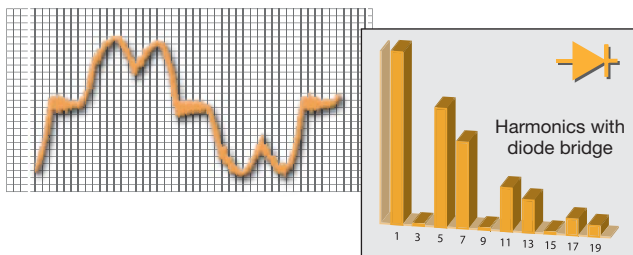
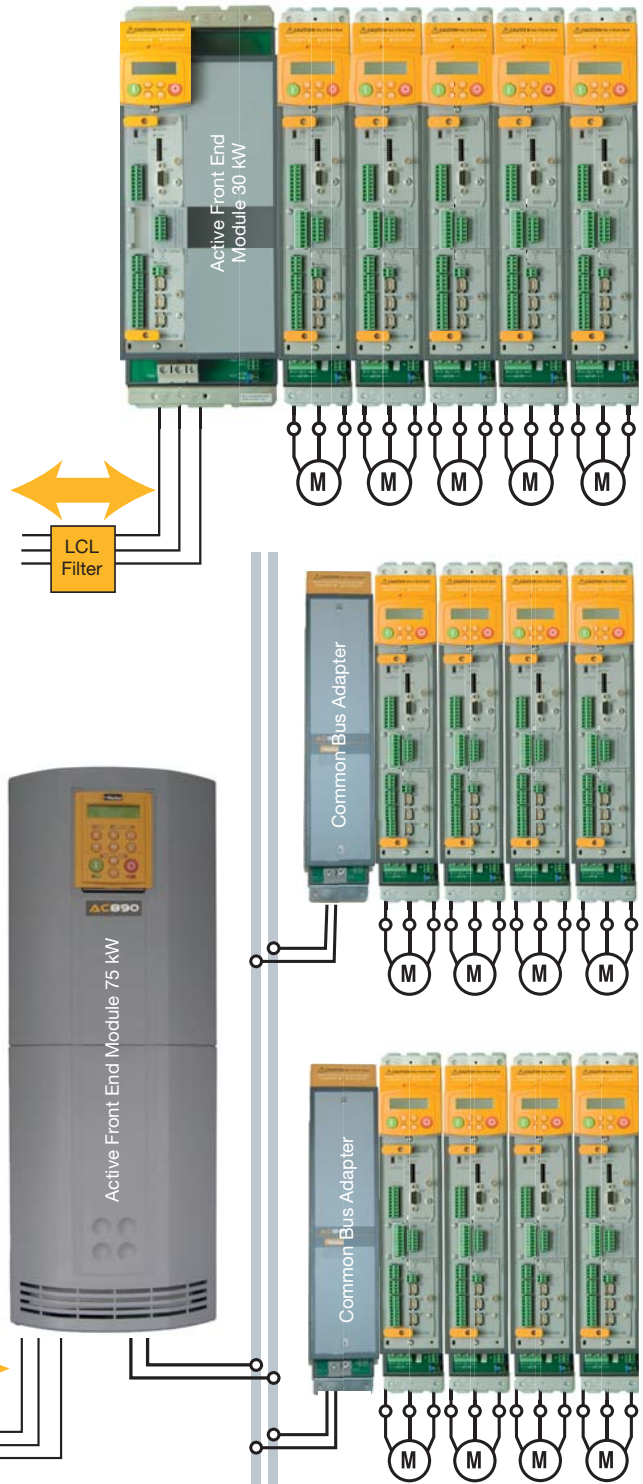

For alternative input power configurations, please contact your local sales office

AC890CS Common DC Bus Power Supply

7.5 kW - 110 kW

Description

The AC890CS power supply module is able to provide dual output voltages to power one or more common bus AC890CD, or stand-alone AC890SD drives connected in a common DC bus configuration. This modularity delivers significant space saving in the electrical enclosure.

Features

- 208 – 500 VAC supply voltage
- 7.5 kW – 110 kW Power output
- Built-in dynamic braking unit
- Dual DC bus power output terminals
- Operator display for diagnostics

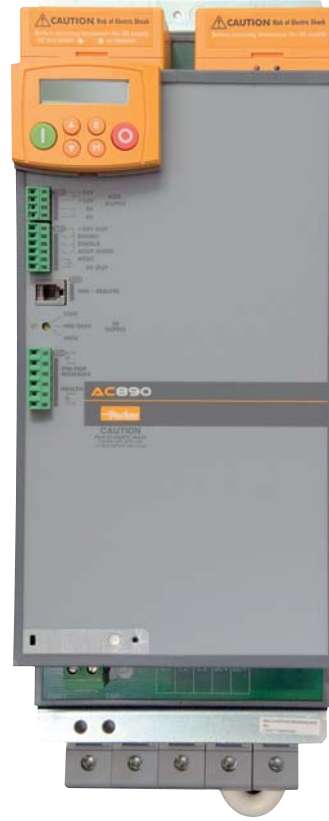

Electrical Characteristics

Order code	Power [kW]	Input voltage [VAC]	Frame	AC input current [A]	DC output current [A]	
890CS-532320B0-000-U	7.5	230	B	32	40	
	15	400 / 460				
	18	500				
890CS-532540B0-000-U	15	230		D	54	65
	30	400 / 460				
	37	500				
890CS-533108D0-000-U	30	230	D		108	135
	60	400 / 460				
	75	500				
890CS-533162D0-000-U	45	230		D	162	200
	90	400 / 460				
	110	500				

Note: For increased power, additional units can be connected in parallel. For further details, contact our technical support department.

AC890CD Series Common DC Bus Variable Speed Drive

0.55 kW - 90 kW

Description

Available in 3 power supply versions, the AC890CD common DC bus variable speed drive is designed to be fed via its common DC bus in conjunction with either an AC890CS power supply module or an AC890CA common bus adapter.

Features

- 320, 650, 705 V DC supply voltage
- Power output to 90 kW
- Suitable for use with all common AC890 Series feedback and communications options
- USB programming port



Electrical Characteristics

Order code	Power [kW]	Input voltage [VDC]	Frame	DC input current [A]	Output current [A]	
					Vector mode	Servo mode
890CD-231300B0-000-...	0.55	320	B	4.2	3	2.2
890CD-231550B0-000-...	1.1			7.6	5.5	4
890CD-231700B0-000-...	1.5			9.3	7	6
890CD-232110B0-000-...	2.2			15.2	11	8
890CD-232165B0-000-...	4			22.2	16.5	12
890CD-531200B0-000-...	0.55	560		2.9	2	1.5
890CD-531350B0-000-...	1.1			5	3.5	2.5
890CD-531450B0-000-...	1.5			6.6	4.5	3.5
890CD-531600B0-000-...	2.2			8.6	6	4
890CD-532100B0-000-...	4			14.1	10	6
890CD-532120B0-000-...	5.5			16.8	12	9
890CD-532160B0-000-...	7.5	22.2	16	12		
890CD-232240C0-000-...	5.5	320	C	31	24	24
890CD-232300C0-000-...	7.5			39	30	30
890CD-532240C...	11	560		33	24	20
890CD-532300C...	15			43	30	25
890CD-532390D0-000-...	18.5	560	D	44	39	35
890CD-532450D0-000-...	22			51	45	38
890CD-532590D0-000-...	30			66	59	50
890CD-432730E0-0...	37	560	E	82	73	73
890CD-432870E0-0...	45			100	87	87
890CD-532730E0-0...	37	705		66	67	67
890CD-532870E0-0...	45			80	79	79
890CD-433105F...	55	560	F	123	105	78
890CD-433145F...	75			166	145	110
890CD-433156F...	90			203	180	135
890CD-433180F...	90	203		180	135	
890CD-533105F...	55	705		98	100	74
890CD-533145F...	75			133	125	95
890CD-533156F...	90		162	156	117	

Note: For higher powers, refer to AC890SD series supplied from a DC bus.

AC890SD Series Standalone Variable Speed Drive

0.55 kW - 315 kW

Description

AC890SD standalone drives are independent modules with integrated three-phase supply inputs. With a wide range of sizes available, the AC890SD is suitable for every type of application from a small machine to a large industrial high power process line (eg. rolling mill). It is also ideally suited to sectional control such as that found in printing systems.

Features

- Directly supplied AC or DC common bus
- Built-in dynamic braking module
- Suitable for use with all common AC890 Series feedback and communications options
- USB programming port



Electrical Characteristics

Electrical Characteristics – 230V single phase drive

Order code	Power [kW]	Input voltage [VAC]	Frame	Input current [A]		Output current [A]	
				Vector mode	Servo mode	Vector mode	Servo mode
890SD-231300B0-B00-...	0.55	230	B	4.2	4.2	3	2.2
890SD-231550B0-B00-...	1.1			7.7	7.3	5.5	4
890SD-231700B0-B00-...	1.5			10.1	9.9	7	6
890SD-232110B0-B00-...	2.2			15.2	12.9	11	8
890SD-232165B0-B00-...	4			21.8	18.2	16.5	12
890SD-232240C0-B00-...	5.5			C	31	31	24
890SD-232300C0-B00-...	7.5		40		40	30	30

Note: Power ratings are given for 230 VAC

Permitted overload: 150 % for 60 s in vector mode - 200 % for 4 s in servo mode.

Electrical Characteristics – three phase drives

Order code	Power [kW]	Input voltage [VAC]	Frame	Input current [A]		Output current [A]	
				Vector mode	Servo mode	Vector mode	Servo mode
890SD-531200B0-B00-...	0.55	380-500	B	2.9	2.9	2	1.5
890SD-531350B0-B00-...	1.1			5	4.7	3.5	2.5
890SD-531450B0-B00-...	1.5			6.8	6.4	4.5	3.5
890SD-531600B0-B00-...	2.2			9	7.2	6	4
890SD-532100B0-B00-...	4			14	9.7	10	6
890SD-532120B0-B00-...	5.5			16.5	13.8	12	9
890SD-532160B0-B00-...	7.5			21.7	17.9	16	12
890SD-532240C0-B00-...	11	380-500	C	32	32	24	20
890SD-532300C0-B00-...	15			40	40	30	25
890SD-532390D0-B00-...	18.5	380-500	D	42	38	39	35
890SD-532450D0-B00-...	22			50	45	45	38
890SD-532590D0-B00-...	30			62	54	59	50
890SD-432730E0-0...	37	380-460	E	81	81	73	73
890SD-432870E0-0...	45			95	95	87	87
890SD-433105F...	55	380-460	F	114	114	105	78
890SD-433145F...	75			143	143	145	110
890SD-433156F...	90			164	164	180	135
890SD-433216G...	110	380-460	G	216	216*	216	153
890SD-433250G...	132			246	246	250	171
890SD-433316G...	160			305	305	316	224
890SD-433361G...	180			336	336	361	253
890SD-433375H...	200	380-460	H	367	367	375	268
890SD-433420H...	220			400	400	420	300
890SD-433480H...	250			466	466	480	336
890SD-433520H...	280			516	516	520	368
890SD-433590J...	315	380-460	J	576	576	590	411
890SD-532730E0-0...	37	380-500	E	69	69	67	67
890SD-532870E0-0...	45			82	82	79	79
890SD-533105F...	55	380-500	F	93	93	100	74
890SD-533145F...	75			118	118	125	95
890SD-533156F...	90			140	140	156	117

Permitted overload:

150 % for 60 s in vector mode

200 % for 4 s in servo mode (Frames B, C, D)

150 % for 60 s in servo mode (Frames E, F, G, H, J)

Electrical Characteristics

Operating Temperature	0 °C to +45 °C	
Storage Temperature	-25 °C to +55 °C	
Shipping Temperature	-25 °C to +70 °C	
Product Enclosure Rating	IP20 - UL (c-UL) Open Type (North America/Canada) Type 1 Suitable for cubicle mount only	
Cubicle Installation	The 890 must be installed to EN60204 Standard in the cubicle. For USA, the cubicle shall meet the requirements of UL50.	
Cubical Rating	Cubicle to provide the following attenuation to radiated emissions:	
	EMC Enclosure Standard	Attenuation to RF in spectrum 30...1000 MHz
	EN61800-3 Category C3	None
	EN61800-3 Category C1 Restricted Distribution EN61000-6-3	10 db
	EN61800-3 Category C1 Unrestricted Distribution EN61000-6-4	20 db
Humidity	Maximum 85 % relative humidity at 40 °C (104 °F) non-condensing	
Altitude	If greater than 1000 m above sea level, derate by 1 % per 100 m to a maximum of 2000 m	
Atmosphere	Non flammable, non corrosive and dust free	
Climatic Conditions	Class 3k3, as defined by EN50178	
Vibration	The product has been tested to the following specification: Test Fc of EN60068-2-6 10 Hz<=f<=57 Hz sinusoidal 0.075 mm amplitude 57 Hz<=f<=150 Hz sinusoidal 1 g 10 sweep cycles per axis on each of three mutually perpendicular axis	

Standards and Conformance

Pollution Degree	Pollution Degree II (non-conductive pollution, except for temporary condensation)
Europe	When fitted inside an enclosure, this product conforms with the Low Voltage Directive 2006/95/EC using EN50178 to show compliance.
North America / Canada	Complies with the requirements of UL508C as an open-type drive.
Conformal Coated Product	Conformal coating increases the product's resistance to certain climatic conditions. Note: conformal coating, where effective, will only mitigate the effects being considered.
EMC Compatibility (EMC Directive)	CE Marked in accordance with 2004/108/EC

Dimensions

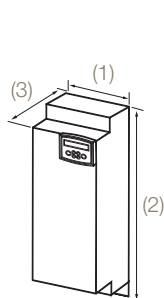

Frames B/C/D

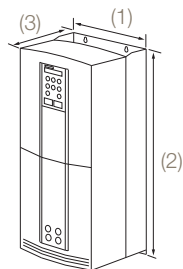

Frames E/F

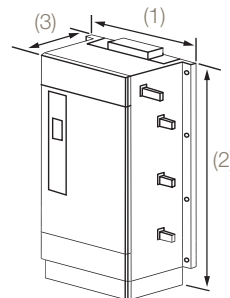

Frames G/H/J

Dimensions and Weights

Model	Width (1) [mm]	Height (2) [mm]	Depth (3) [mm]	Weight [kg]			
				890CS	890CD	890SD	
890 Frame B	72.4	433	258	3.5	5	6	
890 Frame C	116			Data not available	6.6	7.6	
890 Frame D	160			8.7	12.1	13.1	
890 Frame E	257	668	312	Data not available	32.5	33.5	
890 Frame F		720	355		41	42	
890 Frame G	456	1042	465		Data not available	Data not available	108
890 Frame H	572	1177					138
890 Frame J	675	1288					176

Connections

Power connections – Common DC Bus

AC890CS Common Bus Supply

Terminal	Description
L1	L1 AC Input Supply
L2	L2 AC Input Supply
L3	L3 AC Input Supply
¹ DC+ Bottom Terminal	DC Link Bus +Ve
¹ DC- Bottom Terminal	DC Link Bus -Ve
DBR+	Dynamic Brake Resistor
DBR-	Dynamic Brake Resistor

¹ A factory fitted safety bung is fitted to DC+ and DC- terminals which maintain the IP20 Rating. Leave this bung in place if using the DC bus connections on the top of the unit



AC890CD Common Bus Drive

Terminal	Description
M1/U	Motor Output 1/U
M2/U	Motor Output 2/U
M3/W	Motor Output 3/W
Motor Thermistor 1	PTC Type 'A' Thermistor
Motor Thermistor 2	PTC Type 'A' Thermistor
Mechanical Brake 1	0V Brake Supply
Mechanical Brake 2	24V Brake Supply
Mechanical Brake 3	Brake Coil -
Mechanical Brake 4	Brake Coil +

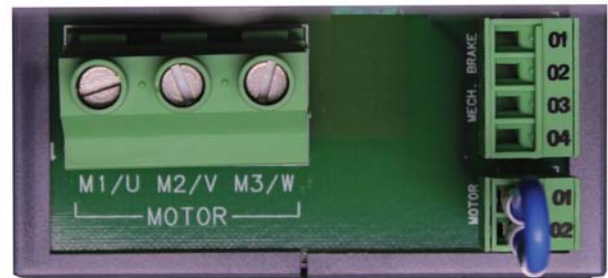

AC890CD Common Bus Drive

Terminal	Description
DC+ Top Terminal	DC Link Bus +Ve
DC- Top Terminal	DC Link Bus -Ve



Power connections – Standalone Drive

AC890SD Standalone Drive

Terminal	Description
Top Terminal Rail	
L1	L1 AC Input Supply
L2	L2 AC Input Supply
L3	L3 AC Input Supply
Brake DC+ / DBR+	Dynamic Brake Resistor
Brake EXT / DBR-	Dynamic Brake Resistor

Bottom Terminal Rail	
M1/U	Motor Output 1/U
M2/U	Motor Output 2/U
M3/W	Motor Output 3/W
DC+	DC Bus Link Monitoring
DC-	DC Bus Link Monitoring
Motor Therm. 1	PTC Type 'A' Thermistor
Motor Therm. 2	PTC Type 'A' Thermistor
Mech. Brake 1	0 V Brake Supply
Mech. Brake 2	24 V Brake Supply
Mech. Brake 3	Brake Coil -
Mech. Brake 4	Brake Coil +



AC890SD Top Power Terminals



890SD Bottom Power Terminals

Safe Torque Off (STO)

AC890 features STO functionality as standard, offering users protection against unexpected motor start-up in accordance with EN 13849-1 at PLe Cat 3 or SIL 3 to EN61800-5-2.

The STO functionality helps protect personnel and machinery by preventing the drive from restarting automatically. It disables the drive pulses and inhibits the power supply to the motor, so that the drive cannot generate any potentially hazardous movement. The state is monitored internally within the drive.

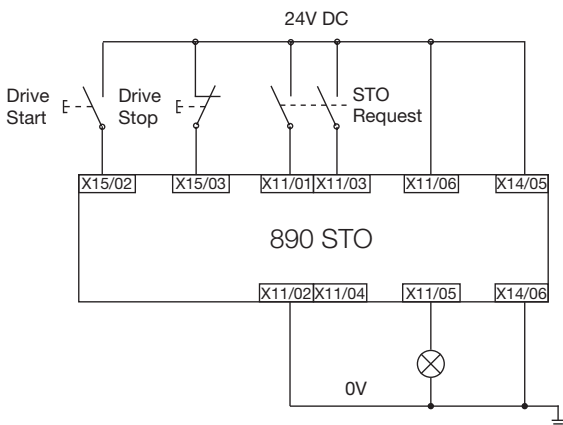

Term.	Description
X11/01	STO Channel A Input
X11/02	STO Common
X11/03	STO Channel B Input
X11/04	STO Common
X11/05	STO Status -Ve
X11/06	STO Status +Ve

The example wiring diagram shows the minimum connections required to implement STO with the AC890 Series of drives



It is the user's responsibility to ensure the safe and correct use of the STO functionality. Users should read and fully understand chapter 6 of the product user manual. Manual No. HA468445U004

AC890CS DC Power Supply Module

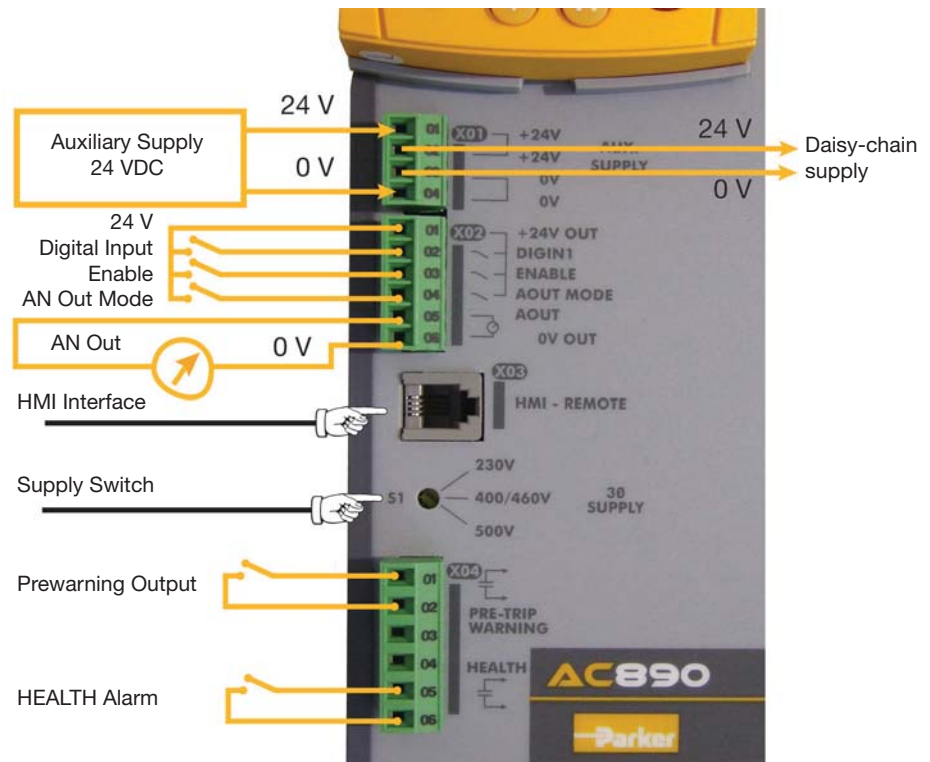

Term.	Label	Description
X01/01	+24 V Aux	+24 VDC Supply
X01/02	+24 V Aux	+24 VDC Daisy chain to next drive
X01/03	0 V Aux	0 VDC Common
X01/04	0 V Aux	0 VDC Daisy chain to next drive
X02/01	+24 V Out	24 VDC supply for X02 Digital I/O
X02/02	DIGIN1	Not used
X02/03	Enable	Enable power supply module
X02/04	AOUT MODE	0V = (kW), 24 V = (A) units for AOUT
X02/05	AOUT	0...10 V meter connection.
X02/06	0 V OUT	0 V reference for AOUT
X03	HMI	Port for remote keypad
S1	3 Ø Supply	Power supply voltage selection
X04/01	Pre-Trip	Pre-Trip warning volt free contact
X04/02	Pre-Trip	Pre-Trip warning volt free contact
X04/03		Not Used
X04/04		Not Used
X04/05	Health	Drive Healthy volt free contact
X04/06	Health	Drive Healthy volt free contact

AC890CS DC Power Supply Module

For detailed AC890 Series connection information, please consult the product manual HA468445U004.

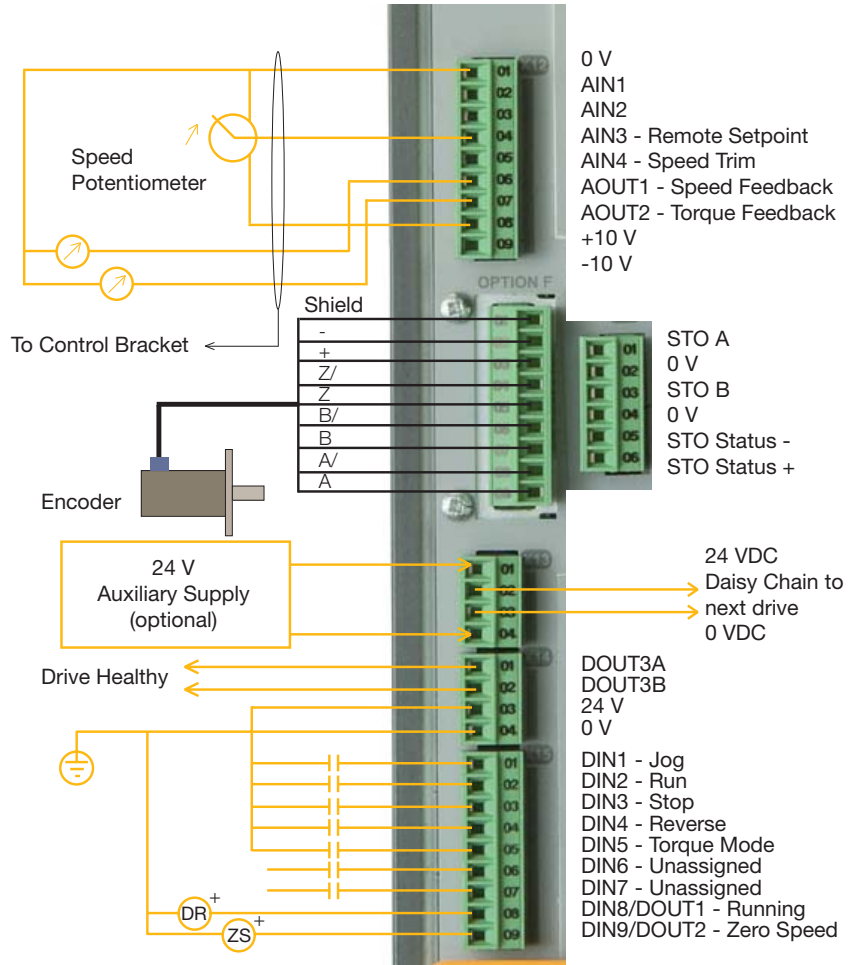

Term.	Label	Description
X12/01	0 V	0V reference for Analog I/O
X12/02	AIN1	0-10 V, ± 10 V Analog Input 1
X12/03	AIN2	0-10 V, ± 10 V Analog Input 2
X12/04	AIN3	± 10 V, 0-10 V, 0-20 mA, 4-20 mA Analog Input 3
X12/05	AIN4	± 10 V, 0-10 V, 0-20 mA, 4-20 mA Analog Input 4
X12/06	AOUT1	± 10 V Analog Output 1
X12/07	AOUT2	± 10 V Analog Output 2
X12/08	+10 V REF	+10 V Reference for Analog I/O
X12/09	-10 V REF	-10 V Reference for Analog I/O
X13/01	24 V Input	User +24 VDC (2 A)
X13/02	24 V Input	User +24 VDC (2 A)
X13/03	0 V Input	0 V Input
X13/04	0 V Input	0 V Input

Term.	Label	Description
X14/01	DOUT3A	Volt Free 24 V 1 A Relay Contact
X14/02	DOUT3B	Volt Free 24 V 1 A Relay Contact
X14/03	User 24 V	24 V DC Output 150 mA Load
X14/04	0 V	0 V Reference for User 24 V Output
X15/01	DIN1	24 V Digital Input 1
X15/02	DIN2	24 V Digital Input 2
X15/03	DIN3	24 V Digital Input 3
X15/04	DIN4	24 V Digital Input 4
X15/05	DIN5	24 V Digital Input 5
X15/06	DIN6	24 V Digital Input 6
X15/07	DIN7	24 V Digital Input 7
X15/08	DIN8/DOUT1	24 V Digital Input/Output 1
X15/08	DIN9/DOUT2	24 V Digital Input/Output 2

Accessories and Options

Communication Interfaces

8903-IP-00	Ethernet IP communication interface
Supported Protocols	Ethernet IP
Communication Speed	10/100 Mbits/s
Station Address	By Drive System Explorer software via RTNX protocol
Suitable for firmware	Version 3.2+

8903-IM-00	Ethernet Modbus/TCP communication interface
Supported Protocols	Modbus TCP
Communication Speed	10/100 Mbits/s
Station Address	By Drive System Explorer software via RTNX protocol
Suitable for firmware	Version 3.2+

8903-DN-00	DeviceNet communication interface
Supported Protocols	Supports the group 2 only slave subset of the DeviceNet protocol
Communication Speed	125 k, 250 k and 500 kbits/s
Station Address (MACID)	Dip switch or software setting of station address and network speed
Supported Messages	Polled I/O, Cyclic Outputs, Change of State (COS), Explicit Messaging
Suitable for firmware	Version 1.9+

8903-CB-00	CANopen communication interface
Profile	DS402
Communication Speed	20 k, 50 k, 125 k, 250 k, 500 k, 1 Mbits/s selectable by software or DIP switch setting
Station Address	DIP switch or software setting of station address and network speed
Supported Messages	SDO, PDO, NMT, SYNC
Suitable for firmware	Version 1.3+

8903-CN-00	ControlNet communication interface
Communication Speed	Selectable by software or DIP switch setting
Station Address	Software setting of station address
Supported Messages	Polled I/O
Suitable for firmware	Version 1.4+

8903-PB-00	PROFIBUS-DP communication interface
Supported Protocols	PROFIBUS-DP; Demand data and Data exchange
Communication Speed	Up to 12 Mbits/s; selected by the master
Station Address	DIP switch or software setting of station address
Suitable for firmware	Version 1.4+

8903-FA-00	Firewire IEEE 1394 communication interface
Communication Speed	Up to 400 MBaud
Communication Supported	Peer-to-peer communication between drives via IEEE 1394 standard
Suitable for firmware	Version 3.2+



Communication Interfaces

8903-PN-00	PROFINET I/O communication interface
Supported Protocols	PROFINET I/O Real-Time (RT) Protocol
Communication Speed	100 Mbits/s
Station Address	Software setting of station address via DSE
Suitable for firmware	Version 3.3+
8903-SP-00	CAN peer to peer communication interface
Supported Protocols	Peer to peer data exchange with other drives
Communication Speed	Up to 1 Mbits/s selectable by DIP switch
Station Address	Selected by DIP switch setting
Suitable for firmware	Version 3.3+
8903-CT-00	EtherCAT communication interface
Supported Protocols	CANopen over EtherCAT (CoE) DS301 compliant
Communication Speed	100 Mbits/s
Suitable for firmware	Version 3.7+
8903-RS-00	RS485 / Modbus communication interface
Supported Protocols	Modbus RTU only
Communication Speed	1200 to 115200 bits/s
Station Address	Selectable via software
Suitable for firmware	Version 3.7+



Feedback Cards

Incremental Quadrature Encoder Card 8902-EQ

8902-EQ-00-00	Optional HTTL Incremental Encoder
Maximum pulse rate	250 kHz (differential) 200 kHz (single ended)
Receiver current	≤10 mA per channel
Input Format	Two differential channels in quadrature (Clock/direction or clock only)
Input Voltage	±30 V (differential), 0...30 V (single-ended)
Input Voltage Differential	±30 V maximum
Input Voltage Threshold dip switch settings	3 V ±1 V (differential) 8 V ±1 V (single-ended)
Encoder Power Supply	Maximum load 200 mA or 2 W



Description

The HTTL 8902-EQ speed feedback option allows incremental encoders to be connected directly to the drive to provide highly accurate speed feedback measurement. Supplies variable voltage isolated encoder power supply.

Resolver Feedback Card 8902-RE

8902-RE-00-00	Optional Resolver feedback card
Maximum Speed	Up to 50 000 min ⁻¹ (with 2 pole resolver)
Carrier Output Signal	7 V _{rms} , 8 kHz
Maximum Carrier Supply	70 mArms
Maximum Input Voltage	±12 V _{peak}
Accuracy	<5 minutes
Resolution	Equivalent to 16 bits in one revolution of resolver
Inputs	Differential inputs Z _{in} ~2 kΩ
Maximum Input Voltage	12 V _{peak}



Description

The 8902-RE resolver speed feedback option allows the resolver to be connected directly to the drive to provide highly accurate speed feedback measurement. Contains a carrier output signal to power the resolver.

Feedback Cards

SinCos® EnDat2.1 Feedback Card 8902-E1

8902-E1-00-00	Optional SinCos® encoder card
Maximum Pulse Rate	250 kHz
Receiver Impedance	120 Ω
Input Format	two differential 1 V _{pp} signals in quadrature
Encoder Supply	Maximum load 250 mA Adjustable Voltage 5 V/10 V



Description

The SinCos® speed feedback option 8902-E1 allows a 1 V_{pp} SinCos® encoder to be connected directly to the drive to provide highly accurate speed feedback measurement. Decodes Heidenhain EnDat2.1 absolute position encoders and supplies 5 V or 10 V for the encoder.

SinCos® registration position 8902-M1 and 8903-M1

8902-M1-00	Slave SinCos® registration
8903-M1-00	Master SinCos® registration
Maximum Pulse Rate	250 kHz
Receiver Impedance	120 Ω
Input Format	2 differential 1 V _{pp} signals in quadrature
Encoder Supply	250 mA maximum load
Supply Voltage	5 V/10 V adjustable
Terminal Type	Sub-D15 connector
Maximum Cable Length	150 m screened cable
Serial Protocol	EnDat2.1



Description

- The 8903-M1-00 and 8902-M1-00 feedback cards allow operation without external registration position, thanks to the connection of the encoder to the drive. They provide highly accurate speed feedback measurement and registration. Nevertheless registration applications are best achieved when both cards are used.
- Interpolates each encoder line with 11-bit accuracy giving 4 million counts/rev. on a 2048 line encoder
- Supplies 5 V or 10 V to the encoder
- Decodes Heidenhain EnDat2.1 absolute position encoders
- Isolated digital inputs that can be used either for general purpose inputs, or for inputs from registration mark sensor (8903-M1 only)
- 3 non-isolated digital outputs that can be either for general purpose outputs or for synthesizing an encoder output (8903-M1 only)

Approved Encoders

	1 V _{pp}	EnDat2.1	Single turn ABS	Multi-turn ABS
Heidenhain:				
ECN113	√	√		√
ECN1113	√	√	√	
EQN425	√			
ECN413				
ERN480				
Stegmann:				
HG660 AKR (xxxx)S	√			
HG660 DKR (xxxx)S	√			
Hengstler:				
RIS58-H				

Input and Output Cards

Auxiliary digital input (8903-M1... only)

Low Logic Level	0 V to 5 V relative to X63 pin 5
High Logic Level	15 V to 26 V relative to X63 pin 5
Maximum Input Voltage	30 V relative to X63 pin 5
Input Current	Low logic level <1 mA High logic level >3 mA, <10 mA Typical input at 24 V: 7 mA
Isolation withstand relative to drive chassis	30 V
Input Safety Category	SELV
Terminal Type	6-way pluggable 3.5 mm terminal block
Maximum Cable Length	150 m screened cable is recommended for all lengths, but essential if over 30 m in order to comply with EMC regulations

Auxiliary digital outputs (8903-M1... only)

Input Voltage (VS)	5 V to 24 V
Maximum Input Voltage	30 V
Maximum Output Current	±100 mA per output
Output Voltage	Low logic level <3 V to 100 mA High logic level >VS – 4 V to 100 mA
Overload and short circuit duration	Indefinite withstand
Max. Output Frequency	250 kHz per output
Terminal Type	8-way pluggable 3.5 mm terminal block
Maximum Cable Length	150 m screened cable is recommended for all lengths, but essential if over 30 m in order to comply with EMC regulations



High Resolution Analogue Input 8903-AI and 8903-EP Encoder Card

8903-AI-00-00	High Resolution Analogue Input Card
8903-EP-00-00	Encoder Card
Maximum pulse rate	250 kHz
Receiver current	≤10 mA per channel
Input Format	Two differential channels in quadrature (Clock/direction or clock only)
Input Voltage	±30 V (differential), 0-30 V (single-ended)
Input Voltage Threshold dip switch settings	3 V ±1 V (differential) 8 V ±1 V (single-ended)
Encoder Power Supply	Maximum output current ±100 mA per output

High Resolution Analogue Input 8903-AI Only

Analogue Input	
Resolution	15 bits + sign bit
Input Voltage Range	±11 V
Input Format	Differential
Input Impedance	100 kΩ
Input Low Pass Filter	3 kHz
Encoder Power Supply	Maximum output current ±100 mA per output

Description

The high resolution Analog Input Option adds a sixth analogue input to the AC890PX Modular Chassis drive. This input can be used, as the other inputs, within a configuration or directly as the speed setpoint for a fast response time.

In addition to this Analog Input the 8903/AI option provides an incremental encoder input as well as an incremental encoder output.

The 8903/EP Encoder Option has the same functionalities of the 8903/AI except for the analogue input.

Anciliary Parts

AC Input Chokes

Parker's range of AC input chokes have been especially selected to match the requirements of the Parker AC drive range and are used to reduce the harmonic content of the supply current.

Nominal 400 VAC

Model Number	[kW]	Input Current [A]	Inductance [μ H]	Order code
890PXSA-43215	110	230	100	CO501691U411
890PXSA-43260	132	270	90	CO501691U413
890PXSA-43300	160	340	80	CO501691U416
890PXSA-43420	200	425	55	CO501691U420
890PXSA-43480	250	535	45	CO501691U425
890PXSA-43520	280	600	40	CO501691U428
890PXSA-43580	315	680	35	CO501691U431

For other voltages please contact your local sales office.



Output Chokes

To limit capacitive currents and prevent nuisance tripping in installations with longer cable runs over 100 m, a choke may be fitted to the drives output. This limits the capacitive current and prevents overcurrent trips and excessive temperature rise in the motor. These may be used with 380/460 V and 500/575 VAC drives.

Motor Choke Maximum Current	Order Code
250 A	CO471702U250
320 A	CO471702U320
400 A	CO471702U400
500 A	CO471702U500
600 A	CO471702U600
700 A	CO471702U750



Auxiliary Transformers

1 kVA 30 VAC control transformer for auxiliary power supply requirements.

Supply Voltage	Order Code
400-480 VAC	C0501514
500-690 VAC	C0501515



EMC Filter

A range of custom designed optional EMC (Electromagnetic Compatibility) filters are available for use with Parker SSD Drives product range. They are used to help achieve conformance with the EMC directive BS EN 61800-3:2004 - "Adjustable speed electrical power drive systems - Part 3".



Rating	Order Code
Up to 132 kW	CO467843U340
Up to 315 kW	2-off CO467843U340

AFE 4 Quadrant

In many applications the overall power consumed by the system is less than the sum of power of the installed motors as some motors will be driven electrically while others are coasting, being driven by the momentum of the machine.

For such applications, it is beneficial to connect the drives of all sections of the machine to a common DC bus: the energy-generating sections are then fed into the energy-consuming sections, which reduces the overall energy consumption of the system.



Thanks to the 4 quadrant (4Q) functionality of the AC890PX-Series, excess energy in the system is returned to the network and not dissipated in the form of heat through braking resistors. The current waveforms are almost sinusoidal, which minimizes network harmonics

Rating	Filter Assembly 110 V fans & control	Filter Assembly 230 V fans & control	L1 (5 %)	L2 (3 %)
Nominal 400 VAC				
Up to 180 kW	LA482468U220	LA482471U220	CO468326U220	CO468325U220
Up to 280 kW	LA482468U315	LA482471U315	CO468326U315	CO468325U315
Up to 315 kW	LA482468U355	LA482471U355	CO468326U355	CO468325U355
Nominal 500 VAC				
Up to 180 kW	LA482469U220	LA482472U220	CO468326U220	CO468325U220
Up to 280 kW	LA482469U315	LA482472U315	CO468326U315	CO468325U315
Up to 315 kW	LA482469U355	LA482472U355	CO468326U355	CO468325U355

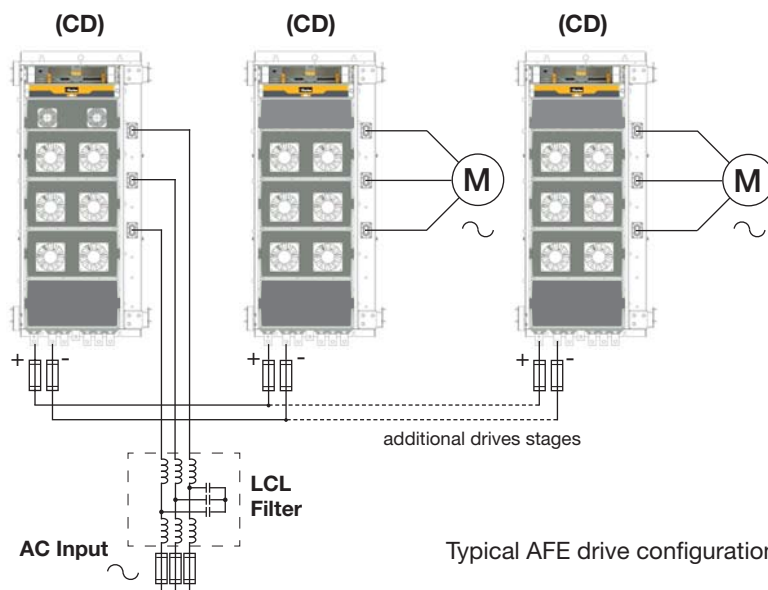

Drive System Explorer (DSE) Software

Description

DSE890 is the programming, monitoring and diagnostic software platform for AC890 and AC890PX series variable speed drives.

Communication between the drive and PC is via a mini USB port located on the front of the drive.

Thanks to the on-line help, users can achieve the optimum drive configuration without the need to navigate through complicated parameter menus.

Advanced programming is carried out through a set of pre-engineered templates in order to create the required configuration.

It is possible to monitor every parameter of the drive either as a digital value or as a function in the "chart recorder" during normal operation. Creates projects quickly and easily

- Graphical tool based on a block diagram approach
- Integrated digital oscilloscope
- On-line configuration and monitoring
- System identification tool

DSE890 Programming Software

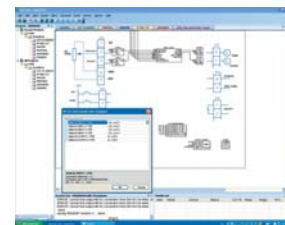
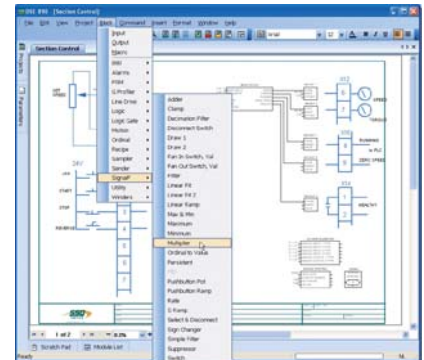

Parameter adjustment and project creation

Product Codes

DSE Lite software (single axis) + USB cable	8906-DSELITE-00
DSE Development software + USB cable	8906-DSEDEV-00
DSE Runtime/Maintenance + USB cable	8906-DSERUN-00
DSD to DSE Development Upgrade + USB cable	8906-DSEDE
DSD Runtime to DSE Runtime Upgrade + USB cable	906-DSERUNUPG-00

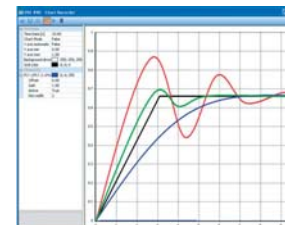

real-time data acquisition oscilloscope

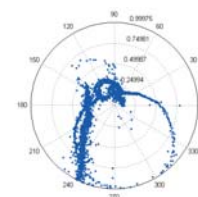
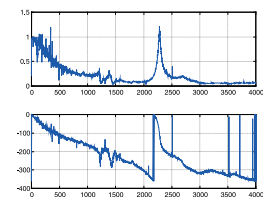

System identification tool

Order Code

AC890CS – Common Bus Power Supply

	1		2	3		4	5		6	7		8
Order example	890CS	-	53	2320	-	B	0	-	B	00	-	U

1 Drive Type	890CS	Common Bus Power Supply
2 Voltage	53	400 / 500V Nominal
3&4 Current Rating and Frame	2320-B	32 A
	2540-B	54 A
	3108-D	108 A
	3162-D	162 A

5 Auxiliary Supply	0	None
6 Brake Switch	0	Fitted as standard
7 Special Options	00	Not Fitted
Language	U	English (50/60 Hz)

AC890CA – Common Bus Adapter

	1		2	3		4	5		6	7		8
Order example	890CA	-	53	2500	-	B	0	-	R	00	-	U

1 Product Family	890CA	Common Bus Adaptor
2 Voltage	53	400 / 500 V Nominal
3&4 Current Rating and Frame	2500-B	50 A
	2800-B	80 A

5 Auxiliary Supply	0	None
6 Hardware Characteristics	0	None
	R	Ride through capacitors (50 A Only)
7 Special Options	00	Not Fitted
8 Language	U	English (50/60 Hz)

AC890CD – Common Bus Drive

	1		2	3	4	5		6	7		8	9	10	11	12
Order example	890CD	-	23	1300	B	0	-	B	00	-	1	A	0	0	0

1	Drive Type	
	890CD	Common Bus Drive
2	Voltage	
	23	230 V Nominal
	43	400 V Nominal
	53	500 V Nominal
3 & 4	Current Rating and Frame	
	1300 B	0.55 kW (230 V Nominal Supply)
	1550 B	1.1 kW (230 V Nominal Supply)
	1700 B	1.5 kW (230 V Nominal Supply)
	2110 B	2.2 kW (230 V Nominal Supply)
	2165 B	4.0 kW (230 V Nominal Supply)
	2240 C	5.5 kW (230 V Nominal Supply)
	2300 C	7.5 kW (230 V Nominal Supply)
	1200 B	0.55 kW (500 V Nominal Supply)
	1350 B	1.1 kW (500 V Nominal Supply)
	1450 B	1.5 kW (500 V Nominal Supply)
	1600 B	2.2 kW (500 V Nominal Supply)
	2100 B	4.0 kW (500 V Nominal Supply)
	2120 B	5.5 kW (500 V Nominal Supply)
	2160 B	7.5 kW (500 V Nominal Supply)
	2240 C	11 kW (500 V Nominal Supply)
	2300 C	15 kW (500 V Nominal Supply)
	2390 C	18.5 kW (500 V Nominal Supply)
	2450 D	22 kW (500 V Nominal Supply)
	2590 D	30 kW (500 V Nominal Supply)
	2730 E	37/45 kW (400 V / 500 V Nominal Supply)
	2870 E	45/55 kW (400 V / 500 V Nominal Supply)
	3105 F	55/75 kW (400 V / 500 V Nominal Supply)
	3145 F	75/90 kW (400 V / 500 V Nominal Supply)
	3156 F	90/110 kW (400 V / 500 V Nominal Supply)
	3156 F	90 kW (500 V Nominal Supply)
	3180 F	90 kW (500 V Nominal Supply)
5	Auxiliary Supply	
	0	None
	1	115 V single phase (Frame F only)
	2	230 V single phase (Frame F only)

6	Brake Switch	
	0	Not Fitted
7	Special Options	
	00	Not Fitted
	07	Active Front End ('Y' caps removed Frames E & F only)
	XX	Documented special options 01-99, (contact your local sales office)
8	Performance	
	1	Advanced
	2	High
9	Language	
	A	English (50 Hz)
	B	English (60 Hz)
10	Option F	
	0	Not Fitted
	1	SinCos Encoder (Endat 2.1)
	3	Incremental Quadrature Encoder
	5	Resolver
	6	Resolver feedback with repeater output
	7	8902/M1 Sin/Cos Registration
11	Option A	
	0	Not Fitted
	N	CANopen
	C	ControlNET
	D	DeviceNET
	H	Ethernet IP
	T	Modbus/TCP
	P	Profibus
	F	Profinet
	S	RS485 / Modbus
	E	Encoder with repeater output
	R	Analogue Input
	7	8903/M1 Sin/Cos Registration
12	Option B	
	0	Not Fitted
	A	Firewire 1394A
	X	SP- Peer to Peer Communications (Not available if N or D selected in Option A)
	E	Encoder with Repeater Output
	R	Analogue Input Option

AC890SD – Stand Alone Drive

	1		2	3	4	5		6	7		8	9	10	11	12
Order example	890SD	-	43	2730	B	0	-	B	00	-	1	A	0	0	0

1	Drive Type	890SD Standalone AC890 Drive
2	Voltage	23 230 V Nominal 43 400 V Nominal 53 500 V Nominal
3 & 4	Current Rating and Frame	1300 B 0.55 kW (230 V Nominal Supply) 1200 B 0.55 kW (500 V Nominal Supply) 1550 B 1.1 kW (230 V Nominal Supply) 1350 B 1.1 kW (500 V Nominal Supply) 1700 B 1.5 kW (230 V Nominal Supply) 1450 B 1.5 kW (500 V Nominal Supply) 2110 B 2.2 kW (230 V Nominal Supply) 1600 B 2.2 kW (500 V Nominal Supply) 2165 B 4.0 kW (230 V Nominal Supply) 2100 B 4.0 kW (500 V Nominal Supply) 2240 C 5.5 kW (230 V Nominal Supply) 2120 C 5.5 kW (500 V Nominal Supply) 2300 C 7.5 kW (230 V Nominal Supply) 2160 C 7.5 kW (500 V Nominal Supply) 2240 C 11 kW (500 V Nominal Supply) 2300 C 15 kW (500 V Nominal Supply) 2390 C 18.5 kW (500 V Nominal Supply) 2450 D 22 kW (500 V Nominal Supply) 2590 D 30 kW (500 V Nominal Supply) 2730 E 37/45 kW (400 V / 500 V Nominal Supply) 2870 E 45/55 kW (400 V / 500 V Nominal Supply) 3105 F 55/75 kW (400 V / 500 V Nominal Supply) 3145 F 75/90 kW (400 V / 500 V Nominal Supply) 3156 F 90/110 kW (400 V Nominal Supply) 3156 F 90 kW (500 V Nominal Supply) 3180 F 90 kW (400 V Nominal Supply) 3216 G 110/132 kW (400 V Nominal Supply) 3250 G 132/150 kW (400 V Nominal Supply) 3316 G 160/180 kW (400 V Nominal Supply) 3361 G 180/220 kW (400 V Nominal Supply) 3375 H 200/250 kW (400 V Nominal Supply) 3420 H 220/250 kW (400 V Nominal Supply) 3480 H 250/300 kW (400 V Nominal Supply) 3520 H 280/315 kW (400 V Nominal Supply) 3590 J 315/355 kW (400 V Nominal Supply)

5	Auxiliary Supply	0 None 1 115 V single phase (Frame F - J only) 2 230 V single phase (Frame F - J only)
6	Brake Switch	0 Not Fitted
7	Special Options	00 Not Fitted 07 Active Front End ('Y' caps removed Frames E & F only) XX Documented special options 01-99, (contact your local sales office)
8	Performance	1 Advanced 2 High
9	Language	A English (50 Hz) B English (60 Hz)
10	Option F	0 Not Fitted 1 SinCos Encoder (Endat 2.1) 3 Incremental Quadrature Encoder 5 Resolver 6 Resolver feedback with repeater output 7 8902/M1 Sin/Cos Registration
11	Option A	0 Not Fitted N CANopen C ControlNET D DeviceNET H Ethernet IP T Modbus/TCP P Profibus F Profinet S RS485 / Modbus E Encoder with repeater output R Analogue Input 7 8903/M1 Sin/Cos Registration
12	Option B	0 Not Fitted A Firewire 1394A X SP- Peer to Peer Communications (Not available if N or D selected in Option A) E Encoder with Repeater Output R Analogue Input Option

High Power AC Variable Speed Drive - AC890PX-M Series Modular Chassis Drive

Overview

Description

AC890PX-M Modular Chassis High Power AC Drive is supplied in a kit format for assembly into a standard Rittal TS range industrial enclosure. This enables system integrators and panel builders to add any number of drive sections into their standard electrical control systems, thereby reducing overall enclosure size and complexity.

The AC890PX-M Modular Chassis kit is supplied complete with all of the necessary individual components and fixings required to complete the assembly of the drive. It can easily be assembled by a technician with minimal drives technical knowledge

Features

- AC Fed (SD) or DC Fed (CD) modular design configuration
- Power range 110 - 400 kW
- Sold in kit format for self-assembly
- Easy integration into power drive systems



Drive shown part assembled

Technical Characteristics - Overview

The AC fed (SD) version of the AC890PX-M Modular Chassis drive is available with three AC input power supply options to suit individual requirements.

Version	400 V nominal	600 V nominal	700 V nominal
Power Supply	380...480 VAC kW ratings @400 VAC 50 Hz HP ratings @460 VAC 60 Hz	500...575 VAC HP ratings @575 VAC 60 Hz	600...690 VAC kW ratings @690Vac 50 Hz
Heavy Duty	110...315 kW, 215...580 A 150...500 HP, 200...580 A	110...315 kW, 160...410 A 200...400 HP, 160...410 A	110...315 kW, 130...340 A 200...400 HP, 130...340 A
150 % overload for 60 s			
Normal Duty	132...400 kW, 260...700 A 200...600 HP, 250...700 A	132...400 kW, 170 - 440 A 200...500 HP, 240 - 500 A	132...400 kW, 160 - 430 A 200...500 HP, 160 - 430 A
110 % overload for 60 s			

Range Overview

The AC890PX-M Modular Chassis Drive is a high performance, high power modular drive designed to control 3-phase induction or permanent magnet AC motors, or to be used as an active front-end with power ratings ranging from 110 kW...2000 kW. It can be supplied either in modular kit form, or as a packaged drive system.

AC890PX-M Modular Chassis High Power AC Drive: 110...400 kW

The AC890PX-M Modular Chassis drive has been designed to be sold in kit form for assembly by a system integrator or panel builder. The product is engineered for easy assembly into a standard industrial enclosure with all necessary fixing brackets supplied as part of the kit.

The AC890PX-M Modular Chassis drive offers systems builders the flexibility to add all ancillary components in order to tailor the product to meet their customers needs.

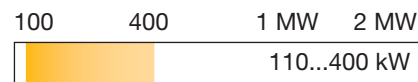

Packaged Drive Options - Factory Supplied



AC890PX-M Modular FASTPACK simple packaged drive system: 110...400 kW

The AC890PX-M Modular FASTPACK provides users with a ready-to-install standalone drive in an industrial enclosure complete with all additional control equipment up to 900 kW. FASTPACK delivers an integrated packaged solution for single motor applications on short lead times. A range of standard pre-engineered control and communications options can be specified to complete the package and provide the necessary control and feedback, whatever the application.

FASTPACK can also be provided as an Active Front End (AFE) system for use in power conversion or Grid-Tie applications.



AC890PX-C Modular Advanced-Cooled AC Systems Drive: 500 kW...2 MW

Higher power ratings of up to 2 MW can be achieved using Parker's innovative advanced-cooled 'PowerPak' modules. These larger drives use the same modular construction as the rest of the AC890PX-M Modular Chassis drive range but are supplied with Parker's 2-phase advanced cooling system, which uses a non-conductive liquid refrigerant. This enables power density to be increased significantly, resulting in a significantly smaller footprint than can be achieved by air-cooling alone.

Product Description

The AC890PX-M Modular Chassis is a modular high power AC drive platform designed for industrial applications with power requirements ranging from 110 kW up to 2000 kW. Available in kit form for integration into a standard control enclosure, or as a packaged standalone air-cooled or 2-phase liquid refrigerant cooled drive, AC890PX-M Modular Chassis drives can be configured for use in a wide range of applications and industries.

Compact Modular Design

The plug-in modular nature of the AC890PX-M Modular Chassis makes it easy to configure the drive to suit a number of alternative input power configurations including 12/18 pulse and Active Front End (AFE). The 'PowerPak' phase modules, common supply modules, capacitor and control module can be arranged to suit the particular requirements of the application.



PowerPak Phase Module



Low-maintenance ensures maximum machine up-time and productivity

Thanks to a plug-in design, the power modules of the AC890PX-M Modular Chassis drive has been designed to be replaceable in minutes by any technician, even a non-specialist. These lightweight, ship anywhere modules help to reduce machine or process downtime and lost productivity in the event of a fault occurring.

AC890PX-M Modular Chassis drives can be configured with different PowerPak module combinations dependant upon the application.

CP Module

The capacitor module is only fitted to 400 kW drives and provides extra capacitance for the DC bus.

CD Module

These output modules each provide a single phase of the complete drive and can be interchanged with each other.

CS Module

A 3-phase input rectifier containing a half-controlled diode/thyristor bridge. This module supplies DC to the three CD modules and also includes an integral dynamic brake switch.

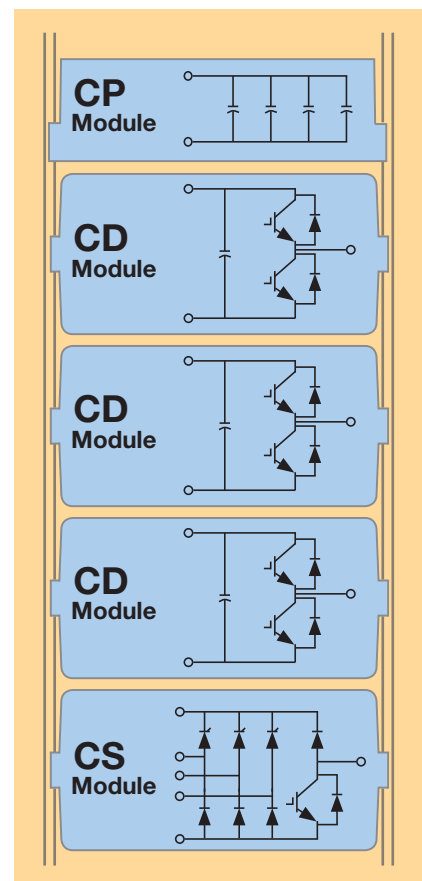

Features and Benefits

AC890PX-M Modular Chassis drive can be configured for five modes of operation allowing the appropriate level of control to be selected for the motor and application:

- **Open-loop V/F speed control**
This is the simplest form of control available and is ideal for motor speed control where an AC induction motor is controlled by varying the voltage and frequency supplied to the motor.
- **Sensorless flux vector control**
A ultra high performance sensorless vector algorithm, delivers a combination of both high torque and close speed regulation without the need for any speed measuring transducer.
- **Closed-loop flux vector control**
Full closed-loop flux vector performance can be achieved by simply adding an encoder feedback 'technology box'. This provides 100 % continuous full load standstill torque, plus a highly dynamic speed loop more than sufficient for the most demanding of applications.
- **Servo control**
Extremely fast control loops and process bus make the AC890PX-M Modular Chassis drive ideal for single Permanent magnet AC motor control.
- **4 Quadrant active front-end power supply module**
The drive is used to feed energy back into the mains supply with sinusoidal currents and unity power factor with very low levels of harmonic distortion.



Suitable for use with AC induction and PMAC motors

AC890PX-M Modular Chassis drive can control any of the following motor types, offering total flexibility of motor selection, allowing the most suitable motor to be selected for the application:

- AC Induction motors
- PMAC servo motors
- Torque Motors
- High speed PMAC servo motors

Compatible with a wide range of feedback options

Thanks to a range of optional feedback cards, AC890PX-M Modular Chassis drive works with all types of popular feedback systems providing greater flexibility during the design stage of a project:

- Incremental encoder
- Resolver
- SinCos (Endat 2.1) encoder
- Absolute encoder EnDat2.2 option 02



AC induction motors



PMAC brushless motors



Torque motors



High speed PMAC motors

AC890PX-M Control Module

At the heart of the AC890PX-M Modular Chassis drive is a highly advanced control module that manages all of the drives functions. Taking advantage of leading edge control algorithms running on a fast 150 MHz microprocessor, the drive can achieve very high-bandwidth control loops. This allows you to use the drive for the most demanding of industrial applications.

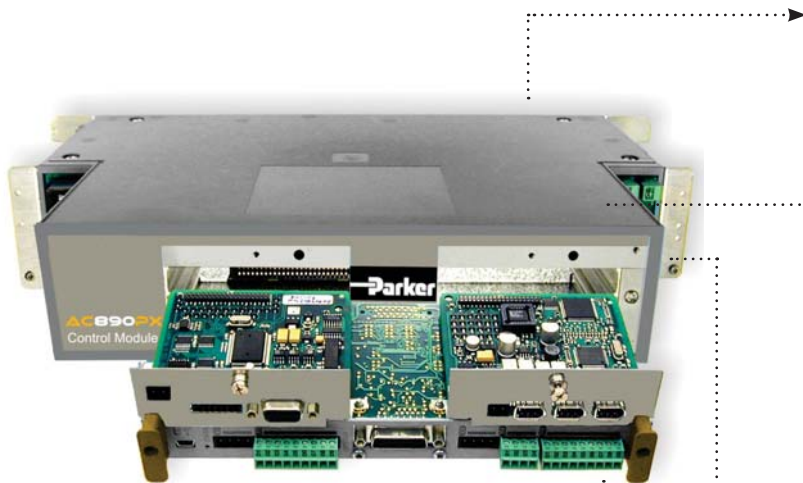

Features

Support for popular industrial fieldbus networks



Range of feedback options

- Incremental encoder
- EnDat® 2.2 option 02 (SinCos) encoder
- Resolver

Ultra-fast control loops

- Torque loop: 62.5 μ s
- Speed loop: 62.5 μ s
- Position loop: 62.5 μ s

Open FireWire IEEE 1394 Process Port

- 125 μ s cycle time
- Real-time synchronization between drives

Benefits

Integrated safety functionality

The integrated Safe Torque Off (STO) functionality offers protection against unexpected motor start-up, in accordance to EN 13849-1 PLe, SIL 3 as standard.

Minimal delay between fieldbus setpoints and the control loops

Designed to integrate in existing automation systems, the AC890PX-M Modular Chassis drive features high performance ports linked directly to the fast control loops of the drive. Minimum delay exists between your digital setpoint sent through a fieldbus and the control loops.

Flexible feedback options

The AC890PX-M Modular Chassis drive offers system designers complete flexibility in their choice of feedback technology to best suit the needs of their application.

Open standards for protection of investment

The AC890PX-M Modular Chassis drive has been specifically designed to integrate seamlessly into your automation network with the addition of a communications interface.

Two performance levels to suit all applications:

Advanced Performance

Motion control with position control,
Motion control function blocks: incremental move, absolute move, move home
Section Control: line drive master ramp, winder blocks (speed and current winder), PID process, sequencer control.

High Performance

All advanced features plus:
Library of pre-engineered application specific LINK VM function blocks such as:
Shaftless printing, cut-to-length, advanced winding and advanced traversing.

Tools

Programming / Operator Controls

The AC890PX-M Modular Chassis drive operator keypad provides access to all of the drive's functions in a logical and intuitive manner. The backlit display presents all functions in plain language and engineering units. PLC-like function blocks for advanced applications.

- Multilingual
- Quick setup menu
- Auto-tuning
- Diagnostic messages
- Drive configuration



Drive System Explorer (DSE)

DSE software allows users to program, configure, monitor and diagnose AC890PX-M drives with the use of a PC. An easy to use interface guides the user through every step of project creation and implementation.

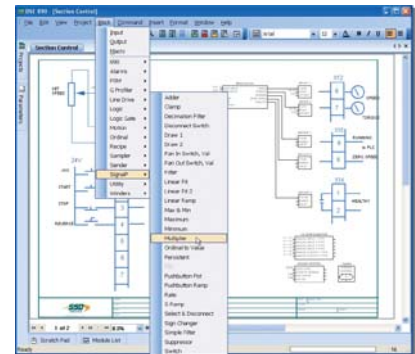

Applications











AC890PX-M Modular Chassis drives are suited to many different motor control and power conversion applications where power density and compactness are key design considerations:

- Fan and pump control
- Automotive test stands
- Extruders
- Decanter and batch centrifuges
- Hoists and cranes
- Winder/un-winder stands
- Ski-lifts and cable cars
- Wind turbine grid-tie
- Offshore and marine
- Solar energy capture
- Ocean / wave energy grid-tie



Component List Overview

The following is an overview of the parts supplied as part of a AC890PX-M Modular Chassis kit. The actual contents will vary dependant upon the configuration and rating of the product ordered.

Qty	Description	
1	Backplate Busbar Assembly	
1	Pair of mounting rails	
	Set of TS8 mounting brackets and assembly screws	
	Vent hood	
1	AC890 series control module	
	AC890PX-Series STO card	
1	CS module (AC890PXS only)	
3	CD module	
1	CP module (400 kW only)	
1	Set of control cables	

Technical Characteristics

Power Ratings

Model Variant	Asynchronous motors				PMAC Servo motors	
	Heavy Duty [kW/HP]	Normal Duty [kW/HP]	Heavy Duty [A]	Normal Duty [A]	Heavy Duty [A]	Normal Duty [A]
Nominal 400 VAC modules / 565 VDC						
890PX**-43215..	110/147	132/177	215	260	155	190
890PX**-43260..	132/177	160/214	260	340	185	245
890PX**-43300..	160/214	200/268	300	390	210	285
890PX**-43420..	200/268	250/335	420	480	295	350
890PX**-43480..	250/335	315/422	480	600	340	435
890PX**-43520..	280/375	355/476		660	365	475
890PX**-43580..	315/422	400/536	580	720	410	520
Nominal 460 VAC modules / 650 VDC						
890PX**-43215..	112/150	149/200	200	250	140	180
890PX**-43260..	149/200	187/250	250	320	175	230
890PX**-43300..	187/250	224/300	300	380	210	275
890PX**-43420..	224/300	298/400	380	480	270	350
890PX**-43480..	298/400	298/400	460	590	325	425
890PX**-43580..	373/500	448/600	580	700	405	505
Nominal 575 VAC modules / 810 VDC						
890PX**-63160..	112/150	149/200	160	210	90	120
890PX**-63210..	149/200	187/250	210	250	115	145
890PX**-63260..	224/300	224/300	260	310	140	180
890PX**-63310..	112/150	298/400	310	420	170	240
890PX**-63410..	298/400	298/400	410	480	220	275
Nominal 690 VAC modules / 975 VDC						
890PX**-73130..	110/147	132/177	130	160	60	85
890PX**-73160..	132/177	160/214	160	190	75	105
890PX**-73190..	160/214	200/268	190	240	85	130
890PX**-73230..	200/268	250/335	230	280	105	150
890PX**-73280..	250/335	315/422	280	340	125	185
890PX**-73320..	280/375	355/476	320	390	145	210
890PX**-73340..	315/422	400/536	340	430	155	235

See Ordering Information for full order codes and description



Electrical Characteristics

AC890PX-M Modular Chassis Drive

Power Supply Requirements

Power Supply	400 V Nominal	600 V Nominal	700 V Nominal
Rated Input Voltage	3 Ø 300...460 VAC ±10 %	3 Ø 500...575 VAC ±10 %	3 Ø 600...690 VAC ±10 %
Input Frequency	45...65 Hz		
Maximum Switching Frequency	2 kHz (standard), adjustable to 4 kHz de-rating may apply		
Overload: Heavy Duty	150 % for 60 seconds		
Overload: Normal Duty	110 % for 60 seconds		
Output Frequencies	0...1000 Hz in V/Hz mode		
	0...350 Hz in Closed loop vector mode		
	0...120 Hz in Sensorless vector mode		
Earth Leakage Current	>100 mA		
Input Power Factor	0.94		

Auxiliary Supply Requirements

Auxiliary Voltage	24 VDC		
Control Module and Fans	30 W		
Tech Cards - Speed Feedback	8902/EQ: Encoder Quadrature Incremental - 8 W		
	8902/E1: Sin/Cos Encoder - 3.3 W		
	8902/M1: Mark Registration - 1 W +5 V plus upto 3 W +24 V supply		
	8902/RE: Resolver - 3.2 W		
	8902/RR: Resolver + Repeater - 4.4 W		
Tech Cards - Communications	8903/DN: Devicenet, 8903/CB: CANopen, 8903/CN: ControlNet, 8903/SP: Peer to peer	1.3 W	
	8903/PB: Profibus	2.3 W	
	8903/NIM: Modbus/TCP, 8903/IP: Ethernet IP, 8903/PB: Profinet	1.6 W	

Environmental Characteristics

Operating Temperature	0 to +40 °C, derate up to a maximum of +50 °C
Storage Temperature	-25 to +55 °C
Shipping Temperature	-25 to +70 °C
Product Enclosure Rating	IP20/ NEMA 1 standard
Altitude	1000 m ASL. Derate output current by 1.5 % per 100 m to a maximum of 2000 m
Operating Humidity	Maximum 90 % relative humidity at 40 °C non-condensing
Climatic Conditions	Class 3k3, as defined by EN60721

Standards and Conformance

Pollution Degree	Pollution degree II (non-conductive pollution, except for temporary condensation)
Europe	This product conforms with the Low Voltage Directive 2006/95/EC
EMC Compatibility	CE Marked to EN618000-3 (EMC Directive)
Safety	SIL3 / PLe as per EN13849-1

Dimensions

The AC890PX-M Modular Chassis Drive has been designed to mount in a standard 600 x 600 mm Rittal TS8 cubicle. The mounting system is sufficiently flexible to allow the AC890PX-M to be installed in other floorstanding enclosure with minimal modification. If the product is to be mounted in a wider or deeper cubicle then additional brackets may be required to form a rigid frame. Refer to booklet HM501225U001 for detailed assembly and mounting instructions.

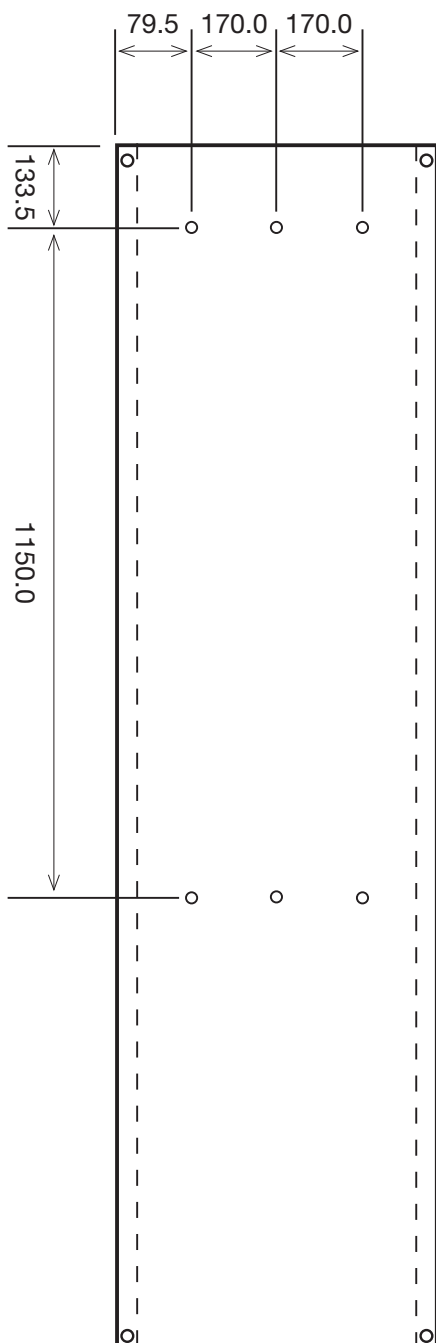

Power Rating	Length (mm)	Width (mm)	Depth (mm)	Weight
110 kW	1150	500	515	135 kg
132 kW	1150	500	515	135 kg
160 kW	1150	500	515	135 kg
200 kW	1150	500	515	135 kg
250 kW	1150	500	515	135 kg
280 kW	1150	500	515	155 kg
315 kW	1150	500	515	155 kg
Power Ratings are based on 400V nominal supply, constant torque ratings				
All dimensions and weights are approximate.				

Drawing shows TS8006 backplate

Connections

Power connectors

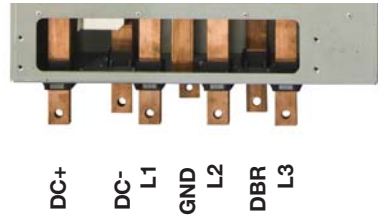
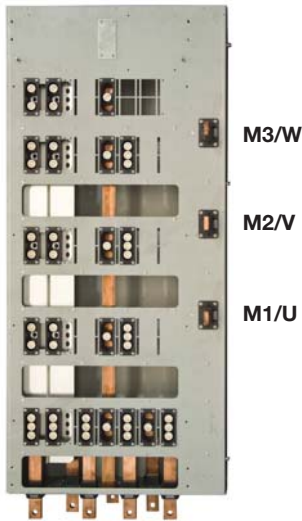

Term.	Description
DC+	DC Link Bus +Ve
DC-	DC Link Bus -Ve
L1	L1 AC Input Supply
GND	Earth
L2	L2 AC Input Supply
DBR	Dynamic Brake Resistor
L3	L3 Ac input Supply
M1/U	Motor Output U
M2/V	Motor Output V
M3/W	Motor Output W

Safe Torque Off (STO)

The AC890 series features Safe Torque Off functionality as standard, offering users protection against unexpected motor start-up in accordance with EN 13849-1 PLe or SIL 3.

The STO functionality helps protect personnel and machinery by preventing the drive from restarting automatically. It disables the drive pulses and disconnects the power supply to the motor, so that the drive cannot generate any potentially hazardous movement. The state is monitored internally within the drive.

Term.	Label	Description
X11/01	STOA	To disable STO: connect to X14/03
X11/02	STO 0V	To disable STO: do not connect
X11/03	STO B	To disable STO: connect to X14/03
X11/04	STO 0V	To disable STO: connect to X14/04
X11/05	STATUS-	To disable STO: do not connect
X11/06	STATUS+	To disable STO: do not connect
X11/07	STO 0V	To disable STO: connect to X14/04

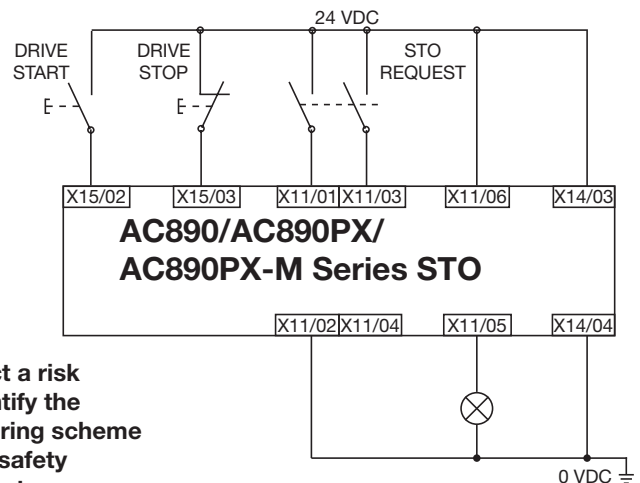

The example wiring diagram shows the minimum connections required to implement STO with the AC890PX-M series AC drives.

Users must conduct a risk assessment to identify the appropriate STO wiring scheme and ensure that all safety requirements are met.



It is the user's responsibility to ensure the safe and correct use of the STO function of the AC890PX-M Series. User's should read and fully understand chapter 6 (Safe Torque Off) of the product user manual. Manual No. HA501299_01

Non-power connectors

Term.	Label	Description
X10/		USB programming port
X12/01	0 V	0 V Reference Supply
X12/02	AIN1	Analogue Input 1
X12/03	AIN2	analogue Input 2
X12/04	AIN3	Analogue Input 3 - Remote setpoint
X12/05	AIN4	Analogue Input 4 - Speed Trim
X12/06	AOUT1	AOUT1 - Speed Feedback
X12/07	AOUT2	AOUT2 - Torque Feedback
X12/08	+10 V	+10 V Reference Supply
X12/09	-10 V	-10 V Reference Supply
X13/01	24 VDC	24 VDC - User Supplied
X13/02	24 VDC	24 VDC- Daisy chain out to next drive
X13/03	0 VDC	0 VDC - Daisy chain out to next drive
X13/04	0 V	0 V -User Supplied
X14/01	DOUT3A	Drive healthy relay output
X14/02	DOUT3B	Drive healthy relay output
X14/03	24 VDC	24 V DC Common supply
X14/04	0 V	0 V Reference

Term.	Label	Description
X15/01	DIN1	Digital Input 1 - (Jog)
X15/02	DIN2	Digital Input 2 - (Run)
x15/03	DIN3	Digital Input 3 - (Stop)
X15/04	DIN4	Digital Input 4 - (Reverse)
X15/05	DIN5	Digital Input 5 - (Unassigned)
X15/06	DIN6	Digital Input 6 - (Unassigned)
X15/07	DIN7	Digital Input 7 - (Unassigned)
X15/08	DINOUT1	Digital In/Out - (Running)
X15/09	DINOUT2	Digital In/Out - (Zero Speed)
X16/01	DOUT4A	Relay output 4
X16/02	DOUT4B	Relay output 4
X16/03	DOUT5A	Relay output 5
X16/04	DOUT5B	Relay output 5
X16/05	DOUT6A	Relay output 6
X16/06	DOUT6B	Relay output 6
X16/08	THERMB	Motor thermistor input B
X16/09	THERMA	Motor thermistor input A

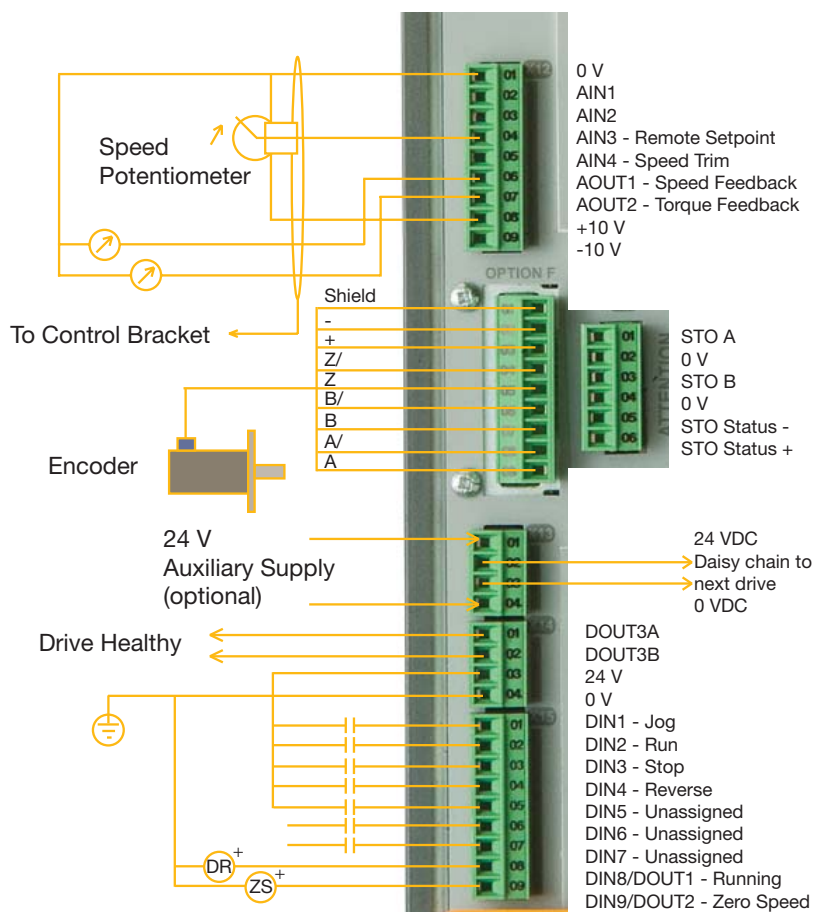

Standard Power Configurations

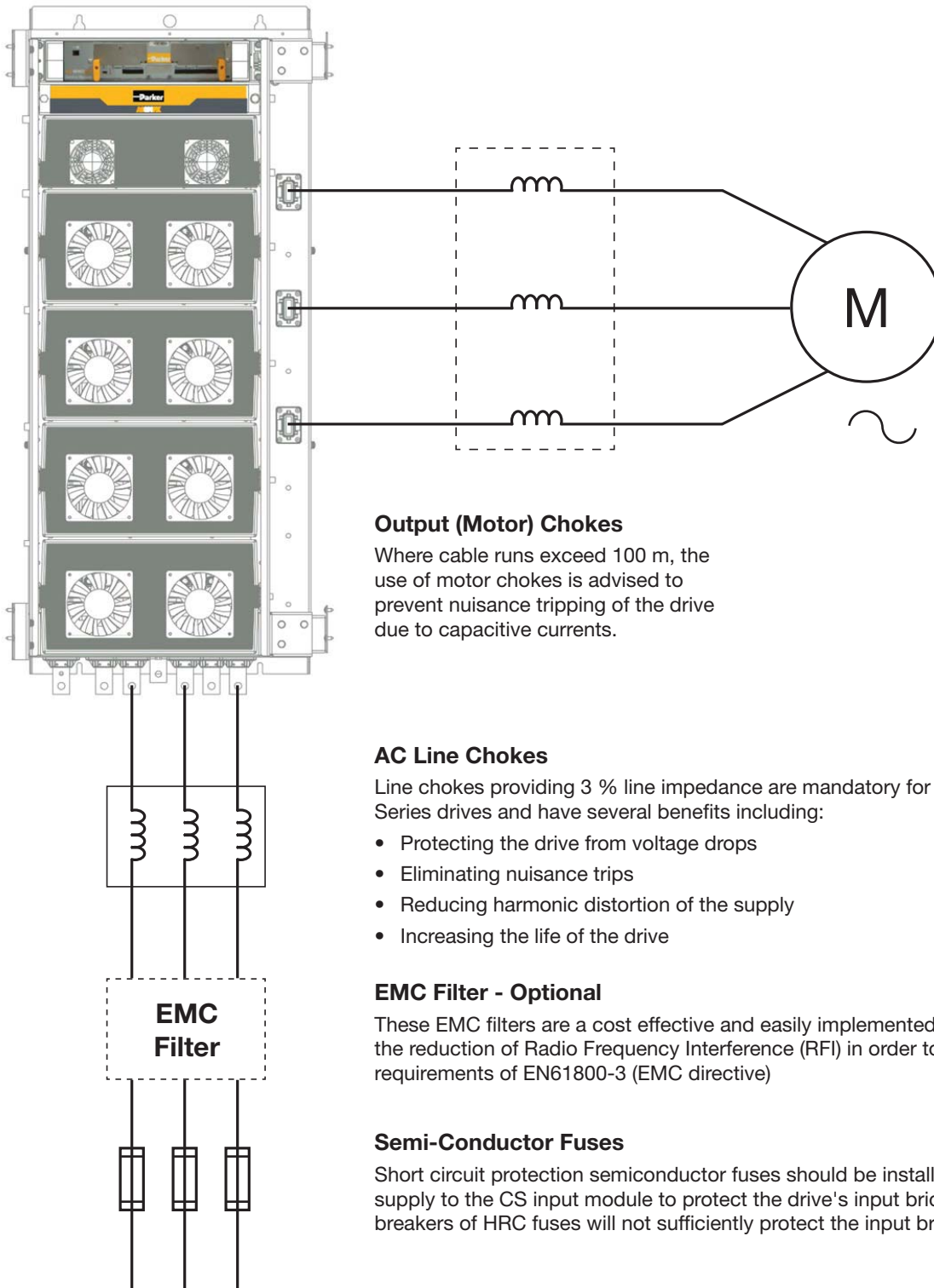

Output (Motor) Chokes

Where cable runs exceed 100 m, the use of motor chokes is advised to prevent nuisance tripping of the drive due to capacitive currents.

AC Line Chokes

Line chokes providing 3 % line impedance are mandatory for the AC890PX-M Series drives and have several benefits including:

- Protecting the drive from voltage drops
- Eliminating nuisance trips
- Reducing harmonic distortion of the supply
- Increasing the life of the drive

EMC Filter - Optional

These EMC filters are a cost effective and easily implemented solution for the reduction of Radio Frequency Interference (RFI) in order to meet the requirements of EN61800-3 (EMC directive)

Semi-Conductor Fuses

Short circuit protection semiconductor fuses should be installed in the 3-phase supply to the CS input module to protect the drive's input bridge. Circuit breakers or HRC fuses will not sufficiently protect the input bridge.

Versatile Power Configurations

The AC890PX-M Series can be configured to operate in a number of different power configuration modes to suit the exact requirements of your application. The modularity of the AC890PX-M Series enables different combinations of PowerPak modules to be easily selected and installed to achieve these schemes without involving significant amounts of pre-engineering work.

Building Blocks

AC890PX-M Series is available in two basic variants which can be combined to create a number of different input power configurations.

Both versions are available in power ratings of 110 kW...400 kW

(SD) Standard Inverter

An AC fed inverter suitable for use with a 400...690 VAC input. This can be used either as a standalone drive in its own right or as the AC input drive in a multi-drive application.

(CD) DC Fed Inverter

A DC fed inverter for use with a 500...1000 VDC input. As with the SD inverter this can be used as a standalone drive where a suitable DC supply is available, or more usually as part of a multi-drive system.

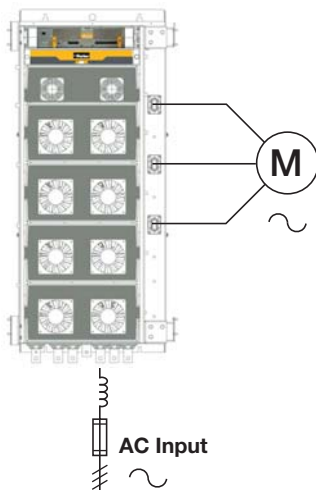

Standard Inverter (SD)

Standard inverter configuration for control of single motor applications in either open or closed loop mode.

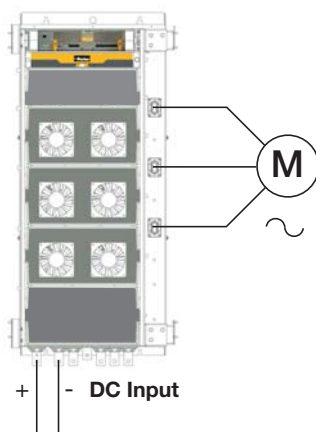

DC Fed Inverter (CD)

DC fed inverter for either single or multi-drive configurations where a suitable DC input supply is available.

Common DC Bus System

Common DC bus system using a standard (SD) inverter with a high power input stage to supply multiple (CD) common bus drives.

- Power range to 400 kW
- 400...700 VAC AC input
- Multi-motor applications
- Common DC bus power sharing

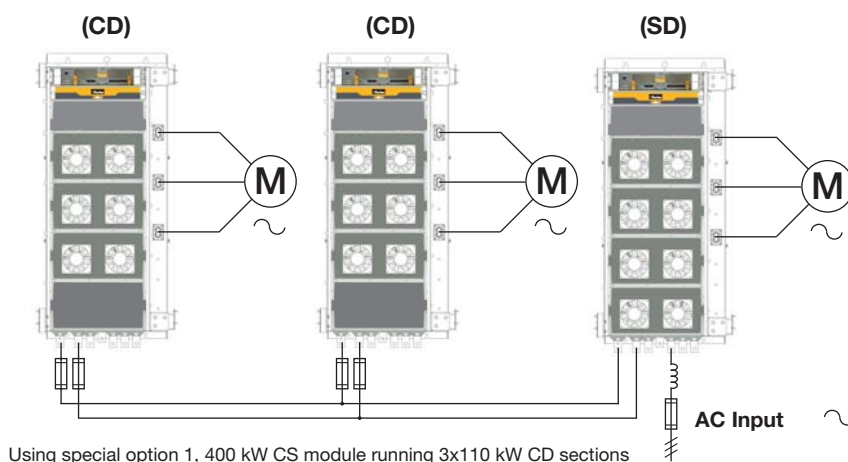

Active Front End (AFE)

Regenerative drive solution for excess system energy and for regenerative applications. With active input for elimination of supply harmonics with unity power factor.

- Power range to 2 MW
- 4Q regenerative system
- Unity power factor

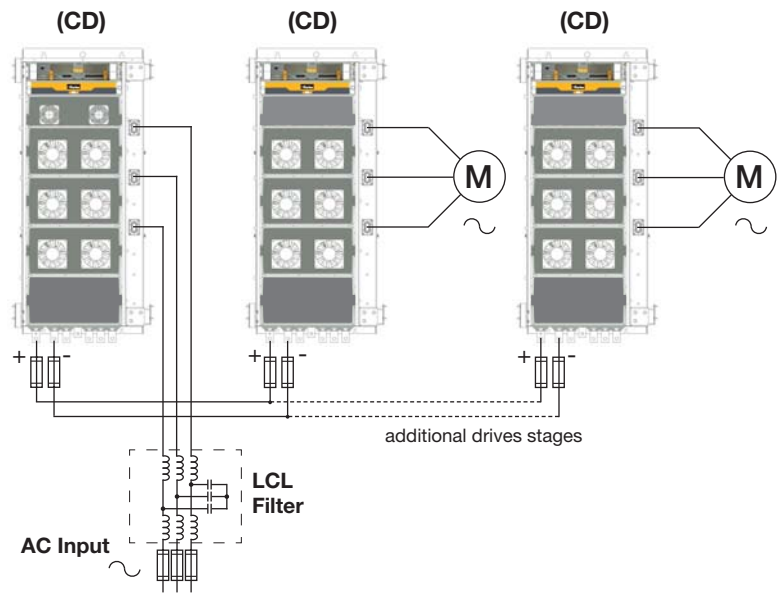

Parallel (AC890XPX)

For power demands greater than 400 kW, offered as pre-built systems in either air or liquid cooled formats for single-, multi-motor, or AFE control.

AC890PX-M Series control module can control up to 3x sections of power modules to achieve power ratings of up to 2000 kW.

- AC or DC input supply
- Motor control or AFE configuration
- Air-cooled to 1200 kW, advanced-cooled to 2 MW

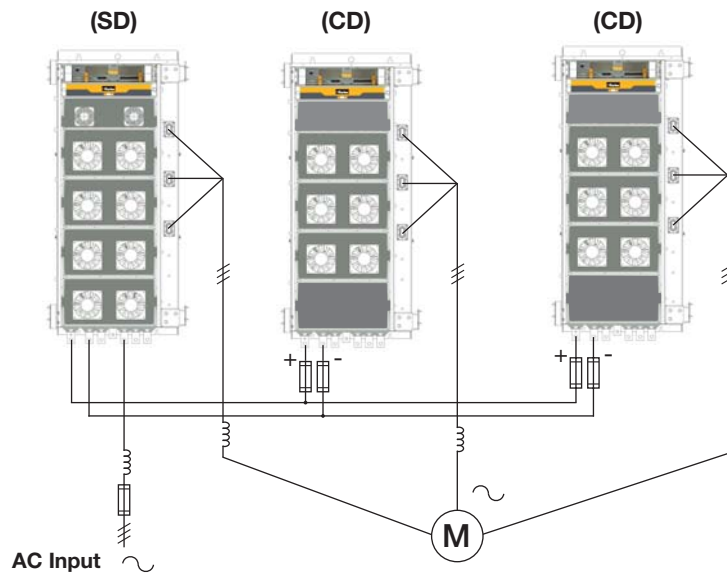

12/18 Pulse Configuration

Offered as a pre-built system, the 12/18 pulse configuration can be used in single-motor applications where power quality and minimal supply harmonic distortion is critical.

- 400..690 VAC AC input
- Power range to 1000 kW
- Minimised input harmonics

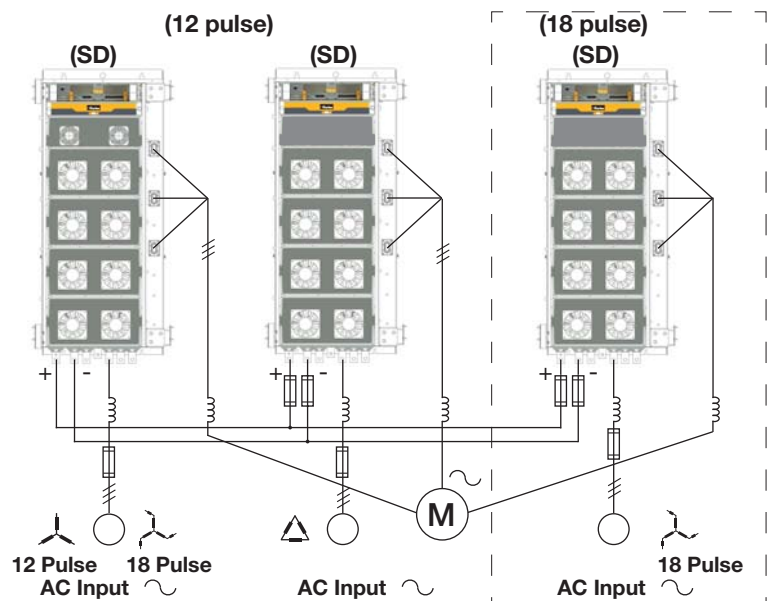

Accessories and Options

Communication Interfaces



8903-IP-00	Ethernet IP communication interface
Supported Protocols	Ethernet IP
Communication Speed	10/100 Mbits/s
Station Address	By Drive System Explorer software via RTNX protocol
Suitable for firmware	Version 3.2+

8903-IM-00	Ethernet Modbus/TCP communication interface
Supported Protocols	Modbus TCP
Communication Speed	10/100 Mbits/s
Station Address	By Drive System Explorer software via RTNX protocol
Suitable for firmware	Version 3.2+

8903-DN-00	DeviceNet communication interface
Supported Protocols	Supports the group 2 only slave subset of the DeviceNet protocol
Communication Speed	125 k, 250 k and 500 kbits/s
Station Address (MACID)	Dip switch or software setting of station address and network speed
Supported Messages	Polled I/O, Cyclic Outputs, Change of State (COS), Explicit Messaging
Suitable for firmware	Version 1.9+

8903-CB-00	CANopen communication interface
Profile	DS402
Communication Speed	20 k, 50 k, 125 k, 250 k, 500 k, 1 Mbits/s selectable by software or DIP switch setting
Station Address	DIP switch or software setting of station address and network speed
Supported Messages	SDO, PDO, NMT, SYNC
Suitable for firmware	Version 1.3+

8903-CN-00	ControlNet communication interface
Communication Speed	Selectable by software or DIP switch setting
Station Address	Software setting of station address
Supported Messages	Polled I/O
Suitable for firmware	Version 1.4+

8903-PB-00	PROFIBUS-DP communication interface
Supported Protocols	PROFIBUS-DP; Demand data and Data exchange
Communication Speed	Up to 12 Mbits/s; selected by the master
Station Address	DIP switch or software setting of station address
Suitable for firmware	Version 1.4+

8903-FA-00	Firewire IEEE 1394 communication interface
Communication Speed	Up to 400 MBaud
Communication Supported	Peer-to-peer communication between drives via IEEE 1394 standard
Suitable for firmware	Version 3.2+



Communication Interfaces

8903-PN-00	PROFINET I/O communication interface
Supported Protocols	PROFINET I/O Real-Time (RT) Protocol
Communication Speed	100 Mbits/s
Station Address	Software setting of station address via DSE
Suitable for firmware	Version 3.3+
8903-SP-00	CAN peer to peer communication interface
Supported Protocols	Peer to peer data exchange with other drives
Communication Speed	Up to 1 Mbits/s selectable by DIP switch
Station Address	Selected by DIP switch setting
Suitable for firmware	Version 3.3+
8903-CT-00	EtherCAT communication interface
Supported Protocols	CANopen over EtherCAT (CoE) DS301 compliant
Communication Speed	100 Mbits/s
Suitable for firmware	Version 3.7+
8903-RS-00	RS485 / Modbus communication interface
Supported Protocols	Modbus RTU only
Communication Speed	1200 to 115200 bits/s
Station Address	Selectable via software
Suitable for firmware	Version 3.7+



Feedback Cards

Incremental Quadrature Encoder Card 8902-EQ

8902-EQ-00-00	Optional HTTL Incremental Encoder
Maximum pulse rate	250 kHz (differential) 200 kHz (single ended)
Receiver current	≤10 mA per channel
Input Format	Two differential channels in quadrature (Clock/direction or clock only)
Input Voltage	±30 V (differential), 0...30 V (single-ended)
Input Voltage Differential	±30 V maximum
Input Voltage Threshold dip switch settings	3 V ±1 V (differential) 8 V ±1 V (single-ended)
Encoder Power Supply	Maximum load 200 mA or 2 W



Description

The HTTL 8902-EQ speed feedback option allows incremental encoders to be connected directly to the drive to provide highly accurate speed feedback measurement. Supplies variable voltage isolated encoder power supply.

Resolver Feedback Card 8902-RE

8902-RE-00-00	Optional Resolver feedback card
Maximum Speed	Up to 50 000 min ⁻¹ (with 2 pole resolver)
Carrier Output Signal	7 V _{rms} , 8 kHz
Maximum Carrier Supply	70 mArms
Maximum Input Voltage	±12 V _{peak}
Accuracy	<5 minutes
Resolution	Equivalent to 16 bits in one revolution of resolver
Inputs	Differential inputs Z _{in} ~2 kΩ
Maximum Input Voltage	12 V _{peak}



Description

The 8902-RE resolver speed feedback option allows the resolver to be connected directly to the drive to provide highly accurate speed feedback measurement. Contains a carrier output signal to power the resolver.

Feedback Cards

SinCos® EnDat2.1 Feedback Card 8902-E1

8902-E1-00-00	Optional SinCos® encoder card
Maximum Pulse Rate	250 kHz
Receiver Impedance	120 Ω
Input Format	two differential 1 V _{pp} signals in quadrature
Encoder Supply	Maximum load 250 mA Adjustable Voltage 5 V/10 V



Description

The SinCos® speed feedback option 8902-E1 allows a 1 V_{pp} SinCos® encoder to be connected directly to the drive to provide highly accurate speed feedback measurement. Decodes Heidenhain EnDat2.1 absolute position encoders and supplies 5 V or 10 V for the encoder.

SinCos® registration position 8902-M1 and 8903-M1

8902-M1-00	Slave SinCos® registration
8903-M1-00	Master SinCos® registration
Maximum Pulse Rate	250 kHz
Receiver Impedance	120 Ω
Input Format	2 differential 1 V _{pp} signals in quadrature
Encoder Supply	250 mA maximum load
Supply Voltage	5 V/10 V adjustable
Terminal Type	Sub-D15 connector
Maximum Cable Length	150 m screened cable
Serial Protocol	EnDat2.1



Description

- The 8903-M1-00 and 8902-M1-00 feedback cards allow operation without external registration position, thanks to the connection of the encoder to the drive. They provide highly accurate speed feedback measurement and registration. Nevertheless registration applications are best achieved when both cards are used.
- Interpolates each encoder line with 11-bit accuracy giving 4 million counts/rev. on a 2048 line encoder
- Supplies 5 V or 10 V to the encoder
- Decodes Heidenhain EnDat2.1 absolute position encoders
- Isolated digital inputs that can be used either for general purpose inputs, or for inputs from registration mark sensor (8903-M1 only)
- 3 non-isolated digital outputs that can be either for general purpose outputs or for synthesizing an encoder output (8903-M1 only)

Approved Encoders

	1 V _{pp}	EnDat2.1	Single turn ABS	Multi-turn ABS
Heidenhain:				
ECN113	√	√		√
ECN1113	√	√	√	
EQN425	√			
ECN413				
ERN480				
Stegmann:				
HG660 AKR (xxxx)S	√			
HG660 DKR (xxxx)S	√			
Hengstler:				
RIS58-H				

Input and Output Cards

Auxiliary digital input (8903-M1... only)

Low Logic Level	0 V to 5 V relative to X63 pin 5
High Logic Level	15 V to 26 V relative to X63 pin 5
Maximum Input Voltage	30 V relative to X63 pin 5
Input Current	Low logic level <1 mA High logic level >3 mA, <10 mA Typical input at 24 V: 7 mA
Isolation withstand relative to drive chassis	30 V
Input Safety Category	SELV
Terminal Type	6-way pluggable 3.5 mm terminal block
Maximum Cable Length	150 m screened cable is recommended for all lengths, but essential if over 30 m in order to comply with EMC regulations

Auxiliary digital outputs (8903-M1... only)

Input Voltage (VS)	5 V to 24 V
Maximum Input Voltage	30 V
Maximum Output Current	±100 mA per output
Output Voltage	Low logic level <3 V to 100 mA High logic level >VS – 4 V to 100 mA
Overload and short circuit duration	Indefinite withstand
Max. Output Frequency	250 kHz per output
Terminal Type	8-way pluggable 3.5 mm terminal block
Maximum Cable Length	150 m screened cable is recommended for all lengths, but essential if over 30 m in order to comply with EMC regulations



High Resolution Analogue Input 8903-AI and 8903-EP Encoder Card

8903-AI-00-00	High Resolution Analogue Input Card
8903-EP-00-00	Encoder Card
Maximum pulse rate	250 kHz
Receiver current	≤10 mA per channel
Input Format	Two differential channels in quadrature (Clock/direction or clock only)
Input Voltage	±30 V (differential), 0-30 V (single-ended)
Input Voltage Threshold dip switch settings	3 V ±1 V (differential) 8 V ±1 V (single-ended)
Encoder Power Supply	Maximum output current ±100 mA per output

High Resolution Analogue Input 8903-AI Only

Analogue Input	
Resolution	15 bits + sign bit
Input Voltage Range	±11 V
Input Format	Differential
Input Impedance	100 kΩ
Input Low Pass Filter	3 kHz
Encoder Power Supply	Maximum output current ±100 mA per output

Description

The high resolution Analog Input Option adds a sixth analogue input to the AC890PX-M Modular Chassis drive. This input can be used, as the other inputs, within a configuration or directly as the speed setpoint for a fast response time.

In addition to this Analog Input the 8903/AI option provides an incremental encoder input as well as an incremental encoder output.

The 8903/EP Encoder Option has the same functionalities of the 8903/AI except for the analogue input.

Anciliary Parts

AC Input Chokes

Parker's range of AC input chokes have been especially selected to match the requirements of the Parker AC drive range and are used to reduce the harmonic content of the supply current.

Nominal 400 VAC

Model Number	[kW]	Input Current [A]	Inductance [μ H]	Order code
890PXSA-43215	110	230	100	CO501691U411
890PXSA-43260	132	270	90	CO501691U413
890PXSA-43300	160	340	80	CO501691U416
890PXSA-43420	200	425	55	CO501691U420
890PXSA-43480	250	535	45	CO501691U425
890PXSA-43520	280	600	40	CO501691U428
890PXSA-43580	315	680	35	CO501691U431

For other voltages please contact your local sales office.



Output Chokes

To limit capacitive currents and prevent nuisance tripping in installations with longer cable runs over 100 m, a choke may be fitted to the drives output. This limits the capacitive current and prevents overcurrent trips and excessive temperature rise in the motor. These may be used with 380/460 V and 500/575 VAC drives.

Motor Choke Maximum Current	Order Code
250 A	CO471702U250
320 A	CO471702U320
400 A	CO471702U400
500 A	CO471702U500
600 A	CO471702U600
700 A	CO471702U750



Auxiliary Transformers

1 kVA 30 VAC control transformer for auxiliary power supply requirements.

Supply Voltage	Order Code
400-480 VAC	C0501514
500-690 VAC	C0501515



EMC Filter

A range of custom designed optional EMC (Electromagnetic Compatibility) filters are available for use with Parker SSD Drives product range. They are used to help achieve conformance with the EMC directive BS EN 61800-3:2004 - "Adjustable speed electrical power drive systems - Part 3".



Rating	Order Code
Up to 132 kW	CO467843U340
Up to 315 kW	2-off CO467843U340

AFE 4 Quadrant

In many applications the overall power consumed by the system is less than the sum of power of the installed motors as some motors will be driven electrically while others are coasting, being driven by the momentum of the machine.

For such applications, it is beneficial to connect the drives of all sections of the machine to a common DC bus: the energy-generating sections are then fed into the energy-consuming sections, which reduces the overall energy consumption of the system.



Thanks to the 4 quadrant (4Q) functionality of the AC890PX-M Series, excess energy in the system is returned to the network and not dissipated in the form of heat through braking resistors. The current waveforms are almost sinusoidal, which minimizes network harmonics

Rating	Filter Assembly 110 V fans & control	Filter Assembly 230 V fans & control	L1 (5 %)	L2 (3 %)
Nominal 400 VAC				
Up to 180 kW	LA482468U220	LA482471U220	CO468326U220	CO468325U220
Up to 280 kW	LA482468U315	LA482471U315	CO468326U315	CO468325U315
Up to 315 kW	LA482468U355	LA482471U355	CO468326U355	CO468325U355
Nominal 500 VAC				
Up to 180 kW	LA482469U220	LA482472U220	CO468326U220	CO468325U220
Up to 280 kW	LA482469U315	LA482472U315	CO468326U315	CO468325U315
Up to 315 kW	LA482469U355	LA482472U355	CO468326U355	CO468325U355

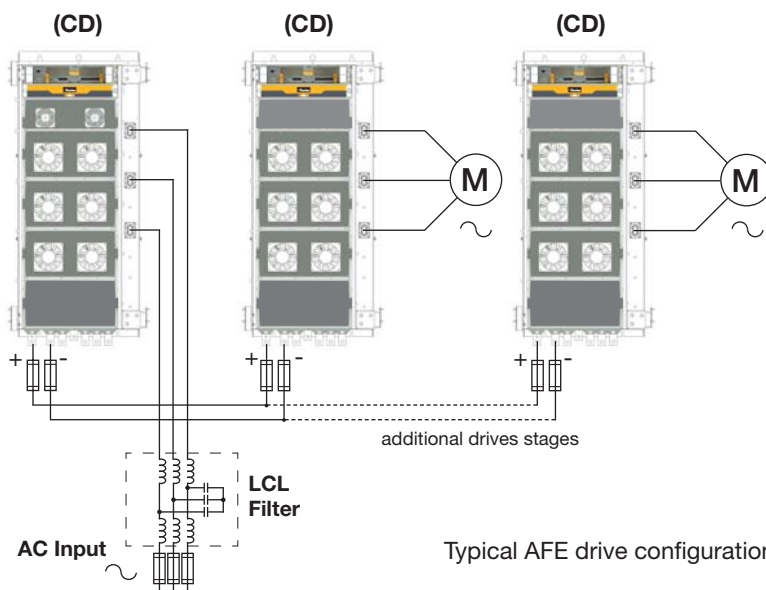

Drive System Explorer (DSE) Software

Description

DSE890 is the programming, monitoring and diagnostic software platform for AC890 and AC890PX-M series variable speed drives. Communication between the drive and PC is via a mini USB port located on the front of the drive.

Thanks to the on-line help, users can achieve the optimum drive configuration without the need to navigate through complicated parameter menus.

Advanced programming is carried out through a set of pre-engineered templates in order to create the required configuration.

It is possible to monitor every parameter of the drive either as a digital value or as a function in the “chart recorder” during normal operation. Creates projects quickly and easily

- Graphical tool based on a block diagram approach
- Integrated digital oscilloscope
- On-line configuration and monitoring
- System identification tool

DSE Lite software is available as a free download from www.parker.com

DSE890 Programming Software

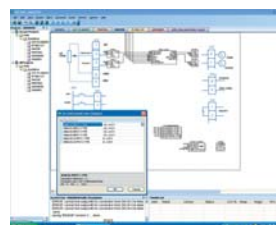
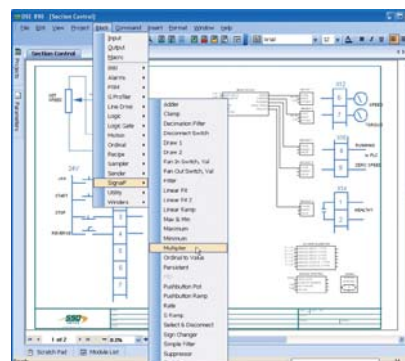

Parameter adjustment and project creation

Product Codes

DSE Lite software (single axis) + USB cable	8906-DSELITE-00
DSE Development software + USB cable	8906-DSEDEV-00
DSE Runtime/Maintenance + USB cable	8906-DSERUN-00
DSD to DSE Development Upgrade + USB cable	8906-DSEDE
DSD Runtime to DSE Runtime Upgrade + USB cable	906-DSERUNUPG-00

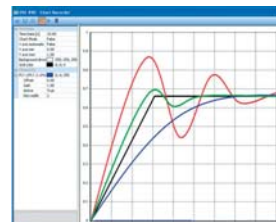

real-time data acquisition oscilloscope

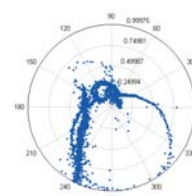
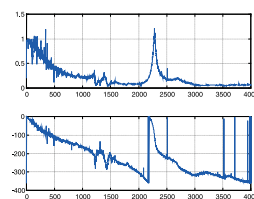

System identification tool

Order Code

AC890PX-M Modular Chassis Drive

	1	2	3		4	5	6		7	8	9		10	11	12	13	14
Order example	890PX	S	A	-	4	3215	M	-	B	0	0	-	1	A	0	0	0

1 Drive family	890PX	High Power Modular AC Drive Series
2 Configuration	S	Standalone Drive (SD)
	C	Common DC Bus Drive (CD)
3 Cooling	A	Air-Cooled
4 Nominal voltage	4	400/460 V Nominal Supply
	6	575 V Nominal Supply
	7	690 V Nominal Supply
5 Power and current ratings (Constant, Variable Torque)	400/460 V Nominal Supply	
	3215	110/132 kW, 150/200 HP
	3260	132/160 kW, 200/250 HP
	3300	160/200 kW, 250/300 HP
	3420	200/250 kW, 300/400 HP
	3480	250/280 kW, 400/500 HP
	3520	280/315 kW, 375/476 HP
	3580	315/400 kW, 500/600 HP
	575 V Nominal Supply	
	3160	112/149 kW, 150/200 HP
	3210	149/187 kW, 200/250 HP
	3260	187/224 kW, 250/300 HP
	3310	224/298 kW, 300/400 HP
	3410	298/373 kW, 400/500 HP
	690 V Nominal Supply	
	3130	110 kW/132 kW, 150/200HP
	3160	132 kW/160 kW, 200/250 HP
	3190	160 kW/200 kW, 250/300 HP
	3230	200 kW/250 kW, 300/400 HP
	3280	250 kW/280 kW, 400/500 HP
	3320	280 kW/315 kW, 375/476 HP
	3340	315 kW/400 kW, 500/600 HP
6 Build Style	M	Modular Chassis Drive
7 Brake	0	Brake not available for CD inverter
	B	Brake fitted as standard to SD inverter

8 Enclosure	0	No Enclosure (Frame M only)
9 Documented special options (0-9)	0	No special option
10 Performance level	1	Advanced
	2	High
11 Supply Frequency	A	50 Hz
	B	60 Hz
12 Feedback Option - Slot F	0	None
	1	SinCos encoder (Endat 2.1)
	3	Incremental quadrature encoder
	5	Resolver
	6	Resolver repeater
	7	Mark registration (Endat 2.1 encoder)
13 Technology Option - Slot A	0	None
	N	CANopen communications
	C	ControlNet communications
	D	DeviceNet communications
	P	Profibus communications
	T	Modbus TCP/IP
	H	Ethernet IP
	F	Profinet
	7	Mark registration (Endat 2.1 encoder)
	S	RS485 communications
	E	Encoder with repeater output
	R	High Resolution Analogue Input
14 Option B	0	Not fitted
	A	Firewire 1394A
	X	CAN peer-to-peer communications
	E	Encoder with repeater output
	R	High Resolution Analogue Input

Packaged Drives Options - Factory Supplied

High Power Packaged AC Drives

AC890PX FASTPACK Drive: 110 - 400 kW

In addition to being supplied in kit form, AC890PX Modular Chassis drives can be supplied as a FASTPACK free-standing drive complete with all necessary ancillary components to enable control of either an AC induction or Permanent Magnet AC motor.

Designed as a simple replacement to star/delta or soft start control of motors, FASTPACK can be configured to deliver complete control in a ready-to-install IP33 or IP54 enclosure.

Control options such as operator keypad, start/stop pushbuttons, emergency-stops and output contactors can all be selected from a list of standard options to meet a host of control requirements from simple motor speed control to more complex applications.



**AC890PX Modular Advanced-Cooled Parallel AC Drive Systems:
500 - 2,000 kW**

With the introduction of an innovative Parker-engineered cooling system, drive systems with increased power outputs can be created with an extremely compact footprint.

The award-winning, advanced cooling design draws from years of Parker experience in refrigeration technology combined with state of the art drive design to produce a truly high-performance AC drive range.

The hermetically sealed system has no compressor, requires no routine maintenance and uses a non-conductive, non-corrosive coolant.



Steel Manufacturing

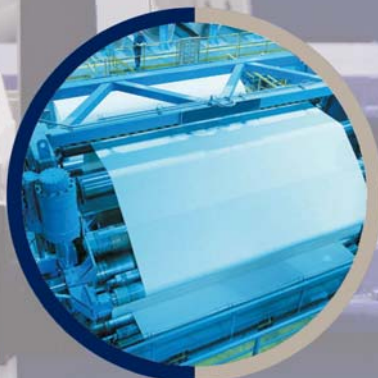

Converting



Power Conversion

Technical Notes

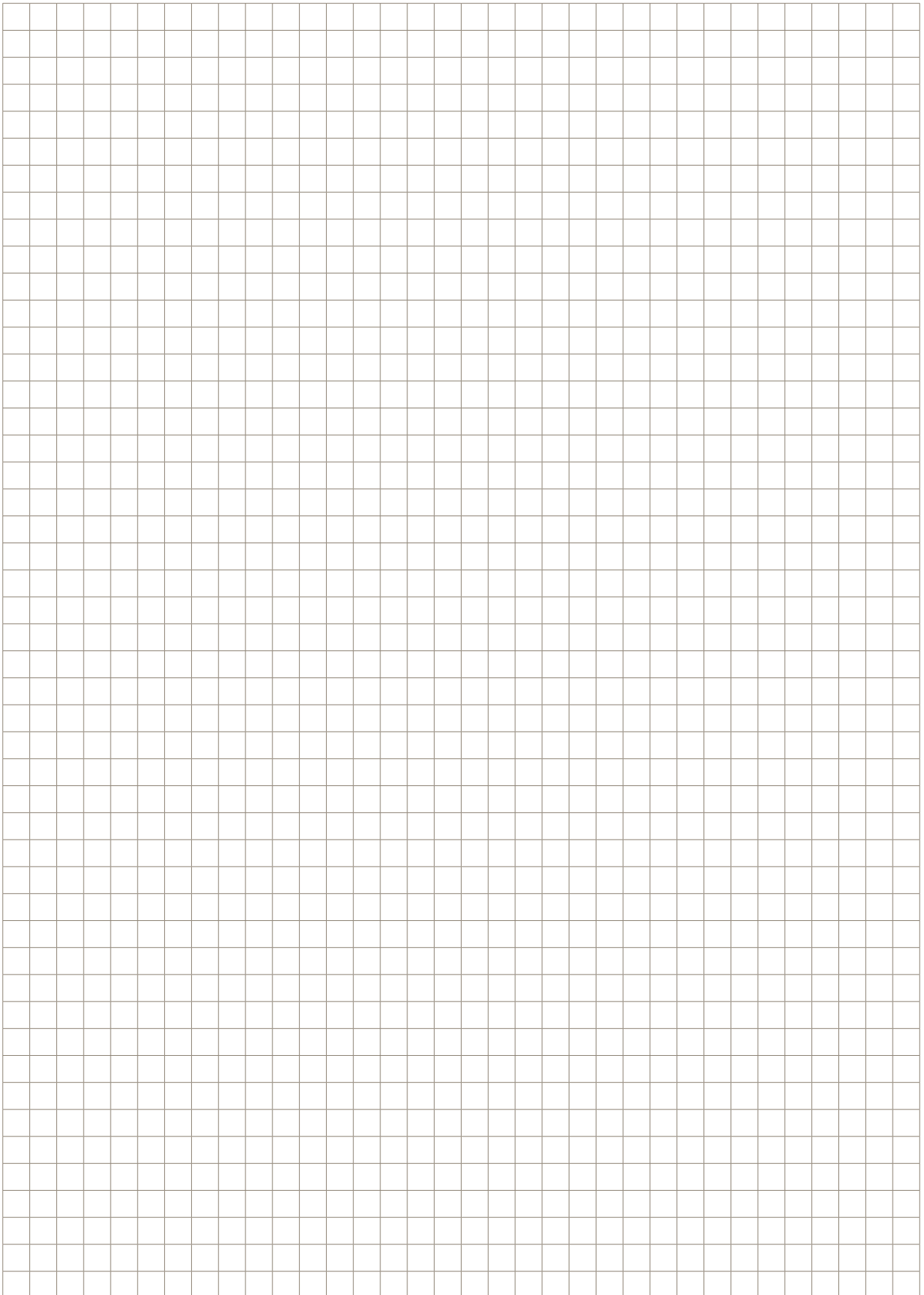

DC Drives

Range Overview 1A - 2,700A

Global DC Drive Solutions to Maximise Flexibility and Increase performance

With 40 years of worldwide application experience, Parker assists its customers in improving productivity and reducing energy consumption with a comprehensive, robust range of DC drives and drive systems. Parker DC drive products are sold, supported and serviced worldwide, with solutions from simple speed control to complex multi-motor coordinated process control. Parker DC drive products are easy to configure and commission, with simple but flexible function block-based configuration tools and connectivity with all major industrial fieldbus networks.



506 / 507 / 508



512C / 514C



5 Series DC Drive

- Centrifugal fans and pumps
- Extruders and mixers
- Small paper converting machines
- Conveyors & packaging machinery
- Winders, reelers and wire drawing machinery

DC590+ Series Digital DC Drive

- Converting machinery
- Plastics processing machinery
- Wire and cable manufacturing
- Automotive test stands
- Extruders

Variable Speed DC Drives

Range Overview 1 - 2700 A

With more than 30 years of worldwide application experience, Parker assists its customers in improving productivity and reducing energy consumption with a comprehensive, robust range of DC drives and drive systems. Parker DC drive products are sold, supported and serviced worldwide, with solutions from simple speed control to complex multi-motor coordinated process control. Parker DC drive products are easy to configure and commission, with simple but flexible function block-based configuration tools and connectivity with all major industrial fieldbus networks.

Digital DC Drives Maximise Flexibility and Functionality

Using the same 32-bit control architecture as our current range of AC drive products, Parker's range of digital DC drives provides the same high level of functionality - and

with its flexibility and performance - as comparable AC drive systems, while simultaneously allowing the user to integrate both AC and DC drive systems in a single machine with the same interface and software.

Retrofit Existing Applications with the Latest Technology

By retrofitting existing DC motor applications with Parker digital DC drives, the user can avoid the cost of replacing an existing functioning, DC motor with a similar AC drive system, while still enjoying the benefits of a flexible control platform and high performance drive.

DC Drives Product Range Overview

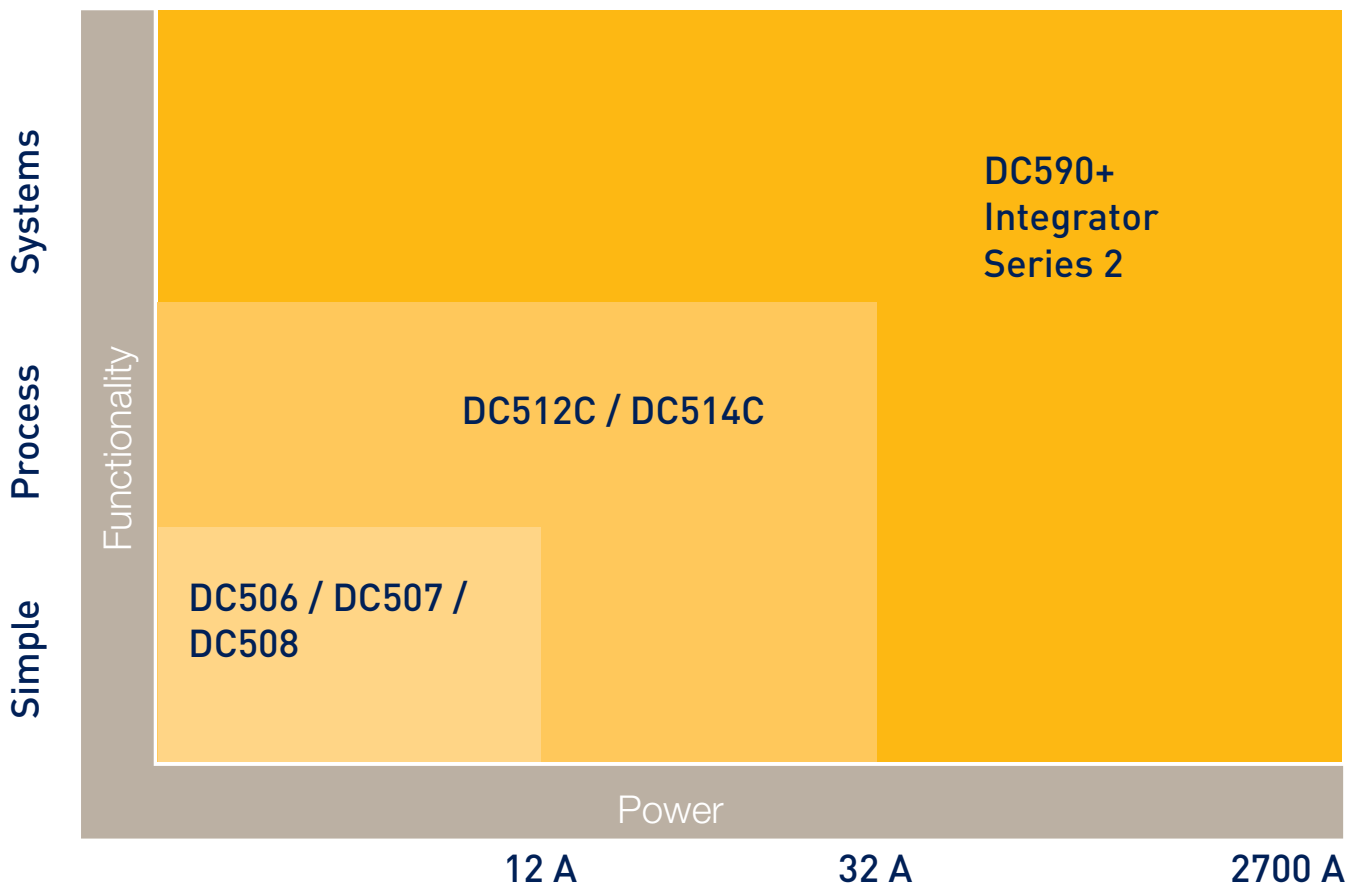

Digital DC Drives Range

DC590+ Integrator Series 2 Digital DC Drive

The DC590+ uses an advanced control platform to provide high levels of flexibility and performance for a wide range of applications. Designed for machine integrators, the DC590+ features function block programming, multiple communications and feedback options and support worldwide. Available as non-regenerative or full four quadrant regenerative. Available from 1-2700 A maximum. Fieldbus options include Profibus-DP, CANopen, Modbus RTU, Ethernet and DeviceNet.

Typical applications include

- Converting machinery
- Plastics processing machinery
- Wire and cable manufacturing
- Automotive test stands

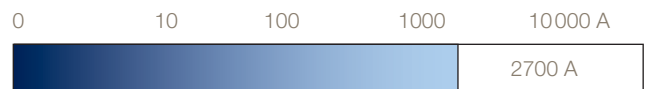

Single Phase Analogue DC Drives Range

Analogue Non-Isolated Converter: 506/507/508

Economical, compact torque and speed control of permanent magnet or shunt wound DC motors. Selectable between 110 VAC or 230 VAC single phase supply. Tachometer or armature voltage feedback, 3, 6, or 12 A armature options.

Typical applications include:

- Conveyors, basic speed control
- Packaging machinery



Two Quadrant Analogue Isolated Converter: 512C

The 512C provides effective torque and speed control of permanent magnet or wound field DC motors. Extremely linear speed and current loops in an isolated package, ideal for single or multiple motor applications up to 32 A, 9 kW.

Typical applications include:

- Centrifugal fans and pumps
- Extruders and mixers
- Small paper converting machines



Four Quadrant Analogue Isolated Converter: 514C

The 514C offers full four quadrant regenerative control of permanent magnet or wound field DC motors. Ideal for applications requiring accurate or rapid deceleration of high inertia loads. Effective for single or multiple motor applications to 32 A, 9 kW.

Typical applications include:

- Machine tool spindles
- Wire drawing machines
- Winders/Reelers



Analogue DC Drives - 506/507/508 Series

Up to 2 kW

Description

The 506, 507 and 508 series drives break new ground in cost-effective DC motor control. Available in 3, 6 or 12 A armature ratings, the feature packed minimum footprint design is ideal for speed or torque control of permanent magnet or shunt wound DC motors fed from single phase supplies.

Typical applications include:

- Conveyors, Basic speed control
- Packaging machinery

Features

- Low cost high featured design
- IP20 protected covers
- Compact footprint and DIN rail mounting
- Selectable 110 VAC or 230 VAC supply
- Selectable tacho or armature voltage feedback

Standards

- CE Marked to EN50178 (Safety, Low Voltage Directive)
- CE Marked to EN61800-3 (EMC Directive) with external filter
- NRTL Listed to US Standard UL508C
- NRTL listed to Canadian standard C22.2#14

Dimensions

Type	A	B	C	Weight [kg]
506	80	105	140	0.59
507	80	105	140	0.59
508	90	105	140	0.70

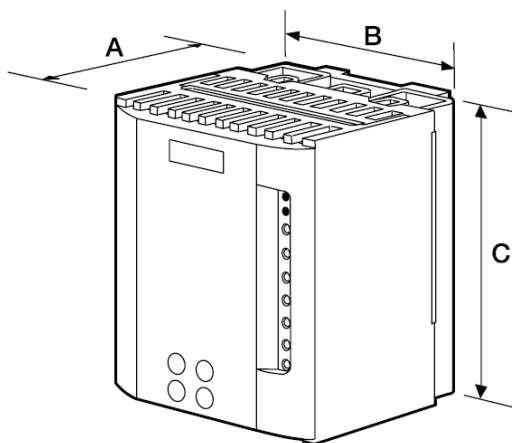

Dimensions [mm]



Technical Characteristics - Overview

Supply voltage	110...120 VAC, or 220...240 VAC ±10 % single phase 50...60 Hz ±5 %
Ambient	0...45 °C, Altitude 1000 m
Installation/diagnostics	
Environment	IP20 Protection
Mounting	DIN rail
Control	Speed or torque
Output	2 A VDC field control
Detection	15 s stall detect
Protection	Electronic overcurrent protection
Signal	Drive healthy and zero speed
Inputs	Main and trim setpoint inputs
Ramps	Independent acceleration and deceleration ramps
Diagnostics	Via LED
Potentiometer adjustments	
Speed	maximum / minimum
Current limit	
Speed stability	
Time	acceleration (1...15 s) deceleration (1...15 s)
IR compensation	
Switch selectable	
Supply voltage	110/120 VAC or 220/240 VAC
Speed Feedback	Tachogenerator / armature voltage feedback
Calibration	Speed and Current

Order Code	Armature Current [ADC]	Supply Voltage [VAC]	Armature Voltage [VDC]	Field Voltage [VDC]
506-00-20-00	0...3	110...120	90	100
	0...3	220...240	180	210
507-00-20-00	0...6	110...120	90	100
	0...6	220...240	180	210
508-00-20-00	0...12	110...120	90	100
	0...12	220...240	180	210

Analogue DC Drives - 512C Series

Up to 9 kW

Description

Isolated control circuitry, a host of user facilities and extremely linear control loop make the 512C ideal for single motor or multi-drive low power applications. Designed for use on single phase supplies, the 512C is suitable for controlling permanent magnet or field wound DC motors in speed or torque control.

Typical applications include:

- Centrifugal fans and pumps
- Extruders and mixers
- Small paper converting machines

Features

- Fully isolated control circuits
- 110 V ... 415 V supply selection by jumpers
- CE marked and EMC compliant
- Multiple input speed and current setpoints
- Zero speed and drive healthy outputs
- Extremely linear control loops

Standards

- CE Marked to EN50178 (Safety, Low Voltage Directive)
- CE Marked to EN61800-3 (EMC Directive) with external filter
- NRTL Listed to US Standard UL508C
- NRTL listed to Canadian standard C22.2#14

Dimensions

Type	A	B	C	D	E	Weight [kg]
512C-04, -08 or -16	160	240	85	148	210	1.5/1.6/1.6
512C-32	160	240	123	148	210	2.9

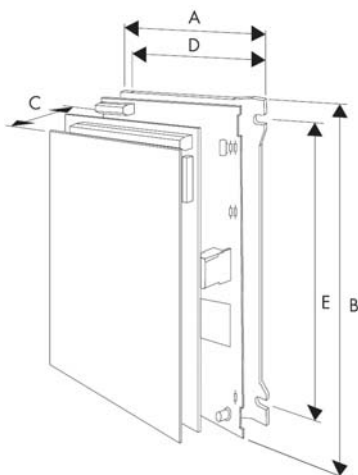

Dimensions [mm]



Technical Characteristics - Overview

Supply Voltage	110...115 V, 220...240 V or 380...415 V ±10 %; 50...60 Hz ±5 %; single phase; selection by switch	
Ambient	0...40°C, Altitude max 1000 m	
Overload	150 % for 60 s	
Installation/diagnostics		
Voltage selection	Jumper selection of supply voltage	
Control	Speed or torque	
Output	3A DC field control	
Diagnostics	Power on, stall detect and overcurrent LEDs	
Protection	Electronic overcurrent protection	
Speed output	Buffered 10 V, 10 mA	
Current output	Buffered 7.5 V, 10 mA	
Ramp output	Buffered (master/slave)	
Reference supply	10 Vcc (10 mA)	
Inputs	Total setpoint Off	
Drive Outputs	Drive Healthy	
Output speed / setpoint	Zero Speed / zero setpoint	
Potentiometer adjustments		
Speed		
Current Limit	maximum / minimum	
Speed stability		
Time	acceleration (1...15 s) deceleration (1...15 s)	
IR Compensation		
Supply Voltage [VAC]	Armature Voltage [VDC]	Field Voltage [VDC]
110	90	100
240	180	210
415	320	360
Order Code	Armature Current [ADC]	
512C-04-00-00	4	
512C-08-00-00	8	
512C-16-00-00	16	
512C-32-00-00	32	

Analogue DC Drives - 514C Series

Up to 9 kW

Description

The regenerative 514C DC thyristor drive offers full four quadrant control of DC motors from single phase supplies. As such it is ideal for applications involving overhauling loads or where rapid and accurate deceleration is required. Together with the non-regenerative 512C they offer the perfect solution for lower power single motor and multi-drive applications.

Typical applications include:

- Machine tool spindles
- Wire drawing machines
- Winders/Reelers

Features

- Four quadrant regenerative control
- 110...500 VAC AC supply selection by jumpers
- CE marked and EMC compliant
- AC power contactor logic and supply
- Many system features
- Extremely linear control loops

User Facilities

- Four quadrant regenerative control
- Separate AC auxiliary supply
- AC supply contactor logic
- Torque or speed control
- Three setpoint and torque limit inputs
- Buffered analogue current output (10 V, 10 mA)
- +10 V and -10 V analogue reference supplies
- +24 V digital reference supply
- Drive healthy output
- Buffered speed & ramp output (10 V, 10 mA)
- Buffered total setpoint output (10 V, 10 mA)
- Zero speed / zero setpoint output

Potentiometer Adjustments

- Maximum speed / Current limit
- Acceleration time and Deceleration time (0...40 s)
- IR Compensation
- Speed loop gain - proportional and integral
- Current gain - proportional and integral
- Zero speed offset or threshold

Standards

- CE Marked to EN50178 (Safety, Low Voltage Directive)
- CE Marked to EN61800-3 (EMC Directive) with external filter
- NRTL Listed to US Standard UL508C
- NRTL listed to Canadian standard C22.2#14



Technical Characteristics - Overview

Supply voltage	110...500 V +10 % user selectable
Auxiliary supply	110/120 or 220/240 V +10 % user selectable Single phase 50...60 Hz +10 %
Ambient	0...40 °C - Altitude: up to 1000 m without derating
Overload	150 % for 60 s

Supply Voltage [VAC]	Armature Voltage [VDC]	Field Voltage [VDC]
110	80	100
240	180	210
415-500	320	360

Order Code	Armature Current [ADC]
514C-04-00-00	4
514C-08-00-00	8
514C-16-00-00	16
514C-32-00-00	32

Dimensions

Type	A	B	C	D	E	Weight [kg]
514C-04, -08	160	240	90	148	210	1.6
514C-16, -32	160	240	130	148	210	3.0

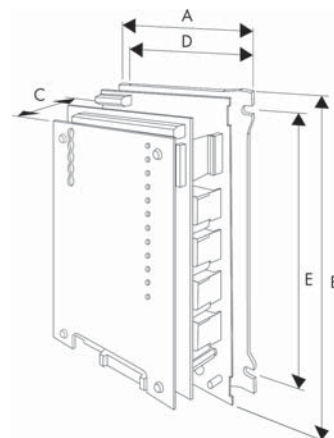

Dimensions [mm]

Variable Speed DC Drives - DC590+ Integrator Series 15 A - 2700 A

Overview

Description

The DC590+ Integrator Series DC drive is the latest development of the range which also includes the AC690+ AC drives. It benefits from 30 years experience of designing and manufacturing drives for process line control with dedicated function blocks which simplify the implementation of applications such as sectional drive reels, winder control etc. The function block capabilities offer unparalleled flexibility in both new installations and retrofit applications. A number of common fieldbus communications options enable connectivity to a wide range of popular control networks allowing the DC590+ to be integrated in larger control systems.

Features

- Ratings up to 2700 A and supply voltages to 690 V
- Internal controlled field supply
Function blocks programming, including open and closed-loop winder control as standard

Standards

The DC590+ series meets the following standards when installed in accordance with the relevant product manual.

CE marked to EN50178 (Safety, Low Voltage Directive)
EN61800-3 (EMC Directive) with integral filters.
External supply capacitors are required up to 110 A for compliance.

- Supply Voltage 220...500 V as standard
- CE marked
- UL an cUL approved up to 830 A

For customers wanting to upgrade from the earlier DC590C analog DC drive, wishing to benefit from the extra functionality and capability of the DC590P, a DC590PX variant is available which enables the new DC590P control section to be used with an existing DC590C power stack. This has the same form factor and terminal arrangements as the earlier DC590C product.



Technical Characteristics - Overview

Power configuration	DC590+ 4 quadrant regenerative; 2 fully controlled 3 phase thyristor bridges DC591+ 2 quadrant; 1 fully controlled 3 phase thyristor bridge
Armature rating (ADC)	Frame 1 15, 35 A Frame 2 40, 70, 110, 165 A Frame 3 180, 270 A Frame 4 380, 500, 725, 830 A Frame 5 1580 A Frame 6 1250, 1600, 1950 A Frame H 1200, 1700, 2200, 2700 A
Overload	15...450 A; 200 % for 10 s 150 % for 30 s - from 700 A: several overload choices are available
Supply voltage (VAC) 50/60 Hz	220...500 V ($\pm 10\%$) Frame 1...5 110...220 V ($\pm 10\%$) Option Frame 1...5 500...600 V ($\pm 10\%$) Option Frame 4...5 380...600 V ($\pm 10\%$) Frame 6 380...690 V ($\pm 10\%$) Frame 6 500...690 V ($\pm 10\%$) Frame H
Field current max	4 A Frame 1 10 A Frame 2 and 3 30 A Frame 4 and 5 60 A Frame H
Field voltage max	$V_{field} = V_{AC} \times 0.82$
Operating Environment	
Operating temperature	0...45 °C (15...165 A) 0...35 °C (180...270 A) 0...40 °C (current ≥ 1200 A) derate by 1 %/°C up to 55 °C max
Altitude	500 m above sea level Derate by 1 %/200 m above 500 m to 5000 m max

Next Generation Technology

Building upon the highly successful DC590+ drive used in thousands of applications world-wide, the DC590+ Integrator drive takes DC motor control to the next level. With its state-of-the-art advanced 32-bit control architecture, the DC590+ drive delivers highly functional and flexible control suited to a whole host of industrial applications.

Typical Applications

- **Converting machinery**
- **Plastics and rubber processing machinery**
- **Wire and cable**
- **Material handling systems**
- **Automotive**

Function Block Programming

Function Block Programming is a tremendously flexible control structure that allows an almost infinite combination of user functions to be realised with ease. Each control function (an input, output, process PID for example) is represented as a software block that can be freely interconnected to all other blocks to provide any desired action.

The drive is despatched with the function blocks pre-configured as a standard DC drive so you can operate it straight from the box without further adjustments. Alternatively you can pick pre-defined Macros or even create your own control strategy, often alleviating the need for an external PLC and therefore reducing cost. Feedback Options

The DC590+ has a range of interface options which are compatible with the most common feedback devices enabling simple motor control through to the most sophisticated multi-motor system. Armature voltage feedback is standard without the need for any interface option.

- **Analogue tachogenerator**
- **Encoder**
- **Optical fibre microtach encoder**

Interface Options

Designed with connectivity in mind, the DC590+ has a number of communications and I/O options that allow the drive to take control of the application, or be integrated into a larger system. When combined with function programming, custom functions and control can be easily created offering the user a highly flexible and versatile platform for DC motor control.

Programming/ Operator Controls

Featuring an intuitive menu structure, the ergonomically designed operator panel allows quick and easy access to all parameters and functions of the drive via a bright, easy to read backlit display and tactile keypad. Additionally, it provides local control of start/stop, speed demand and rotation direction to greatly assist with machine commissioning.

- **Multi-Lingual alpha-numeric display**
- **Customised parameter values and legends**
- **On drive or remote mounting**
- **Local control of start/stop, speed and direction**
- **Quick set-up menu**

Connectivity

Whatever the complexity of your control scheme, the DC590+ has the interface to suit. As standard there's enough analogue and digital I/O for the most complex applications. Alternatively, add the relevant "technology box" for immediate access to serial communications and Fieldbus networks. The DC590+ has been designed to fit seamlessly, and without compromise, into any control environment.

Analogue/Digital Control

- 5 Analogue Inputs (12bit + sign)
- 3 Analogue Outputs
- 9 Digital Inputs
- 3 Digital Outputs

Serial Communications and Fieldbus Options

- PROFIBUS
- CANopen
- Devicenet
- RS422/RS485
- ControlNet
- Ei Bisynch
- Lonworks
- EtherNet
- Modbus



6901 Programming/ Operator Controls

Features and Benefits

Easy to use operator controls

- Detailed diagnostics
- Multi-language display

Advanced autotuning

Standard open fieldbuses



Configurable input-output terminal blocks

- 5 analogue inputs
- 3 analogue outputs
- 9 digital inputs
- 3 digital outputs



Macro function blocks

- Open-loop winder control
- Winder control - loadcell/dancer
- Section control
- Maths functions
- Embedded controller functions

Worldwide product support

The DC590+ DC Drive is available with full application and service support in over fifty countries worldwide. So wherever you are, you can be confident of full back up and support.



Rapid Commissioning, optimal control performance and easy maintenance

With its self-tuning algorithm, the DC590+ can be configured and commissioned within minutes, without turning the motor and without the need for high levels of engineering know-how. The operator interface allows easy monitoring of machine operation and simplifies maintenance.

Easy integration into existing control networks

The DC590+ has a wide choice of common industry fieldbus communication options allowing seamless integration into existing factory control networks.

Interfacing with existing external control equipment (Dancer, gauge, etc...)

A number of input / output options gives the DC590+ the flexibility needed for integration into any variable speed system. Combined with its embedded automation functions, its input-output configurations can in many instances remove the need for an external PLC.

Years of applications expertise at your service

The DC590+ macro function blocks are the result of over 30 years of experience gained by Parker SSD of installing drives in variable speed and sectional drive systems. This unique application experience is included in the drive in the form of dedicated function blocks at no extra cost, thereby reducing the design costs of your machinery.

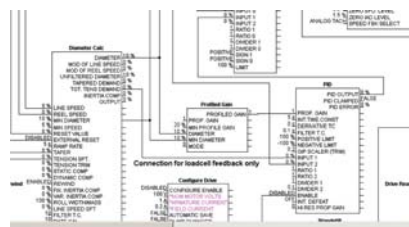

Technical characteristics

Electrical characteristics

Voltage	Output current [A]		Field current max [A]	Frame	Order code ¹
	Continuous 100 %	Overload			
	without overload	150 % x 30 s 200 % x 10 s			
110 V - 220 V	15	15	4	1	590P-2321501...
	35	35	4	1	590P-2323501...
	40	40	1	2	590P-2324002...
	70	70	10	2	590P-2327002...
	110	110	10	2	590P-2331102...
	165	165	10	2	590P-2331652...
	180	180	10	3	590P-2331803...
	270	270	10	3	590P-2332703...
	420	380	30	4	590P-2333804...
	550	500	30	4	590P-2335004...
	800	725	30	4	590P-2337254...
	910	830	30	4	590P-2338304...
1740	1580	30	5	590P-2341585...	
220 V - 500 V	15	15	4	1	590P-5321501...
	35	35	4	1	590P-5323501...
	40	40	10	2	590P-5324002...
	70	70	10	2	590P-5327002...
	110	110	10	2	590P-5331102...
	165	165	10	2	590P-5331652...
	180	180	10	3	590P-5331803...
	270	270	10	3	590P-5332703...
	420	380	30	4	590P-5333804...
	550	500	30	4	590P-5335004...
	800	725	30	4	590P-5337254...
	910	830	30	4	590P-5338304...
	1200	1050	60	H	590P-534120H...
	1350	1250	60	6	590P-5341256...
	1700	1450	60	H	590P-534170H...
	1740	1580	30	5	590P-5341585...
	1750	1600	60	6	590P-5341606...
	2150	1950	60	6	590P-5341956...
2200	2000	60	H	590P-534220H...	
2700	2400	60	H	590P-534270H...	
500 V - 600 V	420	380	30	4	590P-6333804...
	550	500	30	4	590P-6335004...
	800	725	30	4	590P-6337254...
	910	830	30	4	590P-6338304...
	1740	1580	30	5	590P-6341585...
500 V - 690 V	1200	1050	60	H	590P-734120H...
	1350	1250	60	6	590P-7341256...
	1700	1450	60	H	590P-734170H...
	1750	1600	60	6	590P-7341606...
	1950	1850	60	6	590P-7341956...
	2200	2000	60	H	590P-734220H...
2700	2400	60	H	590P-734270H...	

⁽¹⁾ The references are for 4Q drives
 For 2Q drives, replace "590P" for "591P"

Technical Data

Protection	High energy MOV's Heatsink overtemperature Instantaneous overcurrent Thyristor trigger failure Inverse time overcurrent Interline snubber network Field Failure Zero speed detection Speed feedback failure Stall protection Motor overtemperature
Inputs/Outputs	
Analogue inputs	(5 Total - 1 x 12 bit plus sign, 4 x 10 bit plus sign) 1 - Speed demand setpoint (-10/0/+10 V) 4 - Configurable
Analogue outputs	(3 Total - 10 bit) 1 - Armature current output (-10/0/+10 V or 0-10 V) 2 - Configurable
Digital inputs	(9 Total - 24 V, max 15 mA) 1 - Program stop 1 - Coast stop 1 - External stop 1 - Start/Run 5 - Configurable
Digital outputs	(3 Total - 24 V (max 30 V) 100 mA) 3 - Configurable
Reference supplies	1 - +10 VDC 1 - -10 VDC 1 - +24 VDC

Dimensions

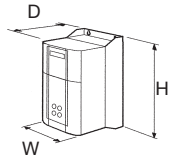

Frame 1/2

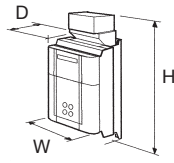

Frame 3

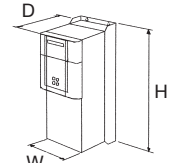

Frame 4

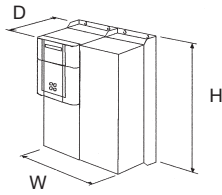

Frame 5

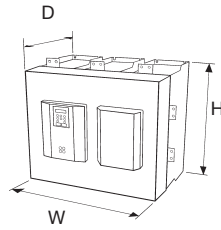

Frame 6

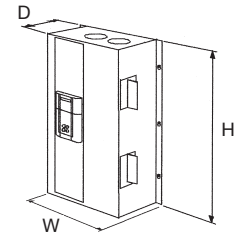

Frame H

Current [A]	Frame	Dimensions [mm]			Weight [kg]
		W	H	D	
15/35	1	200	375	220	6.4
40/165	2	200	434	292	10.5
180/270	3	250	485	234	20
380/500	4	253	700	358	32
725/830					44
1580	5	506	700	358	90
1250/1950	6 2Q	686	715	378	95
	6 4Q				110
1200/1700	H 2Q	850	1406	417	270
2200/2700	H 4Q	850	956	417	160

Overview of Frames

Frames 1 and 2

1	Main drive assembly
2	Terminal cover
3	Terminal cover retaining screws
4	Blank cover
5	6901 keypad (optional)
6	COMMS technology box (optional)
7	Speed feedback technology card (optional)
8	Gland plate
9	Power terminal shield
10	Power terminals
11	Control terminals
12	Earthing points
13	Keypad port
14	RS232 programming port
15	Auxiliary power, external contactor and isolated thermistor terminals

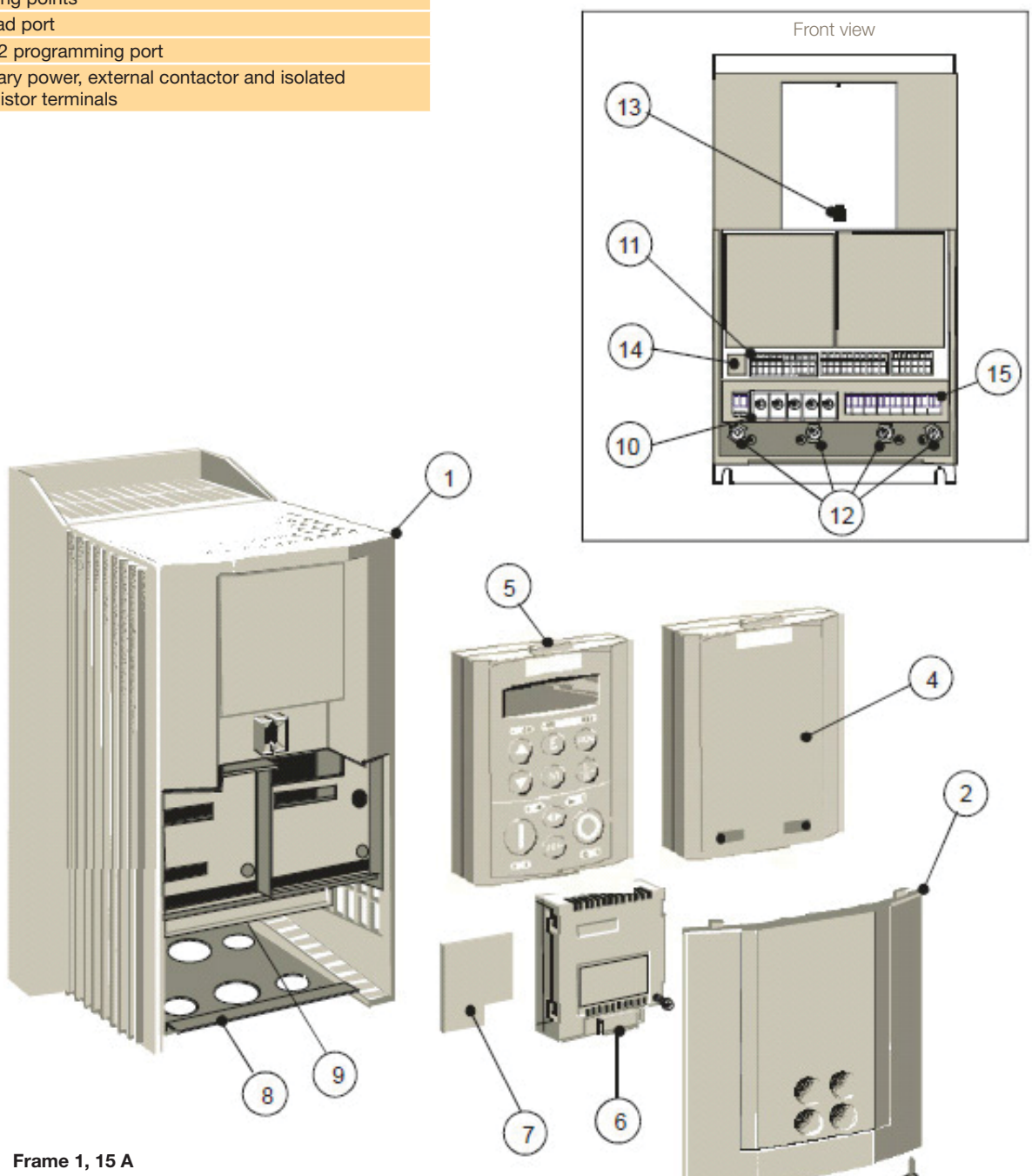

Frame 1, 15 A

Overview of Frame 3

1	Main drive assembly
2	Door assembly
3	Field wiring terminals
4	Busbars - main power input
5	Busbars - main power output
6	IP20 Top cover
7	IP20 Fan housing (where fitted)

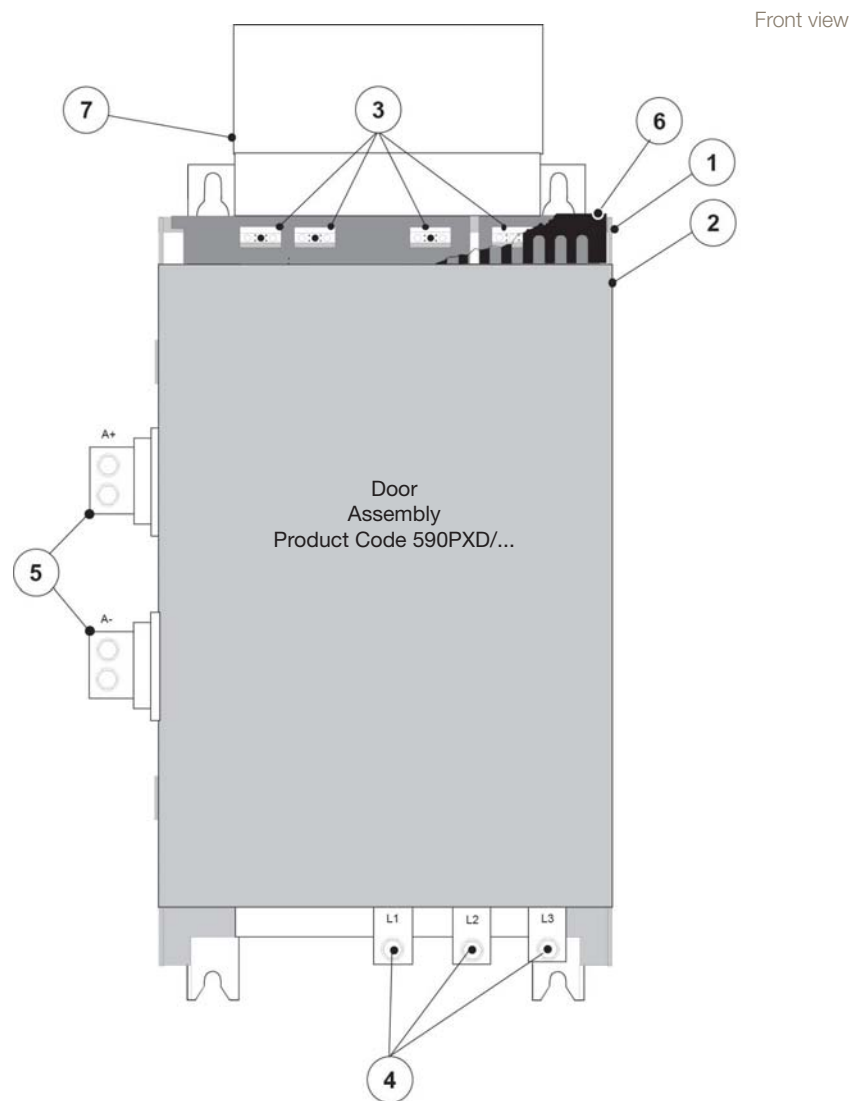

Overview of Frames 4 and 5

1	Main drive assembly
2	Standard door assembly
3	Motor field terminals
4	Busbars - main power input
5	Busbars - main power output
6	Auxiliary supply, contactor and motor thermistor terminals
7	Frame 4 external vent (where fitted)
8	Contactor control select
9	Frame 5 External vent (where fitted)
10	Terminal cover (frame 5)

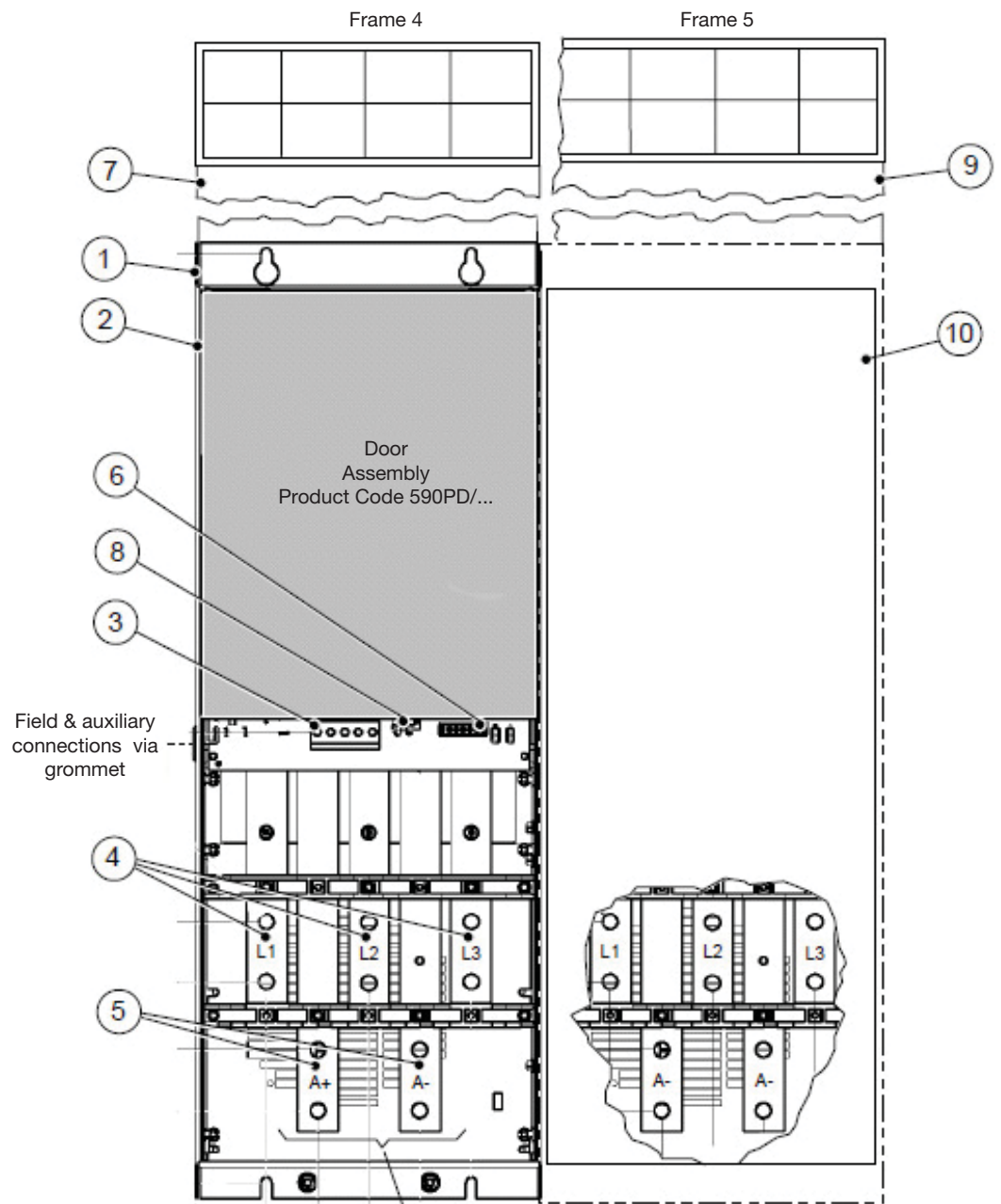

When Frame 5, both terminals are for A+ connections

Overview of Frame 6

1	Phase assemblies - L1, L2, L3
2	Fishplate
3	Control panel assembly
4	Front cover
5	Standard door assembly
6	Field controller
7	Busbars - main power input
8	Busbars - main power output

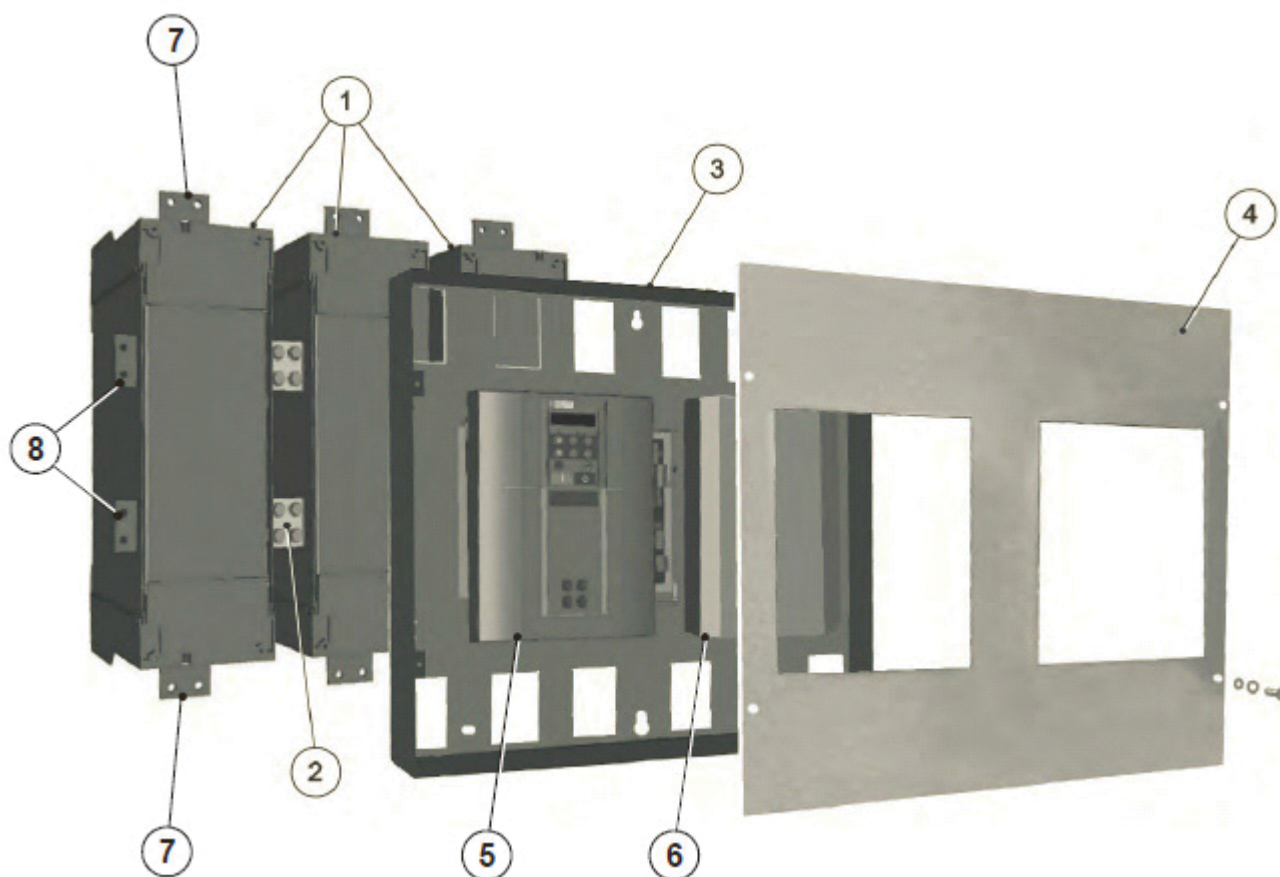

External Stack Controller - DC598+, DC599+ Series

The economical solution for retrofit applications

When upgrading machines equipped with older high power DC drives, the most cost-effective and quickest way is often to reuse the existing thyristor power stack, which in most cases will be in perfect working order. To preserve your investment, Parker SSD Drives has developed a DC598+ / DC599+ power stack controller offer specially aimed at retrofit applications and based on the DC590+ controller.

Available in 2 versions, the DC599+ two quadrant non-regenerative and DC598+ four quadrant full-regenerative versions, can be used to drive the power stacks of existing DC drives manufactured by Parker SSD or other manufacturers, delivering the benefits of the recent technological innovations of the DC590+ Series drive.

The DC598+ and DC599+ offer the ability to upgrade your equipment quickly and easily and integrates with your existing control equipment or SCADA package. The DC598+ and DC599+ retrofit solutions are recommended for currents above 800 A.

Benefits

- Reuse existing DC power stacks
- Connectivity over standard common fieldbuses (Including PROFIBUS, EtherNet, DeviceNet, CANopen)
- Easy to use operator interface
- Flexible common Integrator Series programming environment
- Suitable for currents up to 2700 A

The DC598/9+ provides the following:

- Thyristor firing signals
- Thyristor firing pulse transformers
- AC current transformer feedback rectification and scaling
- Armature voltage feedback interface
- Coding and phase rotation interface
- Mains present monitoring
- Heatsink over-temperature input
- Field power modules and input/output terminals
- Field current monitoring and scaling
- All standard DC590+ I/O terminals



Technical Characteristics

Supply Voltage	110...240 VAC ±10 % 220...500 VAC ±10 % 380...690 VAC ±10 % 3 ph coding or 1 ph power
Supply Frequency	50/60 Hz ±10 %
Output Field Current	60 ADC naturally cooled - 120 ADC force cooled (1 x Field Current DC value) Amps 1 ph. AC Nominal 3 ph AC
Field Output Voltage	(0.9 x 1 ph Supply Voltage) VDC
Total Losses	(3 x idc out) Watts.
Auxiliary Supply	110...240 VAC ±10 % 1 ph - Naturally cooled 110...120 VAC ±10 % 1 ph - Force cooled 115 V fan 220...240 VAC ±10 % 1ph - Force cooled 230 V fan
Auxiliary Supply Current	SMPS Quiescent Current = 500 mA 115 VAC or 250 mA 230 VAC ie 50 VA. Fan current - 270 mA @115 VAC or 135 mA @230 VAC
Auxiliary Supply Fuse	3 A
Operating Temp.	0...+45 °C
Storage Temp.	-25...+55 °C
Shipping Temp.	-25...+70 °C
Enclosure Rating	IP20
Altitude Rating	Maximum Altitude 500 m De-rate the output at 1 % per 200 m
Humidity	Maximum 85 % relative humidity at 45 % non-condensing
Atmosphere	Non flammable, non-corrosive and dust free
Climatic	Class 3k3 as defined by EN60721-3-3 (1995)

Accessories and Options

Overview

Options	Fitting	Order Reference
Operator Keypad		
DC590+ keypad (removable)	Option	6901-00-G
Advanced operator keypad (removeable)		6911-01-00-G
Remote mounting kit		6052/00
Communication Cards		
EtherNet Modbus/TCP and EtherNet IP	Option	6055-ETH-00
ControlNet		6055-CNET-00
Modbus Plus		6055-MBP-00
DeviceNet		6055-DNET-00
RS485 / Modbus		6055-EI00-00
PROFIBUS-DP		6055-PROF-00
CANopen DS402		6055-CAN-00
LonWorks		6055-LON-00
Speed Feedback Cards		
Wire-ended encoder Card	Option	AH387775U001
Analogue Tacho		AH500935U001
Drive Doors		
Door for frames 3 & H (with additional motor thermistor terminals)	Standard	590PXD-0010-UK
Door for Frames 4 & 5		590PD-0010-UK

Communication Cards

The communication cards allow the DC590+ to be connected to the most common industry standard fieldbuses.

Features

- Communication cards can be factory fitted or purchased separately for fitting on-site
- Dimensions HxWxD:
127 mmx76.2 mmx25.4 mm
- LED indication of network and card status

EtherNet Communications Interface	
Order Code: 6055-ETH-00	
Supported Protocols	Modbus/TCP and EtherNet IP
Communication Speed	10/100 M bits/s
Station Address	Selectable via switch or Internet Explorer
Suitable for	DC590+ version 7.1+

ControlNet Communications Interface	
Order Code: 6055-CNET-00	
Supported Messages	Polled I/O
Station Address	Selectable via software
Suitable for	DC590+ version 5.17+

DeviceNet Communications Interface	
Order Code: 6055-DNET-00	
Supported Protocols	DeviceNet Drive Profile – Group 2 slave only
Station Address	DeviceNet Drive Profile – Group 2 slave only
Suitable for	DC590+ version 5.x+

Modbus Plus Communications Interface	
Order Code: 6055-MBP-00	
Supported Protocols	Modbus Plus
Cabling	RS485 2 or 4 wire
Communication Speed	1 M bits/s
Station Address	Selectable via software
Suitable for	DC590+ version 7.1+

CANopen Communications Interface	
Order Code: 6055-CAN-00	
Profile	DS402
Supported Messages	SDO, PDO, NMT, SYNC
Communication Speed	20 k, 50 k, 125 k, 250 k, 500 k, 1 M bits/s selectable
Station Address	Selectable via Switch
Suitable for	DC590+ version 5.x+

PROFIBUS-DP Communications Interface	
Order Code: 6055-PROF-00	
Supported Protocols	PROFIBUS-DP
Communication Speed	Automatically detected
Station Address	Selectable via software
Suitable for	DC590+ version 5.x+

RS485/Modbus Communications Interface	
Order Code: 6055-EI-00	
Supported Protocols	Modbus RTU, EI Bisynch ASCII
Cabling	RS485 2 or 4 wire
Communication Speed	300 to 115200 bits/s
Station Address	Selectable via software
Suitable for	DC590+ version 5.17+

Encoder feedback card

Description

The encoder feedback card allows an incremental encoder to be fitted to the drive to provide accurate measurement of motor speed. The card also provides the encoder power supply.

Specifications

Maximum input frequency	100 kHz
Receiver current consumption	10 mA per channel
Input format	2 channel differential and quadrature
Differential input voltage	Minimum 3.5 V
Encoder power output	+5 V to 24 V adjustable (AH387775U001)
Power supply rating	2 W maximum
Power supply load	1.4 x output power
Terminal size	16 AWG maximum
Tightening torque	0.4 Nm

Order Codes

Order Code	Description
AH387775U001	Encoder Card - Adjustable supply
AH387775U005	Encoder Card + 5 VDC
AH387775U012	Encoder Card + 12 VDC
AH387775U015	Encoder Card + 15 VDC
AH387775U024	Encoder Card + 24 VDC

Operator Keypads

Standard operator keypad 6901-00-G

Features

- Local motor control: start, speed, direction, diagnostics
- Operator menus and parameter configuration
- Quick setup menu
- Password protection for parameter configuration

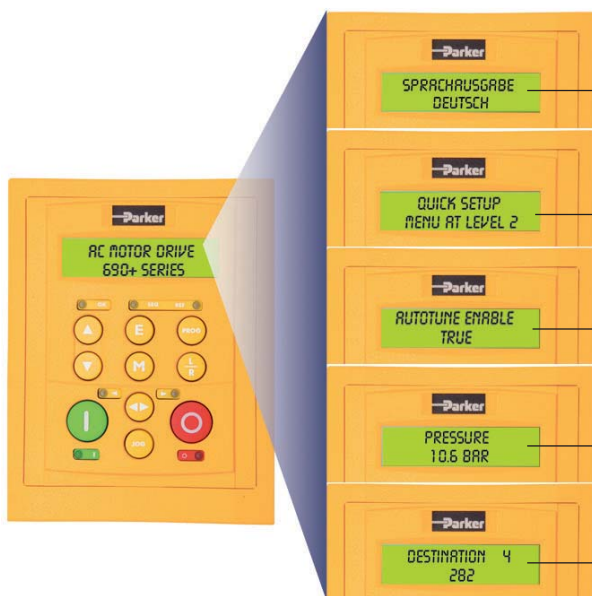

Multilingual

English · French · German · Italian
Portuguese · Swedish · Polish

Quick setup menu

Intuitive menus allowing easy and quick setup of the drive

Auto-tuning

Automatic tuning of motor parameters ensures maximum dynamic motor performance

Diagnostics messages

Display input and output parameters as well as drive operating units

Drive configuration

Drive System Explorer Lite (DSE Lite) Software

Description

DSE LITE software is an easy to use configuration, commissioning and monitoring tool with graphical interface for the Parker SSD Drives range of AC and DC drives. While the drive is in running mode the oscilloscope function allows "on-line" monitoring of selected parameters and the recording of trends.

DSE LITE, allows the user to create, parameterize and configure user defined applications thanks to function blocks dedicated to speed control, Winder, PID, Diameter calculator, Shaftless...

DSE LITE is downloadable from our website. www.parker.com

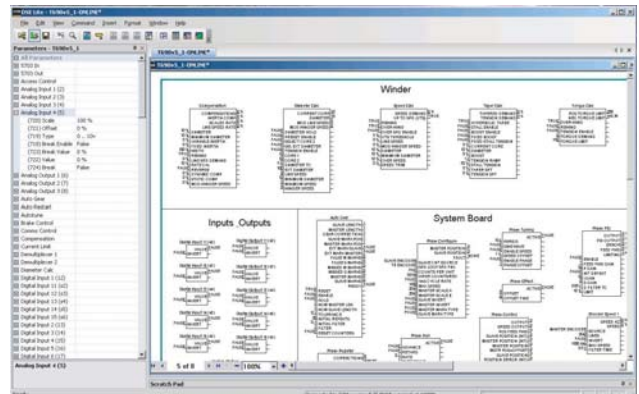
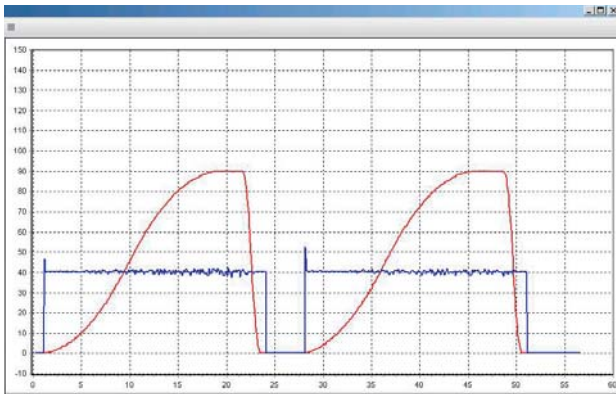

Order Codes

DC590+ Integrator Series, 110 V...500 V 3 phase

	1		2	3	4		5	6		7	8	9	10
Order example	590P	-	23	21501	0	-	P	00	-	U	0	A	0

1 Product Family

590P	DC590+ Series DC Digital Drive - 4 quadrant regenerative
591P	DC591+ Series DC Digital Drive - 2 quadrant non-regenerative

2 Supply Voltage

23	110...220 V 3 phase
53	220...500 V 3 phase

3 Current / Power Rating @110...220 VAC 3 ph

	Output current [A]	Frame
21501	15	1
23501	35	1
24002	40	2
27002	70	2
31102	110	2
31652	165	2
31803	180	3
32703	270	3
33804	380	4
35004	500	4
37254	725	4
38304	830	4
41585	1580	5

3 Current / Power Rating @220...500 VAC 3 ph

	Output current [A]	Frame
21501	15	1
23501	35	1
24002	40	2
27002	70	2
31102	110	2
31652	165	2
31803	180	3
32703	270	3
33804	380	4
35004	500	4
37254	725	4
38304	830	4
41585	1580	5
41256	1250	6
41606	1600	6
41956	1950	6
4120H	1200	H
4170H	1700	H
4220H	2200	H
4270H	2700	H

4 Auxiliary Supply

0	Universal 115 V...230 V 1 ph (Frames 1, 2, 6 & H)
1	115 V 1 ph (Frames 3,4,5)
2	230 V 1 ph (Frames 3,4,5)

5 Mounting

P	Panel mounting
A	Panel mounting + Airflow kit (option on Frames 4 & 5 only)

6 Special Options

00	None
	Documented special options (01...99) (refer to local sales office)

7 Languages

U	English (50/60 Hz)
D	German
E	Spansih
F	French
I	Italian

8 Keypad

0	None
4	6901 keypad fitted

9 Speed Feedback

A	Analogue tacho
V	Armature voltage
W	Wire-ended encoder

10 Communications

0	None
C	ControlNet
D	DeviceNet
E	EtherNet
M	ModBus +
N	CANopen
P	PROFIBUS
R	RS485/RS422

DC590+ Integrator Series 500 V...690 V 3 phase

	1		2	3	4		5	6		7	8	9	10
Order example	590P	-	63	33804	2	-	P	00	-	U	0	A	0

1 Product Family

590P	DC590+ Series DC Digital Drive - 4 quadrant regenerative
591P	DC591+ Series DC Digital Drive - 2 quadrant non-regenerative

2 Supply voltage

63	500...600 V 3 ph
73	500...690 V 3 ph

3 Current / Power Rating @500-600 V 3 ph

	Output current [A]	Frame
33804	380	4
35004	500	4
37254	725	4
38304	830	4
41585	1580	5

3 Current / Power Rating @500-690 V 3 ph

	Output current [A]	Frame
41256	1250	6
41606	1600	6
41956	1950	6
4120H	1200	H
4170H	1700	H
4220H	2200	H
4270H	2700	H

4 Auxiliary Supply

0	Universal 115 V...230 V 1ph (Frames 1, 2, 6 & H)
1	115 V 1 ph (Frames 3...5)
2	230 V 1 ph (Frames 3...5)

5 Mounting

P	Panel mounting
A	Panel mounting+ Airflow kit (option sur Frames 4 & 5 only)

6 Special Options

00	None
	Documented special options (01...99) (refer to local sales office)

7 Languages

U	English (50/60 Hz)
D	German
E	Spanish
F	French
I	Italian

8 Clavier

0	None
4	6901 keypad fitted

9 Retour vitesse

A	Analogue tacho
V	Armature voltage
W	Wire-ended encoder

10 Communications

0	None
C	ControlNet
D	DeviceNet
E	EtherNet
M	ModBus +
N	CANopen
P	PROFIBUS
R	RS485/RS422

DC590PX+ Integrator Series

	1		2	3	4		5	6		7	8	9	10
Order example	590PX	-	23	23501	0	-	P	00	-	U	0	A	0

1 Product family

590PX	DC590PX Series DC Digital Drive - regenerative
591PX	DC591PX Series DC Digital Drive - non-regenerative

2 Supply voltage

23	110...220 V 3 ph
53	220...500 V 3 ph

3 Current / Power Ratings @110...220 V 3 ph

	Output current [A]	Frame Size
23501	35	1
27001	70	1
31101	110	1
31501	150	1

3 Current / Power Ratings @220...500 V 3 ph

	Output current [A]	Frame Size
23501	35	1
27001	70	1
31101	110	1
31501	150	1

4 Auxiliary Supply

0	Universal 115 V...230 V 1 ph (35/70 Amp ratings only)
1	115 V 1 ph (110/150 Amp ratings only)
2	230 V 1 ph (10/150 Amp ratings only)

5 Mounting

P	Panel mounting
----------	----------------

6 Special Options

00	None
	Documented special options (01...99) (refer to local sales office)

7 Languages

U	English (50/60 Hz)
D	German
E	Spanish
F	French
I	Italian

8 Keypad

0	None
4	6901 keypad installed

9 Speed Feedback

A	Analogue tachometer
V	Armature voltage
W	Wire-ended encoder

10 Communications

0	None
C	ControlNet
D	DeviceNet
E	EtherNet
M	ModBus +
N	CANopen
P	PROFIBUS
R	RS485/RS422

DC590+ Series External Stack Controllers

	1		2	3	4		5	6	7		7	8	9	10
Order example	598P	-	23	26001	0	-	A	P	00	-	U	0	A	0

1 Product family

598P	DC598+ External Stack Controller - 2Q non-regenerative
599P	DC599+ External Stack Controller - 4Q Regenerative

2 Supply voltage

23	110...220 V 3 ph
53	220...500 V 3 ph
73	500...690 V 3 ph

3 Current / Power Ratings @110...220 V 3 ph

	Output current [A]	Frame Size
26001	60	1
31201	120	1

3 Current / Power Ratings @220...500 V 3 ph

	Output current [A]	Frame Size
26001	60	1
31201	120	1

3 Current / Power Ratings @500...690 V 3 ph

	Output current [A]	Frame Size
26001	60	1
31201	120	1

4 Auxiliary Supply

0	Universal 115 V...230 V 1 ph (60 Amp rating only)
1	115 V 1 ph (120 Amp rating only)
2	230 V 1 ph (120 Amp rating only)

5 Mounting

P	Panel mounting
----------	----------------

6 Special Options

00	None
	Documented special options (01...99) (refer to local sales office)

7 Languages

U	English (50/60 Hz)
D	German
E	Spanish
F	French
I	Italian

8 Keypad

0	None
4	6901 keypad installed

9 Speed Feedback

A	Analogue tachometer
V	Armature voltage
W	Wire-ended encoder

10 Communications

0	None
C	ControlNet
D	DeviceNet
E	EtherNet
M	ModBus +
N	CANopen
P	PROFIBUS
R	RS485/RS422

HMI Touchscreen - TS8000

Overview

Description

TS8000 is a high performance HMI touchscreen range with powerful features that would normally only be found in PC-based displays.

The TS8000 is able to communicate with many different pieces of hardware through its 10/100Base-T Ethernet port.

Furthermore a USB programming port allows programs to be downloaded, or access to trending and data logging, while data can be collected and stored on a standard CompactFlash card, freeing up internal memory.

Features

- Multi-lingual graphical interface
- Built-in symbol library of common objects
- Built-in web server
- CompactFlash support
- Integrated automatic multiple protocol conversion
- Free programming software
- Unicode support for multiple languages



Technical Characteristics - Overview

Power supply	24 VDC \pm 20 %
Operating Temperature	0...50 °C
Relative Humidity	80 % non-condensing
Altitude	2000 m
Enclosure	IP66 / Nema 4
Keypads	TS8003: 8 user assignable keys 5 navigation keys 12 numeric keys 7 dedicated keys TS8006: 5 keys for on screen menus TS8008: 7 keys for on screen menus TS8010: 8 keys for on screen menus TS8015: 9 keys for on screen menus
Memory	CompactFlash slot
Communications Ports	Programming: USB 1.1 - connector type B RS232 - via RJ12 Communication: RS232 - via RJ12 RS485 - via RJ45 Ethernet 10/100 Base T connector RJ45

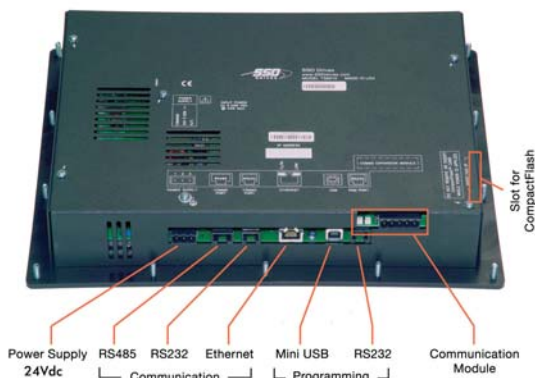

Application Example

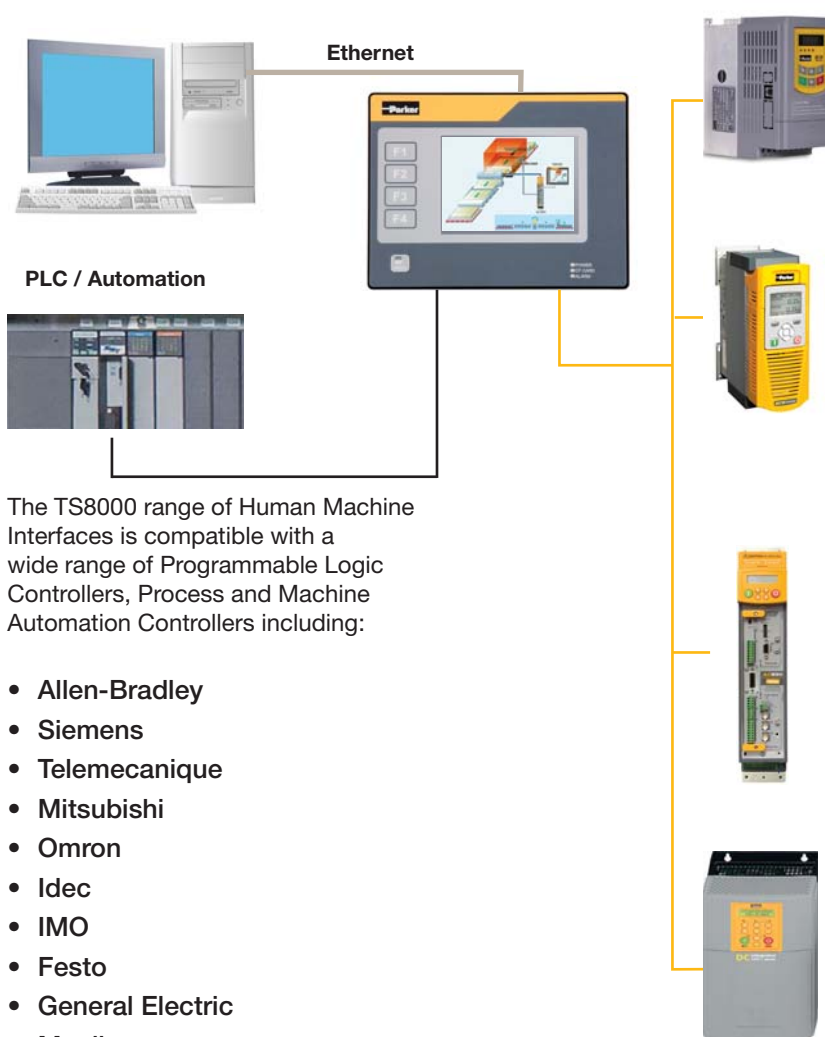

PLC / Automation

The TS8000 range of Human Machine Interfaces is compatible with a wide range of Programmable Logic Controllers, Process and Machine Automation Controllers including:

- Allen-Bradley
- Siemens
- Telemecanique
- Mitsubishi
- Omron
- Idec
- IMO
- Festo
- General Electric
- Moeller
- Matsushita
- Koyo

AC10 Series

- V/F Control
- Sensorless Vector Control

AC30 Series

- Sensorless Vector Control
- Closed-Loop Control

AC890 Series

- V/F Control
- Sensorless Vector Control
- Closed-Loop Vector Control
- AC Servo Control
- 4Q AFE Capability

DC590+ Series

- 2/4 Quadrant DC Drive

Pre-Engineered Projects

- Library with over 4000 symbols
- Support for BMP, JPG, WMF graphic files
- Database functionality
- Graphical Trend
- Alarm Logs
- Machine Drawings

Multilingual Interface

Programming and Display in:	
Italian	German
English	Spanish
French	Dutch

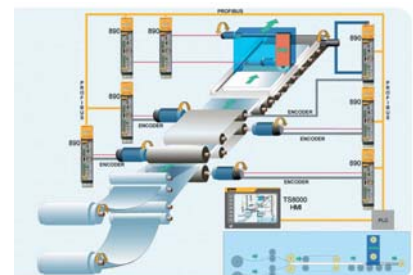
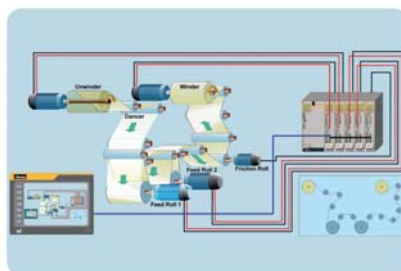
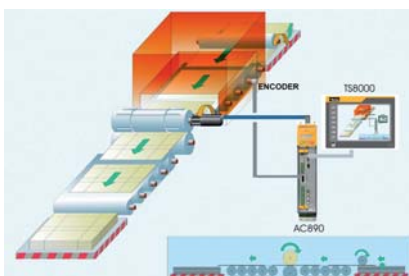

Technical Characteristics

Technical Data

Model	TS8003	TS8006	TS8008	TS8010	TS8015
Display size/type	3.2"/LCD	5.7"/STN	7.7"/DSTN	10.4"/TFT	15"/TFT
Pixel	128x64	320x240	640x480	640x480	1024x768
Colours	2 w. Backlight	256 QVGA	256 VGA	256 VGA	32 000 XGA
Brightness	-	165 cd/m ²	120 cd/m ²	350 cd/m ²	600 cd/m ²
Backlight ¹⁾	-	20 000 h typ.	40 000 h typ.	50 000 h typ.	50 000 h typ.
Keypad	8 user legendable keys, 5 navigation keys, 12 numeric keys, 4 dedicated keys, 3 soft keys	5 keys for on-screen menus	7 keys for on-screen menus	8 keys for on-screen menus	10 keys for on-screen menus
Touchscreen	Analog Resistive Type				
Memory					
Onboard memory:	4 Mb onboard nonvolatile flash memory		8 Mb onboard nonvolatile flash memory		32 Mb onboard nonvolatile flash memory
Memory card:	CompactFlash Type II slot for Type I and Type II CF cards				
Software	DSI8000 Software (included)				
Ports ²⁾					
USB	1x USB 1.1 - connector type B				
Serial:	2x RS232 - via RJ12 1x RS422/485 - via RJ45				
Ethernet:	Ethernet 10/100 Base T connector RJ45				
Power supply	24 VDC ±20 %				

¹⁾ Lifetime at 20 °C.

²⁾ Serial Ports: Format and baud rates are individually programmable up to 115.2 kb.

Construction

Housing

Steel rear metal enclosure with NEMA 4X/IP66 aluminum front plate when correctly fitted with the provided gasket. Installation Category II, Pollution Degree 2

Environmental Conditions

Temperature range

- Operating temperature: 0...50 °C
- Storage temperature: -20...70 °C (TS8003, TS8006, TS8015) or 80 °C (TS8008, TS8010)

Humidity

- Operating and Storage: 80 % maximum relative humidity (non-condensing) from 0...50 °C

Altitude

- Up to 2000 m

Certifications and Compliances

International Standards

- IEC 1010-1, EN 61010-1: Safety requirements for electrical equipment for measurement, control, and laboratory use, Part 1
- EN 61326
- EN 55011 Class A
- IP66 enclosure rating (face only), IEC 529
- Type 4X enclosure rating (face only), UL50
- CE compliance

Electromagnetic Compatibility

- Emissions and immunity to EN 61326: Electrical equipment for measurement, control, and laboratory use, Part 1.
- Electrostatic discharge: EN 61000-4-2 Criterion A
4 kV contact xchrg, 8 kV air xchrg
 - Electromagnetic RF fields: EN 61000-4-3 Criterion B
10 V/m
 - Fast transients (burst): EN 61000-4-4 Criterion B
2 kV power, 2 kV signal
 - Surge: EN 61000-4-5 Criterion A
1 kV L-L, 2 kV L&N-E power
 - RF conducted interference: EN 61000-4-6 Criterion B
3 Veff
 - Emissions: EN 55011 Class A

Notes: Criterion A (normal operation within specified limits), Criterion B (temporary loss of performance from which the unit self recovers).

Dimensions



Model	a [mm]	b [mm]	c [mm]	d [mm]	e [mm]	Weight [kg]
TS8003	189.2	148.6	52	153.4	112.8	0.89
TS8006	224.3	179.8	58.4	188.5	144	1.36
TS8008	262	207.8	56	226.3	172	1.74
TS8010	325.8	241.3	55	293.3	210.1	2.51
TS8015	406.4	330.2	71.5	370.6	294.4	5.17

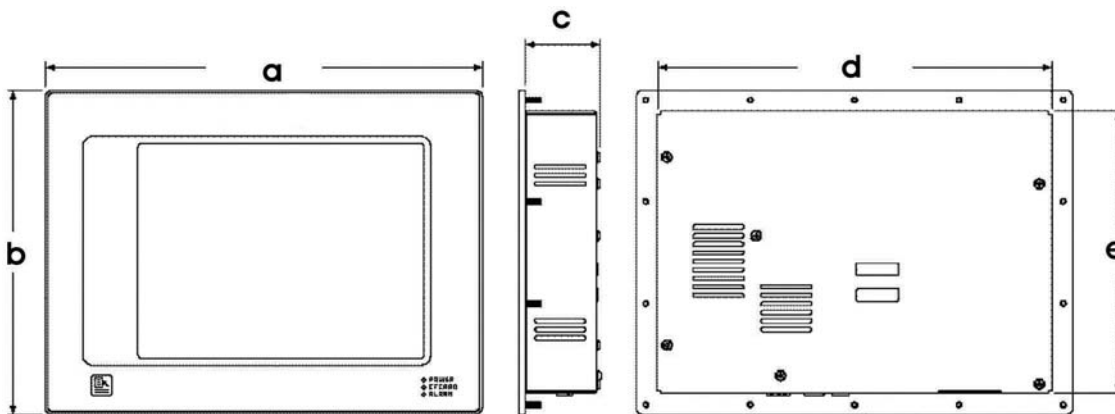

Options

Fieldbus

Description

The TS8000 communication cards allow connection and integration of the TS8000 into many popular fieldbus communication networks.

CANopen Communications Interface

Order Code: 8000-CB-00

Supported Protocols	CANopen SDO Master
Communication Speed	Selectable by software up to 1 Mbits/s
Communication	With Drive System Explorer software using RTNX protocol
Suitable for drives	AC890 version 3.2+

DeviceNet Communications Interface

Order Code: 8000-DN-00

Supported Protocols	DeviceNet – Slave Group 2 only
Communication Speed	Selectable by software up to 500 kbits/s

Firewire Communications Interface

Order Code: 8000-FA-00

This card allows data exchange between the TS8000 and an AC890 fitted with an 8903-FA-00 Interface

Communication Ports	Port A: IEEE 1394A Port B: IEEE 1394B
----------------------------	--

Note: The TS8000 must use a Class 2 or SELV rated power supply.

PROFIBUS-DP Communications Interface

Order Code: 8000-PB-00

Supported Protocols	EN50 170, 1
Communication Speed	Up to 12 Mbits/s

Software

DSI3 Programming Software

TS8006 - TS8015

This latest version of Parker's programming software for the TS8000 range features a number of new drivers enabling users to have access to one of the widest range of protocols on the market; in the order of 250.

The multiple protocol support of the TS8000 series means a second protocol can be used to acquire data from the original driver. Once collected, the TS8000 series can convert the data to a different protocol so that it can be integrated with virtually any PLC, PC or SCADA system. The data may also be recorded in IT-friendly CSV file format for later review, using the built-in data logging facilities.

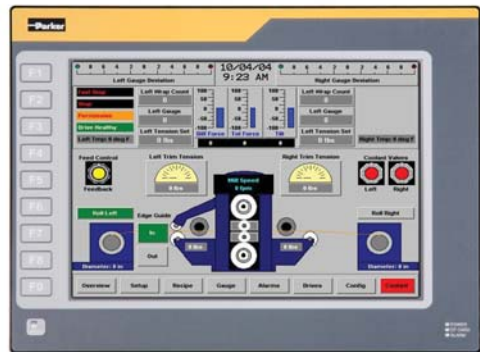
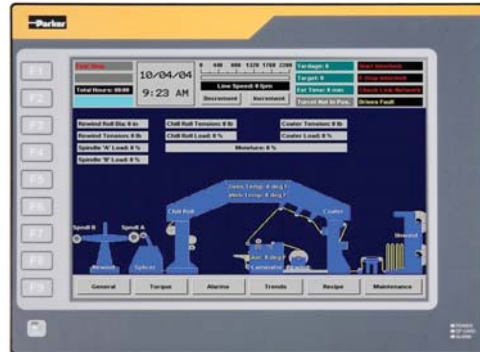

DSI8000 Programming Software

This previous version of programming software can be used for the whole range of TS8000 displays, and must be used for the TS8003 display.

While the functionality is essentially the same between the DSI8000 and DSI3 software, the DSI3 includes enhanced graphics and images, drag and drop tags for fast parameter allocation and simplifies programming version 2 hardware that is used on the TS8008 and TS8010.

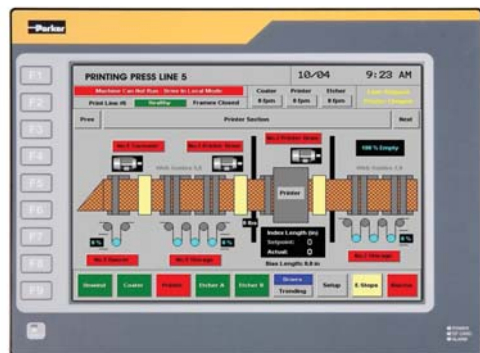

Order Code

TS8000

	1
Order example	TS8003/00/00

1	HMI Touchscreen
TS8003/00/00	3.2" FSTN Display
TS8006/00/00	5.7" TFT Display
TS8008/00/02	7.7" TFT Display
TS8010/00/02	10.4" TFT Display
TS8015/00/00	15" TFT Display

Accessories & Options

Fieldbus

	1
Order example	8000/CB/00

1	Fieldbus
8000/CB/00	CANopen fieldbus option card (master)
8000/DN/00	DeviceNet option card
8000/PB/00	PROFIBUS option card
8000/FA/00	FireWire fieldbus option card

Square Frame Three-Phase Induction Motors - MS Series Motor 0.75 kW - 524 kW

Overview

Description

The MS series of AC induction motors has been specially engineered to be suitable for high dynamic performance when used with a flux vector type controller - AC890 and AC690+. They permit operation in constant power at maximum speed up to 8000 min⁻¹

- Compact square frame format
- Same frame dimensions as DC motors of similar power rating
- IP23 or IP54 protection
- Auxiliary cooling fan allows low-speed, high-torque operation
- High overload capability
- Higher operating speeds
- 360 V (Contact your local sales office for details)
- PTC thermister (option)
- IP55 protection (option)
- Insulated bearings (option)
- Encoder or resolver feedback (option)



Technical Characteristics - Overview

Motor type	Square Frame Three-Phase Induction Motor
Power range	0.75 kW ... 524 kW
Speed range	0 ... 8000 min ⁻¹
Protection level	IP23 or IP54
Feedback	Encoder or resolver (optional)
Suitable for drives	AC30V, AC690+, AC890, AC890PX-M



Technical Features

MS133 Series: 13 kW - 60 kW, 3 x 400 VAC (IP23)

Order Code	Motor	Code	Nominal speed nn [min ⁻¹]	Nominal power Pn [KW]	Nominal torque Tn [Nm]	Inertia J [kgcm ²]	Nominal voltage Vn [VRMS]	Nominal current In [ARMS]	Magnetising current Iμ [ARMS]	Nominal frequency Fn [Hz]	Max. speed at Pn Nmax1 [min ⁻¹]	Max. speed Nmax2 [min ⁻¹]	Weight W [kg]
MS24133KEC...	MS133	K EC	800	13	155	670	395	28	9	28.9	1000	7 000	132
MS24133KEB...		K EB	1000	16	153	670	395	33	10	35.7	1200	7 000	132
MS24133KE3...		K E3	1350	21	149	670	400	42	14	47.2	1500	7 000	132
MS24133KFA...		K FA	1500	23	146	670	395	45	14	52.2	1900	7 000	132
MS24133KF2...		K F2	1800	27	143	670	400	52	17	62.1	2100	7 000	132
MS24133KF3...		K F3	2000	30	142	670	400	57	19	68.7	2300	7 000	132
MS24133KG1...		K G1	2500	36	138	670	395	70	26	85.3	3700	7 000	132
MS24133KGB...		K GB	3000	42	134	670	400	79	28	101.9	3600	7 000	132
MS24133SE2...		S E2	850	19	213	860	385	40	13	30.3	1400	7 000	157
MS24133SEC...		S EC	1000	22	210	860	385	45	15	35.3	1700	7 000	157
MS24133SE3...		S E3	1250	27	206	860	400	52	18	43.5	1500	7 000	157
MS24133SFB...		S FB	1500	31	197	860	400	59	20	51.9	1700	7 000	157
MS24133SF2...		S F2	1800	35	186	860	400	67	24	61.8	2200	7 000	157
MS24133SF4...		S F4	2050	39	182	860	400	75	28	70.0	2600	7 000	157
MS24133SG1...		S G1	2450	43	168	860	400	83	31	83.3	3100	7 000	157
MS24133SGB...		S GB	3000	49	156	860	400	93	37	101.5	3900	7 000	157
MS24133ME4...		M E4	850	21	236	980	395	43	14	30.3	1100	7 000	175
MS24133ME3...		M E3	1000	24	229	980	390	49	17	35.2	1600	7 000	175
MS24133MEB...		M EB	1250	29	222	980	395	58	20	43.5	1800	7 000	175
MS24133MFB...		M FB	1500	34	216	980	395	67	24	51.8	2200	7 000	175
MS24133MF2...	M F2	1800	39	207	980	400	74	26	61.8	2100	7 000	175	
MS24133MF3...	M F3	2100	42	191	980	400	81	32	71.6	2700	7 000	175	
MS24133MG1...	M G1	2500	47	180	980	395	92	39	84.8	4100	7 000	175	
MS24133MG2...	M G2	2850	50	168	980	400	97	42	96.4	4000	7 000	175	
MS24133PE7...	P E7	800	23	275	1200	385	48	16	28.4	1400	7000	200	
MS24133PED...	P ED	1000	28	267	1200	390	56	20	35.0	1600	7000	200	
MS24133PFC...	P FC	1350	36	255	1200	400	69	25	46.6	1600	7000	200	
MS24133PFB...	P FB	1500	39	248	1200	390	77	31	51.5	2700	7000	200	
MS24133PF2...	P F2	1850	45	232	1200	400	86	36	63.1	2500	7000	200	
MS24133PF3...	P F3	2100	48	218	1200	400	92	37	71.4	2600	7000	200	
MS24133PG1...	P G1	2600	54	198	1200	395	105	47	87.9	4400	7000	200	
MS24133PG2...	P G2	3000	57	181	1200	400	112	56	101.1	4500	7000	200	
MS24133XE3...	X E3	850	25	281	1260	395	51	19	29.9	1200	7000	220	
MS24133XEB...	X EB	1000	29	277	1260	390	59	23	34.8	1700	7000	220	
MS24133XF3...	X F3	1250	36	275	1260	395	71	28	43.2	1900	7000	220	
MS24133XFA...	X FA	1500	42	267	1260	400	81	32	51.5	1900	7000	220	
MS24133XF1...	X F1	1800	47	249	1260	395	92	39	61.4	2900	7000	220	
MS24133XF2...	X F2	2000	50	239	1260	390	98	42	68.0	3800	7000	220	
MS24133XG1...	X G1	2600	57	209	1260	390	114	55	87.8	5600	7000	220	
MS24133XG2...	X G2	3000	60	191	1260	380	125	63	101.1	7000	7000	220	

MS160 Series: 30 kW - 114 kW, 3 x 400 VAC (IP23)

Order Code	Motor	Code	Nominal speed nn [min ⁻¹]	Nominal power Pn [KW]	Nominal torque Tn [Nm]	Inertia J [kgcm ²]	Nominal voltage Vn [VRMS]	Nominal current In [ARMS]	Magnetising current Iμ [ARMS]	Nominal frequency Fn [Hz]	Max. speed at Pn Nmax1 [min ⁻¹]	Max. speed Nmax2 [min ⁻¹]	Weight W [kg]
MS24160ME3...	MS160	M E3	650	30	441	2400	395	62	17	23.7	800	6 000	270
MS24160MEA...		M EA	900	40	424	2400	400	79	23	31.9	1000	6 000	270
MS24160ME8...		M E8	1000	44	420	2400	385	89	27	35.2	1700	6 000	270
MS24160MF4...		M F4	1300	56	411	2400	400	106	33	45.2	1600	6 000	270
MS24160MFA...		M FA	1500	63	401	2400	400	120	39	51.8	1900	6 000	270
MS24160MFE...		M FE	1800	73	387	2400	400	138	45	61.8	2300	6 000	270
MS24160MF5...		M F5	2000	80	382	2400	390	153	51	68.4	3300	6 000	270
MS24160MG2...		M G2	2600	96	353	2400	400	180	64	88.3	3600	6 000	270
MS24160LED...		L ED	650	34	500	3020	400	68	22	23.3	800	6 000	325
MS24160LEA...		L EA	850	44	494	3020	390	87	29	29.9	1400	6 000	325
MS24160LE5...		L E5	1000	51	487	3020	400	98	33	34.9	1300	6 000	325
MS24160LFB...		L FB	1300	64	470	3020	400	121	43	44.8	1800	6 000	325
MS24160LF4...		L F4	1500	71	452	3020	400	132	47	51.4	2000	6 000	325
MS24160LF3...		L F3	1850	84	434	3020	400	156	59	63.0	2700	6 000	325
MS24160LFA...		L FA	2000	88	420	3020	400	165	65	68.0	3000	6 000	325
MS24160LG1...		L G1	2450	99	386	3020	400	186	77	82.9	3800	6 000	325
MS24160PEC...		P EC	700	42	573	3600	390	85	29	24.8	1300	5 000	365
MS24160PEB...		P EB	850	50	562	3600	395	99	35	29.7	1400	5 000	365
MS24160PE4...		P E4	1000	58	554	3600	395	111	41	34.7	1700	5 000	365
MS24160PFA...		P FA	1300	73	536	3600	395	138	51	44.6	2200	5 000	365
MS24160PF1...		P F1	1500	82	522	3600	395	156	60	51.3	2700	5 000	365
MS24160PFB...		P FB	1800	94	499	3600	395	177	70	61.2	3300	5 000	365
MS24160PFC...		P FC	2000	100	477	3600	395	189	76	67.8	3800	5 000	365
MS24160PG2...		P G2	2500	110	420	3600	395	213	97	84.4	5000	5 000	365
MS24160XE3...		X E3	650	44	639	3900	385	90	30	23.1	1200	4500	395
MS24160XEB...		X EB	850	56	629	3900	390	110	28	29.7	1400	4500	395
MS24160XE1...		X E1	1000	65	621	3900	385	128	45	34.7	1900	4500	395
MS24160XF5...		X F5	1300	81	595	3900	400	151	53	44.7	1500	4500	395
MS24160XF3...		X F3	1500	91	579	3900	395	171	63	51.3	2300	4500	395
MS24160XF2...		X F2	1800	102	541	3900	390	193	75	61.2	3300	4500	395
MS24160XFC...	X FC	2000	108	516	3900	390	206	85	67.8	3900	4500	395	
MS24160XG1...	X G1	2500	114	435	3900	400	208	82	84.4	3000	4500	395	

Square Frame Asynchronous Motors
 MS180 Series: 47 kW - 162 kW, 3 x 400VAC (IP23)

MS180 Series: 47 kW - 162 kW, 3 x 400 VAC (IP23)

Order Code	Motor	Code	Nominal speed nn [min ⁻¹]	Nominal power Pn [KW]	Nominal torque Tn [Nm]	Inertia J [kgcm ²]	Nominal voltage Vn [VRMS]	Nominal current In [ARMS]	Magnetising current Iμ [ARMS]	Nominal frequency Fn [Hz]	Max. speed at Pn Nmax1 [min ⁻¹]	Max. speed Nmax2 [min ⁻¹]	Weight W [kg]
MS24180ME5...	MS180	M E5	650	47	690	5050	390	92	26	22.8	900	4 500	480
MS24180MEC...		M EC	850	61	685	5050	395	115	34	29.5	1100	4 500	480
MS24180MED...		M ED	1000	71	678	5050	395	129	39	34.4	1300	4 500	480
MS24180MEB...		M EB	1300	89	654	5050	395	158	49	44.4	1800	4 500	480
MS24180MFB...		M FB	1500	100	637	5050	395	178	58	51.0	2100	4 500	480
MS24180MF1...		M F1	1800	112	594	5050	400	198	69	60.9	2100	4 500	480
MS24180MF2...		M F2	2050	118	550	5050	385	215	67	69.3	3700	4 500	480
MS24180MG1...		M G1	2500	122	466	5050	380	225	63	84.4	4500	4 500	480
MS24180PED...		P ED	650	60	881	6300	395	117	35	23.0	800	4 500	550
MS24180PE7...		P E7	850	78	876	6300	390	147	46	29.7	1300	4 500	550
MS24180PE4...		P E4	1000	90	859	6300	390	164	49	34.7	1500	4 500	550
MS24180PE6...		P E6	1250	109	833	6300	390	200	64	42.9	2000	4 500	550
MS24180PFB...		P FB	1500	124	789	6300	385	232	77	51.2	2800	4 500	550
MS24180PFA...		P FA	1750	135	737	6300	395	242	83	59.5	2600	4 500	550
MS24180PF1...		P F1	2050	146	680	6300	390	262	85	69.5	3400	4 500	550
MS24180PG1...		P G1	2500	155	592	6300	385	285	86	84.6	4500	4 500	550
MS24180XE5...		X E5	650	65	955	7300	390	125	38	23.1	1000	4000	590
MS24180XE6...		X E6	850	84	94	7300	395	156	46	29.8	1100	4000	590
MS24180XE3...		X E3	1000	97	926	7300	395	178	51	34.8	1300	4000	590
MS24180XEA...		X EA	1300	119	874	7300	395	216	65	44.7	1700	4000	590
MS24180XF2...	X F2	1600	138	824	7300	395	248	81	54.6	2200	4000	590	
MS24180XF1...	X F1	1800	148	785	7300	395	265	93	61.2	2700	4000	590	
MS24180XG1...	X G1	2300	162	673	7300	395	285	88	78.0	3100	4000	590	

MS225 - MS280 Series: 71 kW - 524 kW, 3 x 400 VAC (IP23)

Order Code	Motor	Code	Nominal speed nn [min ⁻¹]	Nominal power Pn [KW]	Nominal torque Tn [Nm]	Inertia J [kgcm ²]	Nominal voltage Vn [VRMS]	Nominal current In [ARMS]	Magnetising current Iμ [ARMS]	Nominal frequency Fn [Hz]	Max. speed at Pn Nmax1 [min ⁻¹]	Max. speed Nmax2 [min ⁻¹]	Weight W [kg]
MS24225SE4...	MS225	S E4	650	71	1043	10500	395	135	34	22.7	800	3 500	640
MS24225SEC...		S EC	800	86	1027	10500	395	161	42	27.6	1000	3 500	640
MS24225SE5...		S E5	1000	104	993	10500	385	200	58	34.3	1600	3 500	640
MS24225SFB...		S FB	1250	124	947	10500	390	233	65	42.6	1800	3 500	640
MS24225SFA...		S FA	1500	144	917	10500	400	260	74	50.9	1700	3 500	640
MS24225SF1...		S F1	1800	161	854	10500	390	295	80	60.9	2700	3 500	640
MS24225SF2...		S F2	2000	176	840	10500	390	320	86	67.5	2900	3 500	640
MS24225LE3...		L E3	650	95	1396	15000	395	178	46	22.7	800	3 500	860
MS24225LEA...		L EA	850	122	1370	15000	390	230	62	29.3	1300	3 500	860
MS24225LEC...		L EC	1000	141	1346	15000	395	255	70	34.3	1300	3 500	860
MS24225LE2...		L E2	1300	174	1278	15000	400	310	91	44.2	1500	3 500	860
MS24225LFA...		L FA	1450	190	1251	15000	400	336	98	49.2	1700	3 500	860
MS24225LF1...		L F1	1800	216	1146	15000	390	391	115	60.8	2800	3 500	860
MS24225XE3...		X E3	650	139	2042	21300	395	254	65	22.7	800	3500	1080
MS24225XE4...		X E4	800	169	2017	21300	385	313	82	27.7	1400	3500	1080
MS24225XEB...		X EB	1000	208	1986	21300	395	370	98	34.4	1300	3500	1080
MS24225XE1...		X E1	1250	250	1910	21300	390	447	123	42.7	2000	3500	1080
MS24225XFA...		X FA	1450	280	1844	21300	395	493	143	49.3	2100	3500	1080
MS24225XF1...		X F1	1700	305	1713	21300	390	540	163	57.6	3000	3500	1080
MS24280MEA...	MS280	M EA	690	210	2906	39330	395	370	78	23.7	900	3000	1290
MS24280ME1...		M E1	840	252	2865	39330	395	439	93	28.7	1100	3000	1290
MS24280ME2...		M E2	1060	311	2802	39330	395	536	117	36.0	1400	3000	1290
MS24280MF1...		M F1	1450	407	2680	39330	400	686	155	49.0	1500	3000	1290
MS24280LEA...		L EA	560	206	3512	47250	395	366	79	19.4	700	3000	1520
MS24280LE1...		L E1	680	247	3468	47250	395	434	95	23.3	900	3000	1520
MS24280LE2...		L E2	870	309	3391	47250	395	535	115	29.7	1100	3000	1520
MS24280LF1...		L F1	1170	401	3273	47250	395	688	156	39.7	1600	3000	1520
MS24280XEA...		X EA	470	189	3840	56820	395	347	86	16.4	600	2800	1890
MS24280XE1...		X E1	520	226	3786	56820	395	410	105	19.7	700	2800	1890
MS24280XE2...		X E2	720	281	3727	56820	395	503	132	24.7	900	2800	1890
MS24280XF1...		X F1	980	371	3615	56820	395	656	173	33.3	1300	2800	1890
MS24280XF2...		X F2	1510	524	3314	56820	400	907	262	50.9	1600	2800	1890

MS100 Series: 2.5 kW - 17 kW, 3 x 400 VAC (IP54)

Order Code	Motor	Code	Nominal speed nn [min ⁻¹]	Nominal power Pn [KW]	Nominal torque Tn [Nm]	Inertia J [kgcm ²]	Nominal voltage Vn [VRMS]	Nominal current In [ARMS]	Magnetising current Iμ [ARMS]	Nominal frequency Fn [Hz]	Max. speed at Pn Nmax1 [min ⁻¹]	Max. speed Nmax2 [min ⁻¹]	Weight W [kg]
MS54100SE2...	MS100	S E2	1000	2.5	23.9	190	395	5.9	2.5	35.8	1200	8000	50
MS54100SE1...		S E1	1200	3.0	23.8	190	395	6.9	3.1	42.4	1500	8000	50
MS54100SFA...		S FA	1500	3.7	23.6	190	380	9.0	4.2	52.3	2600	8000	50
MS54100SF1...		S F1	1750	4.3	23.5	190	395	10.0	4.7	60.7	2400	8000	50
MS54100SF2...		S F2	2000	4.9	23.4	190	380	11.8	5.5	69.0	3400	8000	50
MS54100SF3...		S F3	2400	5.7	22.7	190	395	13.3	6.5	82.2	3400	8000	50
MS54100SG2...		S G2	3000	6.8	21.6	190	390	16.3	8.3	102.2	4700	8000	50
MS54100MEA...		M EA	1000	4.1	39.2	250	395	9.4	3.9	35.6	1200	8000	65
MS54100ME2...		M E2	1200	4.9	38.8	250	400	11.0	5.1	42.1	1300	8000	65
MS54100MFB...		M FB	1500	6.0	38.2	250	385	13.7	6.1	52.1	2400	8000	65
MS54100MF1...		M F1	1750	6.9	37.7	250	400	15.2	6.8	60.5	1900	8000	65
MS54100MF3...		M F3	2100	8.1	36.8	250	400	17.8	8.4	72.0	2500	8000	65
MS54100MG1...		M G1	2700	10.0	35.4	250	400	21.9	10.6	92.0	3400	8000	65
MS54100MG2...		M G2	3000	11.0	35.0	250	400	24.2	11.2	102.1	3600	8000	65
MS54100LE2...		L E2	1000	5.7	54.4	310	400	13.0	5.8	35.4	1200	8000	80
MS54100LE1...		L E1	1250	7.0	53.5	310	400	15.7	7.1	43.7	1500	8000	80
MS54100LFC...		L FC	1500	8.2	52.2	310	390	18.4	8.3	52.0	2300	8000	80
MS54100LF1...		L F1	1800	9.6	50.9	310	400	21.0	9.6	62.0	2200	8000	80
MS54100LF2...		L F2	1900	10.0	50.3	310	395	23.5	10.8	65.4	2700	8000	80
MS54100LGA...		L GA	2400	12.2	48.5	310	400	27.0	12.8	82.0	2900	8000	80
MS54100LG1...	L G1	2700	13.3	47.0	310	395	28.8	13.8	91.9	3900	8000	80	
MS54100LG2...	L G2	3000	14.5	46.2	310	390	32.0	15.6	101.9	5000	8000	80	
MS54100PEB...	P EB	1000	6.9	66.2	370	395	15.1	6.6	35.3	1300	8000	90	
MS54100PE2...	P E2	1300	8.8	64.8	370	400	19.3	9.1	45.2	1500	8000	90	
MS54100PFB...	P FB	1500	10.0	63.7	370	380	23.0	11.5	51.8	3100	8000	90	
MS54100PF1...	P F1	1750	11.4	62.2	370	395	25.0	12.2	60.1	2600	8000	90	
MS54100PF2...	P F2	2000	12.8	61.0	370	400	28.3	13.0	68.6	2200	8000	90	
MS54100PGA...	P GA	2500	15.1	57.8	370	390	33.0	16.8	85.0	4400	8000	90	
MS54100PG2...	P G2	3000	17.0	54.1	370	400	36.8	19.1	101.6	3900	8000	90	

MS133 Series: 9.5 kW - 47 kW, 3 x 400 VAC (IP54)

Order Code	Motor	Code	Nominal speed nn [min ⁻¹]	Nominal power Pn [KW]	Nominal torque Tn [Nm]	Inertia J [kgcm ²]	Nominal voltage Vn [VRMS]	Nominal current In [ARMS]	Magnetising current Iμ [ARMS]	Nominal frequency Fn [Hz]	Max. speed at Pn Nmax1 [min ⁻¹]	Max. speed Nmax2 [min ⁻¹]	Weight W [kg]
MS54133KEC...	MS133	K EC	850	9.5	107	670	395	21	9	29.9	1400	7 000	132
MS54133KEB...		K EB	1000	11	105	670	385	24	11	34.9	2200	7 000	132
MS54133KE5...		K E5	1200	13	103	670	400	29	14	41.5	1900	7 000	132
MS54133KFA...		K FA	1500	16	102	670	390	34	15	51.6	2800	7 000	132
MS54133KF2...		K F2	1800	19	101	670	395	40	18	61.5	3100	7 000	132
MS54133KF3...		K F3	2000	21	100	670	395	43	20	68.1	3600	7 000	132
MS54133KGA...		K GA	2500	25	95	670	400	51	22	84.8	3400	7 000	132
MS54133KGB...		K GB	3000	29	92	670	395	60	29	101.4	5500	7 000	132
MS54133SE4...		S E4	850	13	146	860	390	28	12	29.8	1600	7 000	157
MS54133SEB...		S EB	1000	15	143	860	395	31	14	34.7	1700	7 000	157
MS54133SED...		S ED	1250	18	138	860	400	37	17	43.0	1700	7 000	157
MS54133SFA...		S FA	1500	21	134	860	400	42	18	51.4	1900	7 000	157
MS54133SF2...		S F2	1800	24	127	860	395	50	25	61.2	3400	7 000	157
MS54133SF4...		S F4	2100	27	123	860	390	55	26	71.2	4500	7 000	157
MS54133SG1...		S G1	2600	31	114	860	400	62	29	87.9	3700	7 000	157
MS54133SGB...		S GB	3000	34	108	860	395	71	37	101.0	6100	7 000	157
MS54133ME4...		M E4	850	15	169	980	385	33	14	29.8	1800	7 000	175
MS54133ME2...		M E2	1000	17	162	980	400	35	14	34.8	1200	7 000	175
MS54133MEB...		M EB	1300	21	156	980	400	44	21	44.6	1900	7 000	175
MS54133MFA...		M FA	1500	24	153	980	395	48	21	51.3	2500	7 000	175
MS54133MF2...		M F2	1800	27	143	980	395	56	27	61.2	3400	7 000	175
MS54133MF3...		M F3	2100	30	136	980	390	63	31	71.2	4600	7 000	175
MS54133MG1...		M G1	2600	34	125	980	395	71	37	87.8	5200	7 000	175
MS54133MG2...		M G2	3000	37	118	980	400	75	39	101.0	4700	7 000	175
MS54133PE7...		P E7	850	18	202	1200	395	39	16	29.7	1300	7 000	200
MS54133PE3...		P E3	1000	21	201	1200	400	44	19	34.7	1300	7 000	200
MS54133PF4...		P F4	1300	27	198	1200	400	52	23	44.6	1700	7 000	200
MS54133PFA...		P FA	1500	30	191	1200	400	58	26	51.2	2000	7 000	200
MS54133PF1...		P F1	1800	33	175	1200	400	65	29	61.2	2400	7 000	200
MS54133PF3...		P F3	2100	36	164	1200	390	73	36	71.1	4600	7 000	200
MS54133PG1...		P G1	2600	40	147	1200	385	85	46	87.6	7000	7 000	200
MS54133PG2...		P G2	3000	43	137	1200	390	93	53	100.9	7000	7 000	200
MS54133XE3...	X E3	850	20	225	1260	385	42	19	29.6	1900	7000	220	
MS54133XE2...	X E2	1000	23	220	1260	400	46	21	34.5	1300	7000	220	
MS54133XF3...	X F3	1300	29	213	1260	400	58	27	44.5	1800	7000	220	
MS54133XFA...	X FA	1500	33	210	1260	390	67	31	51.2	3100	7000	220	
MS54133XF1...	X F1	1800	37	196	1260	390	76	39	61.1	4100	7000	220	
MS54133XF2...	X F2	2100	40	182	1260	400	80	41	71.0	3200	7000	220	
MS54133XG1...	X G1	2600	45	165	1260	385	96	54	87.6	7000	7000	220	
MS54133XG2...	X G2	3000	47	150	1260	380	106	64	100.8	7000	7000	220	

Square Frame Asynchronous Motors
MS160 Series: 19 kW - 67 kW, 3 x 400VAC (IP54)

MS160 Series: 19 kW - 67 kW, 3 x 400 VAC (IP54)

Order Code	Motor	Code	Nominal speed nn [min ⁻¹]	Nominal power Pn [KW]	Nominal torque Tn [Nm]	Inertia J [kgcm ²]	Nominal voltage Vn [Vrms]	Nominal current In [Arms]	Magnetising current Iμ [Arms]	Nominal frequency Fn [Hz]	Max. speed at Pn Nmax1 [min ⁻¹]	Max. speed Nmax2 [min ⁻¹]	Weight W [kg]
MS54160MEB...	MS160	M EB	650	19	279	2400	395	35	13	23.0	1000	6 000	255
MS54160MEC...		M EC	850	24	270	2400	400	43	17	29.6	1100	6 000	255
MS54160MEA...		M EA	1000	28	267	2400	390	51	20	34.6	1900	6 000	255
MS54160ME1...		M E1	1300	35	257	2400	400	61	24	44.6	1700	6 000	255
MS54160MFC...		M FC	1500	40	255	2400	390	72	28	51.2	2900	6 000	255
MS54160MF1...		M F1	1800	45	239	2400	400	79	33	61.2	2600	6 000	255
MS54160MFE...		M FE	2000	48	229	2400	395	86	37	67.8	3600	6 000	255
MS54160MF5...		M F5	2250	51	216	2400	390	93	42	76.1	5000	6 000	255
MS54160MGB...		M GB	2500	53	202	2400	400	93	44	84.3	4100	6 000	255
MS54160LE6...		L E6	650	22	323	3020	395	43	16	22.9	1000	6000	310
MS54160LE4...		L E4	850	28	315	3020	390	56	22	29.5	1700	6000	310
MS54160LEA...		L EA	1000	33	315	3020	400	62	23	34.5	1200	6000	310
MS54160LE3...		L E3	1300	40	294	3020	395	77	31	44.4	2300	6000	310
MS54160LFB...		L FB	1500	45	287	3020	400	84	33	51.1	2000	6000	310
MS54160LF1...		L F1	1750	50	273	3020	395	96	42	59.3	3300	6000	310
MS54160LF2...		L F2	1950	53	260	3020	400	100	42	66.0	2800	6000	310
MS54160LFA...		L FA	2250	57	242	3020	400	110	52	75.9	3700	6000	310
MS54160LG2...		L G2	2500	59	225	3020	400	114	55	84.2	4100	6000	310
MS54160PE5...		P E5	650	23	338	3600	395	47	19	22.7	1200	5 000	350
MS54160PEC...		P EC	850	30	337	3600	400	58	22	29.4	1100	5 000	350
MS54160PEA...	P EA	1000	35	334	3600	390	69	30	34.3	2300	5 000	350	
MS54160PE2...	P E2	1300	44	323	3600	400	83	36	44.3	2100	5 000	350	
MS54160PFA...	P FA	1500	49	312	3600	400	93	40	50.9	2400	5 000	350	
MS54160PF1...	P F1	1750	55	300	3600	400	104	46	59.2	2800	5 000	350	
MS54160PFB...	P FB	2000	60	286	3600	390	119	56	67.5	5000	5 000	350	
MS54160PG1...	P G1	2400	64	255	3600	385	133	70	80.7	5000	5 000	350	
MS54160XE4.	X E4	650	28	411	3900	395	56	22	22.8	1000	4500	395	
MS54160XEC..	X EC	850	36	404	3900	395	69	27	29.4	1300	4500	395	
MS54160XEA..	X EA	1000	41	392	3900	395	81	33	34.4	2300	4500	395	
MS54160XED..	X ED	1250	49	374	3900	395	94	39	42.7	2000	4500	395	
MS54160XFA..	X FA	1500	56	357	3900	385	110	49	50.9	3700	4500	395	
MS54160XF3..	X F3	1700	60	337	3900	400	114	53	57.5	2100	4500	395	
MS54160XF1..	X F1	1900	64	322	3900	400	121	56	64.2	2200	4500	395	
MS54160XFC..	X FC	2300	67	278	3900	395	133	69	77.4	4500	4500	395	

MS180 - MS225 Series: 31 kW - 202 kW, 3 x 400 VAC (IP54)

Order Code	Motor	Code	Nominal speed nn [min ⁻¹]	Nominal power Pn [KW]	Nominal torque Tn [Nm]	Inertia J [kgcm ²]	Nominal voltage Vn [VRMS]	Nominal current In [ARMS]	Magnetising current Iμ [ARMS]	Nominal frequency Fn [Hz]	Max. speed at Pn Nmax1 [min ⁻¹]	Max. speed Nmax2 [min ⁻¹]	Weight W [kg]
MS54180ME3...	MS180	M E3	650	31	455	5050	395	58	24	22.4	1000	4 500	480
MS54180MEC...		M EC	900	42	446	5050	400	78	34	30.7	1200	4 500	480
MS54180MEA...		M EA	1000	46	439	5050	395	85	36	34.1	1700	4 500	480
MS54180MEB...		M EB	1350	59	417	5050	395	108	48	45.7	2400	4 500	480
MS54180MFB...		M FB	1500	64	407	5050	385	123	58	50.7	3900	4 500	480
MS54180MFA...		M FA	1800	73	387	5050	400	129	56	60.7	2300	4 500	480
MS54180MF2...		M F2	2300	83	345	5050	395	149	60	77.4	3600	4 500	480
MS54180MG1...		M G1	2600	86	316	5050	395	157	65	87.4	4200	4 500	480
MS54180PEB...		P EB	650	38	558	6300	395	73	30	22.6	1000	4 500	550
MS54180PE5...		P E5	850	49	550	6300	400	91	37	29.3	1000	4 500	550
MS54180PE1...		P E1	1000	57	544	6300	400	107	46	34.2	1300	4 500	550
MS54180PE2...		P E2	1250	69	527	6300	400	128	56	42.5	1600	4 500	550
MS54180PEA...		P EA	1500	80	509	6300	400	149	65	50.9	2000	4 500	550
MS54180PFA...		P FA	1800	91	483	6300	395	174	82	60.8	3400	4 500	550
MS54180PF1...		P F1	2250	100	424	6300	395	183	77	75.8	3700	4 500	550
MS54180PG1...		P G1	2600	105	386	6300	390	195	86	87.5	4500	4 500	550
MS54180XEC...		X EC	650	42	617	7300	390	82	36	22.6	1300	4000	600
MS54180XE4...		X E4	850	54	607	7300	400	100	43	29.3	1100	4000	600
MS54180XE3...		X E3	1000	63	602	7300	390	121	54	34.2	2100	4000	600
MS54180XEA...		X EA	1300	78	573	7300	390	149	67	44.2	2800	4000	600
MS54180XFB...	X FB	1500	88	560	7300	400	162	72	50.9	2000	4000	600	
MS54180XF1...	X F1	1800	99	525	7300	390	192	94	60.8	4000	4000	600	
MS54180XG1...	X G1	2500	110	420	7300	400	196	82	84.2	2800	4000	600	
MS54225SSE7...	MS225	S E7	650	46	676	10500	395	87	30	22.4	900	3 500	640
MS54225SEC...		S EC	850	58	652	10500	400	109	42	29.0	1100	3 500	640
MS54225SEA...		S EA	1000	67	640	10500	400	125	46	34.0	1300	3 500	640
MS54225SFB...		S FB	1300	82	602	10500	395	157	68	43.9	2400	3 500	640
MS54225SFA...		S FA	1500	93	592	10500	390	178	75	50.6	3100	3 500	640
MS54225SF1...		S F1	1800	105	557	10500	395	200	90	60.5	3500	3 500	640
MS54225SF2...		S F2	2100	116	527	10500	400	213	87	70.5	2900	3 500	640
MS54225LE3...		L E3	650	64	940	15000	385	125	48	22.3	1400	3 500	860
MS54225LE6...		L E6	850	81	910	15000	400	150	58	29.0	1100	3 500	860
MS54225LEC...		L EC	1000	94	898	15000	385	178	71	33.9	2400	3 500	860
MS54225LE2...		L E2	1300	116	852	15000	390	219	91	43.9	2800	3 500	860
MS54225LFA...		L FA	1500	130	828	15000	400	235	95	50.6	2100	3 500	860
MS54225LF1...		L F1	1800	142	753	15000	390	273	124	60.5	3500	3 500	860
MS54225XE3...		X E3	650	92	1352	21300	385	175	67	22.4	1600	3 500	1080
MS54225XE4...		X E4	850	117	1314	21300	395	214	82	29.0	1500	3 500	1080
MS54225XEB...		X EB	1000	135	1289	21300	385	252	99	34.0	2500	3 500	1080
MS54225XE1...		X E1	1300	166	1220	21300	400	300	126	44.0	1800	3 500	1080
MS54225XFA...		X FA	1500	184	1172	21300	400	333	143	50.6	2100	3 500	1080
MS54225XF1...		X F1	1750	202	1102	21300	395	371	164	58.9	3500	3 500	1080

MS280 Series: 143 kW - 342 kW, 3 x 400 VAC (IP54)

Order Code	Motor	Code	Nominal speed n _n [min ⁻¹]	Nominal power P _n [KW]	Nominal torque T _n [Nm]	Inertia J [kgcm ²]	Nominal voltage V _n [VRMS]	Nominal current I _n [ARMS]	Magnetising current I _μ [ARMS]	Nominal frequency F _n [Hz]	Max. speed at P _n N _{max1} [min ⁻¹]	Max. speed N _{max2} [min ⁻¹]	Weight W [kg]
MS54280MEA...	MS280	M EA	730	143	1870	39330	400	247	77	24.8	900	3 000	1290
MS54280ME1...		M E1	880	169	1834	39330	400	291	93	29.8	1100	3 000	1290
MS54280ME2...		M E2	1100	207	1797	39330	400	356	117	37.1	1400	3 000	1290
MS54280MF1...		M F1	1500	270	1719	39330	400	461	151	50.4	1900	3 000	1290
MS54280LEA...		L EA	590	140	2266	47250	400	244	79	20.1	700	3000	1520
MS54280LE1...		L E1	720	168	2228	47250	400	291	92	24.4	900	3000	1520
MS54280LE2...		L E2	900	206	2186	47250	400	356	118	30.4	1200	3000	1520
MS54280LF1...		L F1	1200	264	2101	47250	395	460	155	40.4	2100	3000	1520
MS54280XEA...		X EA	490	127	2475	56820	400	232	89	16.8	650	2800	1890
MS54280XE1...		X E1	600	153	2435	56820	400	277	104	20.4	750	2800	1890
MS54280XE2...		X E2	760	191	2400	56820	400	342	129	25.8	1000	2800	1890
MS54280XF1...		X F1	1020	248	2322	56820	400	444	173	34.4	1400	2800	1890
MS54280XF2...		X F2	1540	342	2121	56820	400	617	262	51.7	2200	2800	1890

Motor cooling fans

Motor	Cooling method	Voltage [V rms]	Current [Arms]	Noise [dB]	Voltage [Vrms]	Current [Arms]	Noise [dB]	Air flow [m ³ /h]	Pressure [mmH ₂ O]
		Frequency 50 Hz			Frequency 60 Hz				
MS 100	IP54-PVAP	345-440	0.19	66	345-460	0.12	70	220	12
MS 133	IP54-PVAP	345-480	0.34	74	345-480	0.31	78	720	17
MS 133	IP23-PVA	315-500	1.1	75	380-600	1.1	79	930	93
MS 160	IP54-PVAP	380-400	0.44	78	380-440	0.5	80	1100	21
MS 160	IP23-PVA	300-460	2.6	78	360-510	2.38	82	1300	125
MS 180	IP54/IP23-PVA	315-400	4.8	80	380-480	4.51	84	2200	120
MS 225	IP54/IP23-PVA	380-400	6.3	86	460-480	6.0	86	3300	315
MS 280	IP54/IP23-PVA	380-400	6.5	86	460-480	6.5	86	3900	285

Dimensions

MS100 - MS133 - MS160 - IP54 PVAP Cooling Configuration

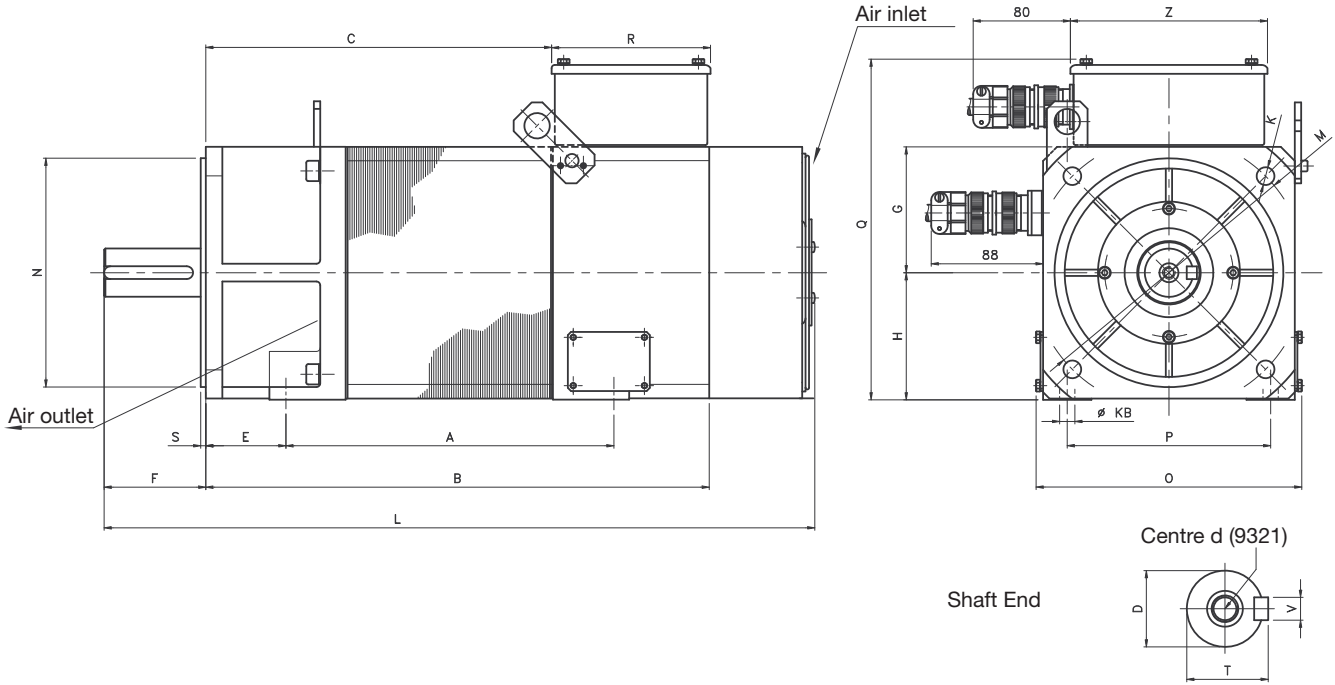

Motor		A	E	S	F	B	L	KB	P	O	M	K	H	G	Q	N	C	R	Z	D	T	V	d
MS100	S	198	63	4	80	336	500	12	160	209	215	14	100	99	268	180	212	125	155	38	41	10	M12
	M	258	63	4	80	396	560	12	160	209	215	14	100	99	268	180	272	125	155	38	41	10	M12
	L	318	63	4	80	456	620	12	160	209	215	14	100	99	268	180	332	125	155	38	41	10	M12
	P	378	63	4	80	516	680	12	160	209	215	14	100	99	268	180	392	125	155	38	41	10	M12
MS133	K	308	66	5	110	478	690	13	216	271	300	18	132	130	345	250	310	170	245	48	51.5	14	M16
	S	368	66	5	110	538	750	13	216	271	300	18	132	130	345	250	370	170	245	48	51.5	14	M16
	M	408	66	5	110	578	790	13	216	271	300	18	132	130	345	250	410	170	245	48	51.5	14	M16
	P	473	66	5	110	643	855	13	216	271	300	18	132	130	345	250	475	170	245	48	51.5	14	M16
MS160	M	402	108	5	110	642	872	14	254	327	350	18	160	158	400	300	473	170	245	55	59	16	M20
	L	482	108	5	110	722	952	14	254	327	350	18	160	158	400	300	553	170	245	55	59	16	M20
	P	552	108	5	110	792	1022	14	254	327	350	18	160	158	400	300	623	170	245	55	59	16	M20

MS133 - MS160 - MS180 PVA Cooling Configuration

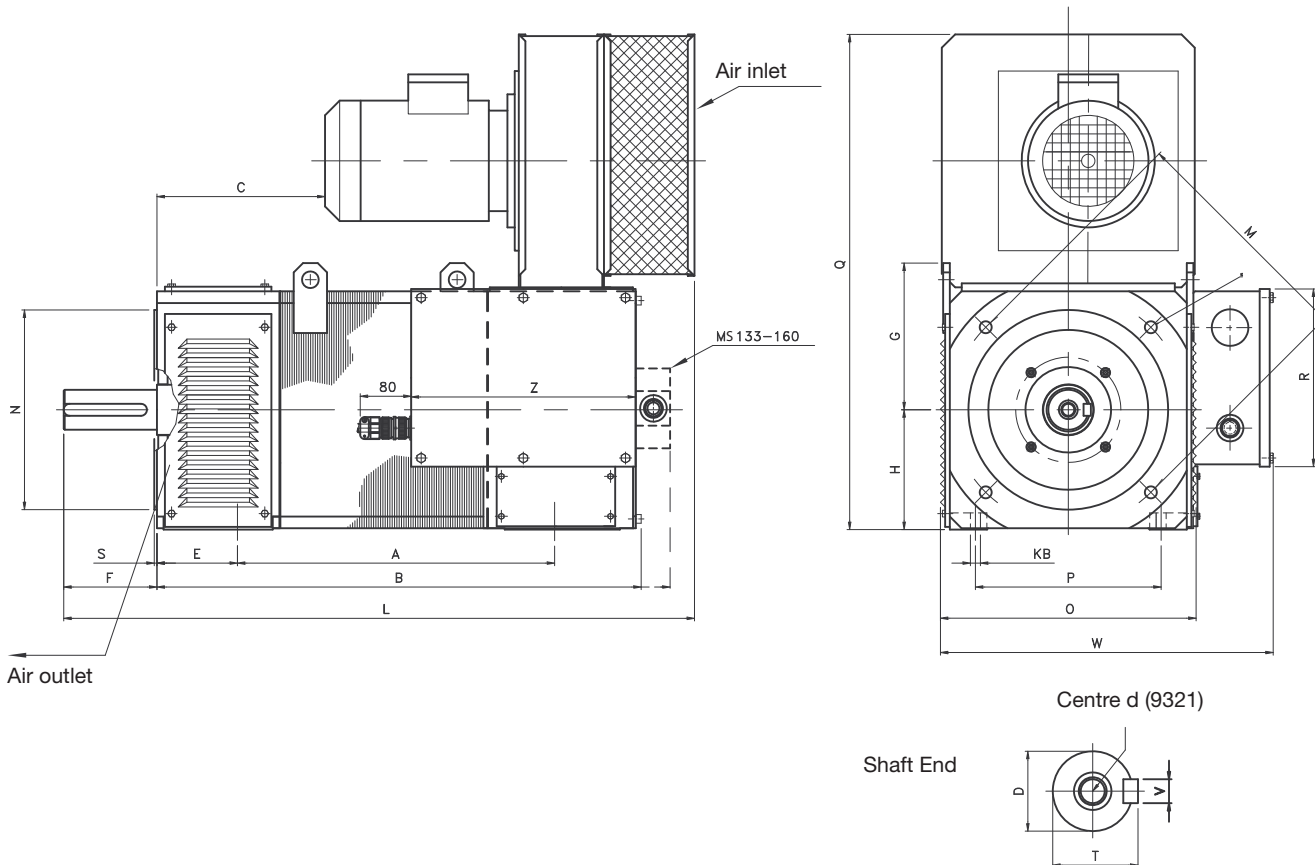

MS133 - MS160 - IP23 PVA Cooling Configuration

Motor		A	E	S	F	B	L	KB	P	O	M	K	H	G	Q	N	C	W	R	Z	D	T	V	d
MS133	K	308	66	5	110	508	646	13	216	294	300	18	132	182	523	250	101	367	170	245	48	51.5	14	M16
	S	368	66	5	110	568	706	13	216	294	300	18	132	182	523	250	161	367	170	245	48	51.5	14	M16
	M	408	66	5	110	608	746	13	216	294	300	18	132	182	523	250	201	367	170	245	48	51.5	14	M16
	P	473	66	5	110	673	811	13	216	294	300	18	132	182	523	250	266	367	170	245	48	51.5	14	M16
MS160	M	402	108	5	110	675	835	14	254	350	350	18	160	206	637	300	228	423	170	245	55	59	16	M20
	L	482	108	5	110	755	915	14	254	350	350	18	160	206	637	300	308	423	170	245	55	59	16	M20
	P	552	108	5	110	825	985	14	254	350	350	18	160	206	637	300	378	423	170	245	55	59	16	M20

MS180 IP23 & IP54 PVA Cooling Configuration

Motor		A	E	S	F	B	L	KB	P	O	M	K	H	G	Q	N	C	W	R	Z	D	T	V	d
MS180	M	567	121	5	140	816	1039	15	279	394	350	18	180	215	740	300	344	505	267	337	60	64	18	M20
	P	667	121	5	140	916	1139	15	279	394	350	18	180	215	740	300	444	505	267	337	60	64	18	M20

MS225 - MS280 - IP23 / IP54 PVA Cooling Configuration

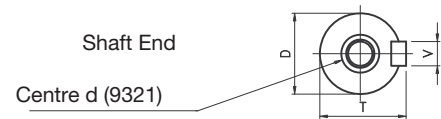
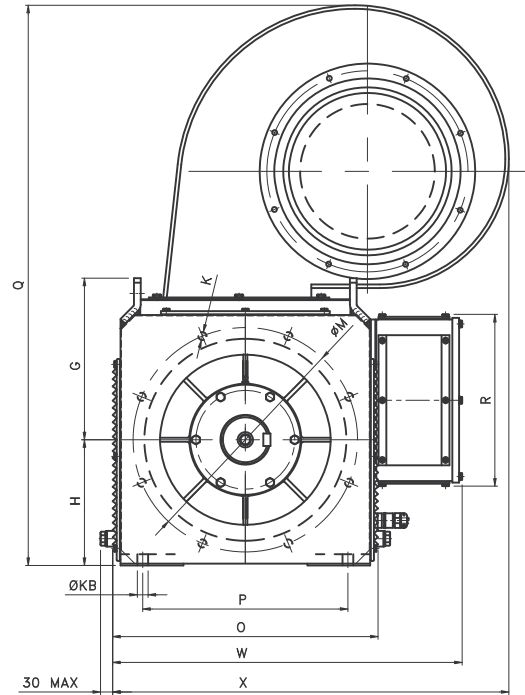
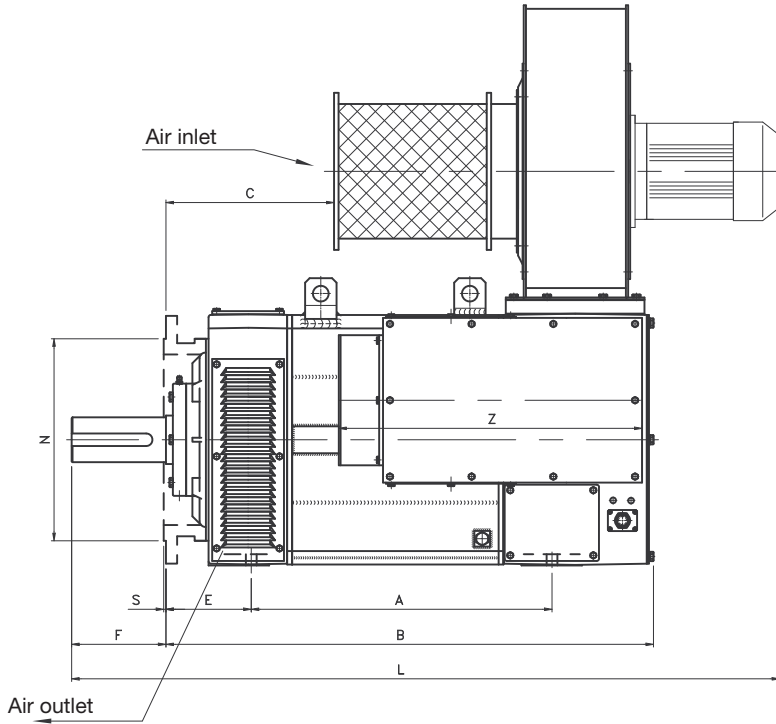

Motor	A	E	S	F	B	L	KB	P	O	M	K	H	G	Q	N	C	W	X	R	Z	D	T	V	d	
MS225	S	475	149	5	140	791	1203	19	356	482	400	18	225	272	1061	350	255	602	697	267	337	75	79.5	20	M20
	L	615	149	5	140	931	1343	19	356	482	400	18	225	272	1061	350	395	602	697	267	337	75	79.5	20	M20
	X	805	149	5	140	1121	1533	19	356	482	400	18	225	272	1061	350	585	602	697	267	337	75	79.5	20	M20
MS280	M	670	190	5	210	1086	1577	24	457	592	500	18	280	360	1248	450	375	780	882	383	676	100	106	28	M24
	L	770	190	5	210	1186	1677	24	457	592	500	18	280	360	1248	450	475	780	882	383	676	100	106	28	M24
	X	930	190	5	210	1346	1837	24	457	592	500	18	280	360	1248	450	635	780	882	383	676	100	106	28	M24

Order Code

MS Series Motors

	1		2	3	4		5	6		7	8	9	10		11
Order example	MS	-	23	100S	E1	-	1	B	-	R0	0	K	1	-	0000

1 Type of Motor

MS Square Frame Motor

2 IP Rating / Voltage

23 IP23 / 360V

24 IP23 / 460V

53 IP54 / 360V

54 IP54 / 460V

3 Motor Frame Size

100S Frame100S

100M Frame 100M

100L Frame 100L

100P Frame 100P

133S Frame 133S

133M Frame 133M

133P Frame 133P

133K Frame 133K

133X Frame 133X

160M Frame 160M

160L Frame 160L

160P Frame 160P

160X Frame 160X

180M Frame 180M

180P Frame 180P

180X Frame 180X

225S Frame 225S

225L Frame 225L

225X Frame 225X

280M Frame 280M

280L Frame 280L

280X Frame 280X

4 Windings/Speed

E1

E2

E3

E4

E5

E6 Refer to motor technical features to identify the required frame size and winding combination to suit your requirements

E7

E8

EA

EB

EC

ED

4 Windings/Speed (continued)

F1

F2

F3

F5

FA

FB

FC

FE

G1

G2

GA

GB

Refer to motor technical features to identify the required frame size and winding combination to suit your requirements

5 Mounting

1 Foot Mounting (B3)

2 Flange Mounting (B5)

3 Foot & Flange Mounting (B35)

6 Brake

0 Not Fitted

B Brake Fitted

7 Bearings/Rollers

R0 Standard Roller Bearings

RI Insulated Roller Bearings

BI Insulated Ball Bearings

8 Motor Shaft

0 Straight Shaft without Keyway

1 Straight Shaft with Keyway

9 Thermal Protection

K Klixon Protection

T Thermistor Protection

P PT100

10 Feedback Device

0 None

1 1024 PPR Encoder

2 2048 PPR Encoder

3 Resolver (45 kHz)

11 Special Options

0000 None

Round Frame Three-Phase Induction Motors - MR Series Motor 0.09 kW - 315 kW

Overview

Description

These IE2 efficiency round frame three-phase induction motors are suitable for use with the entire range of Parker variable speed AC drives. Featuring a durable rigid construction, these motors are specially engineered for use in heavy industrial applications. Featuring axial, In-Line force ventilation fan and optional 2048 ppr encoder, the round frame MR Series motor is suitable for general purpose open or closed-loop control applications. For higher dynamic performance, such as that required in printing or test rig applications, the MS series square frame vector motor should be considered.

- **Light aluminium body up to and including 160 frame size. Cast iron construction over 160 frame**
- **IP55 Protection as minimum**
- **Foot, flange, or foot and flange mounting options**
- **Insulation Class F (IEC - EN60034 -1)**
- **Auxiliary cooling fan allowing low-speed operation**
- **3x PTC thermistors embedded in motor stator as standard**
- **Holding brake or brake with hand release (Option)**
- **2048 ppr encoder (Option)**
- **2,4, or 6 poles (Option)**



Technical Characteristics - Overview

Motor type	Round Frame Three-Phase Induction Motor
Power range	0.09 kW ... 315 kW
Speed range	0 – 3000 min ⁻¹
Protection level	IP55
Insulation Class	F (IEC – EN600034 -1)
Feedback	Encoder (optional)
Suitable for drives	AC30V, AC690+, AC890, AC890PX-M

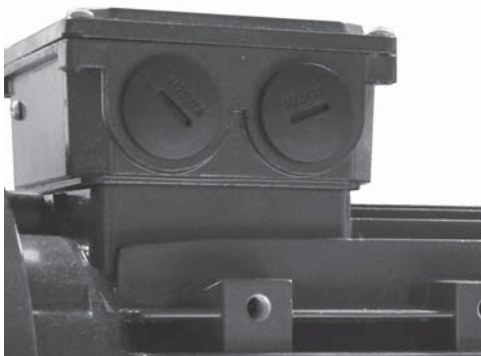

Generous motor terminal box for easy access

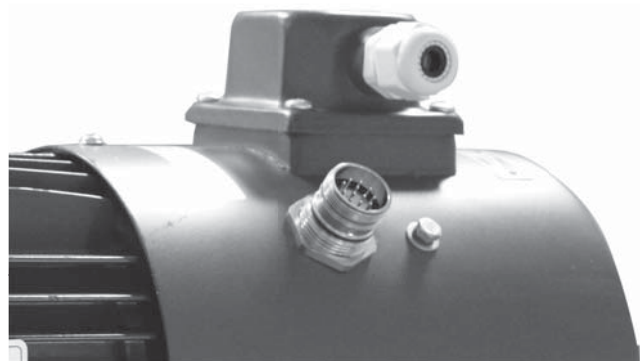

Simplified connection with a pre-wired encoder plug

Technical Features

MR Series: 2 Pole - 0.75 kW - 315 kW, 3 x 400 VAC

Order Code	Nominal Power P _n [kW]	Frame Size	Nominal speed n _n [min ⁻¹]	Full-load current at 400 V [A _{rms}]	Efficiency [%]	Power factor [cosφ]	Torque C _n [Nm]	I _s /I _n	C _s /C _n
MR2P00018...	0.18	TECA 563-2	2710	0.55	63	0.75	-	6	-
MR2P00025...	0.25	TECA 632-2	2710	0.71	65	0.78	-	6	-
MR2P00037...	0.37	TECA 633-2	2710	1.05	65	0.78	-	6	-
MR2P00055...	0.55	TECA 712-2	2760	1.42	71	0.79	-	6	-
MR2P00075...	0.75	MS2 801-2	2840	1.75	77.4	0.80	2.49	5.8	2.9
MR2P00110...	1.1	MS2 802-2	2850	2.42	80	0.82	3.53	6.8	3.5
MR2P00150...	1.5	MS2 90S-2	2850	3.20	81.4	0.83	5.09	6.9	3.5
MR2P00220...	2.2	MS290L-2	2860	4.54	83.2	0.84	7.32	7.9	4.1
MR2P00300...	3	MS2 100L-2	2880	5.88	84.6	0.87	9.96	7.8	3.4
MR2P00400...	4	MS2 112M-2	2890	7.54	86	0.89	13.16	7.5	2.7
MR2P00550...	5.5	MS2 132S1-2	2900	10.2	87.2	0.89	18.25	7.7	2.4
MR2P00750...	7.5	MS2 132S2-2	2910	13.8	88.1	0.89	24.47	8.4	2.6
MR2P01100...	11	MS2 160M1-2	2930	19.9	89.4	0.89	20.23	7.6	2.4
MR2P01500...	15	MS2 160M2-2	2930	26.9	90.3	0.89	27.68	8	2.6
MR2P01850...	18.5	MS2 160L-2	2940	32.6	90.9	0.90	33.42	9	3
MR2P02200...	22	T2C 180M-2	2930	39.08	91.3	0.89	71.70	7.5	2.3
MR2P03000...	30	T2C 200L1-2	2925	53.49	92	0.88	97.94	6.7	2.4
MR2P03700...	37	T2C 200L2-2	2930	64.15	92.5	0.90	120.59	6.3	2.3
MR2P04500...	45	T2C 225M-2	2930	79.45	92.9	0.88	146.66	6.9	2.3
MR2P05500...	55	T2C 250M-2	2940	96.80	93.2	0.88	178.64	8	2.3
MR2P07500...	75	T2C 280S-2	2940	125.45	93.8	0.92	243.60	8	2.2
MR2P09000...	90	T2C 280M-2	2940	150.06	94.1	0.92	292.33	7.7	2.2
MR2P11000...	110	T2C 315S-2	2940	187.08	94.3	0.90	357.29	7.7	2
MR2P13200...	132	T2C 315M-2	2940	221.33	94.6	0.91	428.74	7.6	2
MR2P16000...	160	T2C 315L1-2	2945	270.68	94.8	0.90	518.81	7.8	2
MR2P20000...	200	T2C 315L2-2	2945	341.44	95	0.89	648.51	7.9	2
MR2P25000...	250	T2C 355M-2	2945	422.05	95	0.90	810.64	7.8	2
MR2P31500...	315	T2C355L-2	2945	537.76	95	0.89	1021.40	7.8	2

Motors below 0.75 kW are not IE rated. For dimensions please contact your local sales office.

MR Series: 4 Pole - 0.75 kW - 315 kW, 3 x 400 VAC

Order Code	Nominal Power P _n [kW]	Frame Size	Nominal speed n _n [min ⁻¹]	Full-load current at 400 V [A _{rms}]	Efficiency [%]	Power factor [cosφ]	Torque C _n [Nm]	I _s /I _n	C _s /C _n
MR4P00012...	0.12	TECA 631-4	1360	0.55	52	0.64	-	4	-
MR4P00018...	0.18	TECA 632-4	1310	0.7	57	0.65	-	4	-
MR4P00025...	0.25	TECA 633-4	1340	0.91	60	0.66	-	4	-
MR4P00037...	0.37	TECA 712-4	1370	1.11	65	0.74	-	6	-
MR4P00055...	0.55	TECA 713-4	1380	1.6	66	0.75	-	6	-
MR4P00075...	0.75	MS2 802-4	1410	1.79	79.6	0.76	5.27	5.3	2.8
MR4P00110...	1.1	MS2 90S-4	1420	2.50	81.4	0.78	7.61	6.7	3.8
MR4P00150...	1.5	MS2 90L-4	1420	3.31	82.8	0.79	10.39	7.2	4
MR4P00220...	2.2	MS2 100L1-4	1440	4.83	84.3	0.78	14.76	7.4	3.6
MR4P00300...	3	MS2 100L2-4	1440	6.33	85.5	0.80	20.13	7.8	3.8
MR4P00400...	4	MS2 112M-4	1440	8.23	86.6	0.81	26.89	7.1	3.1
MR4P00550...	5.5	MS2 132S-4	1450	10.9	87.9	0.83	36.25	7.4	2.6
MR4P00750...	7.5	MS2 132M-4	1450	14.5	88.7	0.84	49.21	7.7	2.8
MR4P01100...	11	MS2 160M-4	1450	21.6	89.8	0.82	71.86	7.7	2.7
MR4P01500...	15	MS2 160L-4	1450	28.4	90.6	0.84	97.90	7.3	2.4
MR4P01850...	18.5	MS2 180M-4	1460	34.4	91.4	0.85	121.32	7.4	2.2
MR4P02200...	22	T2C 180L-4	1460	38.95	91.6	0.89	143.89	7.5	2.3
MR4P03000...	30	T2C 200L-4	1460	53.31	92.3	0.88	196.22	7.9	2.4
MR4P03700...	37	T2C 225S-4	1470	72.02	92.7	0.80	240.36	6.7	2.4
MR4P04500...	45	T2C 225M-4	1480	87.21	93.1	0.80	290.35	7	2.3
MR4P05500...	55	T2C 250M-4	1480	96.49	93.5	0.88	354.87	7.4	2.4
MR4P07500...	75	T2C 280S-4	1480	126.56	94.0	0.91	483.92	7.5	2.2
MR4P09000...	90	T2C 280M-4	1480	149.90	94.2	0.92	580.70	7.7	2.25
MR4P11000...	110	T2C 315S-4	1480	186.69	94.5	0.90	709.75	7.8	2
MR4P13200...	132	T2C 315M-4	1480	221.09	94.7	0.91	851.69	7.8	2
MR4P16000...	160	T2C 315L1-4	1480	267.43	94.9	0.91	1032.36	7.9	2
MR4P20000...	200	T2C 315L2-4	1480	337.29	95.1	0.90	1290.45	7.7	2
MR4P25000...	250	T2C 355M-4	1480	426.35	95.1	0.89	1613.06	7.9	2
MR4P31500...	315	T2C355L-4	1480	531.23	95.1	0.90	2032.45	7.8	2

Motors below 0.75 kW are not IE rated. For dimensions please contact your local sales office.

MR Series: 6 Pole - 0.75 kW - 250 kW, 3 x 400 VAC

Order Code	Nominal Power P _n [kW]	Frame Size	Nominal speed n _n [min ⁻¹]	Full-load current at 400 V [Arms]	Efficiency [%]	Power factor [cosφ]	Torque C _n [Nm]	Is/In	Cs/Cn
MR6P00009...	0.09	TECA 631-6	840	0.51	42	0.61	-	3.5	
MR6P00012...	0.12	TECA 632-6	850	0.62	45	0.62	-	3.5	-
MR6P00018...	0.18	TECA 711-6	880	0.70	56	0.66	-	4	-
MR6P00025...	0.25	TECA 712-6	900	0.87	59	0.7	-	4	-
MR6P00037...	0.37	TECA 713-6	890	1.27	61	0.69	-	6	-
MR6P00055...	0.55	TECA 802-6	900	1.65	67	0.72	-	6	-
MR6P00075...	0.75	MS2 90S-6	925	2.01	76.0	0.71	7.75	4.7	3.1
MR6P00110...	1.1	MS2 90L-6	930	2.82	78.1	0.72	11.43	5	3.2
MR6P00150...	1.5	MS2 100L-6	940	3.71	80.0	0.73	15.09	5.9	3.1
MR6P00220...	2.2	MS2 112M-6	945	5.17	81.8	0.75	22.13	5.5	2.6
MR6P00300...	3	MS2 132S-6	960	6.84	83.3	0.76	30.32	5.7	2.2
MR6P00400...	4	MS2 132M1-6	960	8.86	84.6	0.77	41.25	6.2	2.4
MR6P00550...	5.5	MS2 132M2-6	960	12.0	86	0.77	54.86	6.7	2.6
MR6P00750...	7.5	MS2 160M-6	970	16.1	87.5	0.77	74.69	5.6	2
MR6P01100...	11	MS2 160L-6	970	22.9	89.0	0.78	108.92	5.8	2
MR6P01500...	15	MS2 180L-6	975	28.9	90.1	0.83	147.77	7.5	1.9
MR6P01850...	18.5	MS2 200L1-6	975	35.6	90.4	0.83	180.32	6.3	2.2
MR6P02200...	22	T2C 200L2-6	965	40.62	90.9	0.86	217.70	7.9	2.3
MR6P03000...	30	T2C 225M-6	975	55.56	91.7	0.85	293.82	7.9	2.2
MR6P03700...	37	T2C 250M-6	975	69.79	92.2	0.83	362.38	7.5	2.3
MR6P04500...	45	T2C 280S-6	980	81.48	92.7	0.86	438.49	7.2	2.3
MR6P05500...	55	T2C280M1-6	980	99.15	93.1	0.86	535.93	7.7	2.2
MR6P07500...	75	T2C 315S-6	980	129.81	93.7	0.89	730.81	7.9	2.1
MR6P09000...	90	T2C 315M-6	980	153.56	94	0.90	876.98	7.9	2
MR6P11000...	110	T2C 315L1-6	980	187.08	94.3	0.90	1071.86	7.7	2
MR6P13200...	132	T2C 315L2-6	980	226.30	94.6	0.89	1286.23	7.8	2
MR6P16000...	160	T2C 355M1-6	980	267.71	94.8	0.91	1559.07	7.8	2
MR6P20000...	200	T2C 355M2-6	980	337.64	95	0.90	1948.84	7.8	2
MR6P25000...	250	T2C 355L-6	980	426.79	95	0.89	2436.06	7.8	2

Motors below 0.75 kW are not IE rated. For dimensions please contact your local sales office.

Dimensions

MR Series Frames MS2

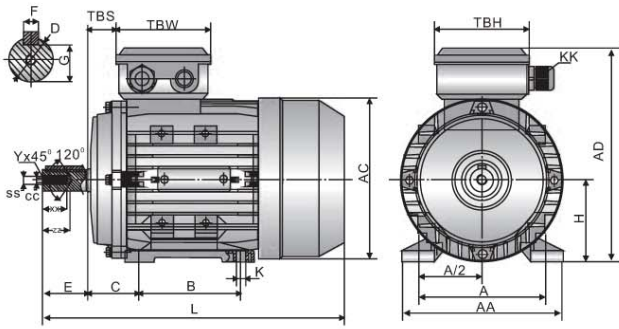

B3 Mounting

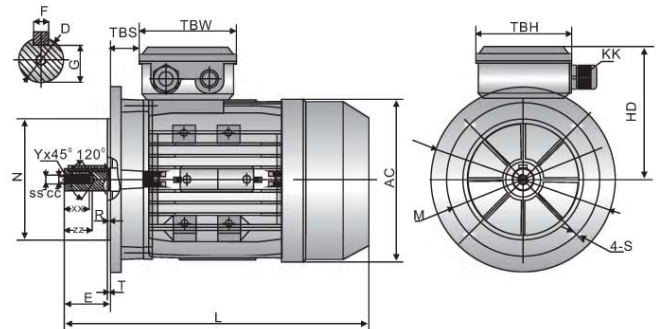

B5 Mounting

Frame MS2	B3 Foot Mounting					Shaft								General							
	H	A	B	C	K	D	E	F	G	SS	XX	ZZ	AA	AD	HD	AC	L	KK	TBS	TBW	TBH
56	56	90	71	36	5.8x8.8	ø9	20	3	7.2	M3	9	12	110	156	100	ø117	196	1-M16x1.5	14	88	88
63	63	100	80	40	7x10	ø11	23	4	8.5	M4	10	14	120	171	108	ø130	220	1-M16x1.5	14	94	94
71	71	112	90	45	7x10	ø14	30	5	11	M5	12	17	132	186	115	ø147	241	1-M20x1.5	20	94	94
80	80	125	100	50	10x13	ø19	40	6	15.5	M6	16	21	160	213	133	ø163	290	1-M20x1.5	27	105	105
90S	90	140	100	56	10x13	ø24	50	8	20	M8	19	25	175	229	139	ø183	312	1-M20x1.5	30	105	105
90L1/L2	90	140	125	56	10x13	ø24	50	8	20	M8	19	25	175	229	139	ø183	337/367	1-M20x1.5	30	105	105
100	100	160	140	63	12x15	ø28	60	8	24	M10	22	30	198	252	152	ø205	369	2-M20x1.5	26	105	105
112	112	190	140	70	12x15	ø28	60	8	24	M10	22	30	220	279	167	ø229	395	2-M25x1.5	32	112	112
132S	132	216	140	89	12x15	ø38	80	10	33	M12	28	37	252	318	186	ø265	437	2-M25x1.5	38	112	112
132M/L	132	216	178	89	12x15	ø38	80	10	33	M12	28	37	252	318	186	ø265	475/501	2-M25x1.5	38	112	112
160M/L	160	254	210/254	108	15x19	ø42	110	12	37	M16	36	45	290	384	224	ø325	640	2-M32x1.5	64	143	143
180M/L	180	279	241/279	121	15x25	ø48	110	14	42.5	M18	36	45	340	440	260	ø368	730	2-M32x1.5	73	190	190
200L	200	318	305	133	19x29	ø55	110	16	49	M20	42	53	390	460	260	ø368	745	2-M32x1.5	85	190	190

Frame MS2	B5 Flange Mounting					
	M	N	P	T	S	R
56	ø100	ø80	ø120	3.0	ø7	0
63	ø115	ø95	ø140	3.0	ø10	0
71	ø130	ø110	ø160	3.5	ø10	0
80	ø165	ø130	ø200	3.5	ø12	0
90S	ø165	ø130	ø200	3.5	ø12	0
90L1/L2	ø165	ø130	ø200	3.5	ø12	0
100	ø215	ø180	ø250	4.0	ø15	0
112	ø215	ø180	ø250	4.0	ø15	0
132S	ø265	ø230	ø300	4.0	ø15	0
132M/L	ø265	ø230	ø300	4.0	ø15	0
160M/L	ø300	ø250	ø350	5.0	ø19	0
180M/L	ø300	ø250	ø350	5.0	ø19	0
200L	ø350	ø300	ø400	5.0	ø19	0

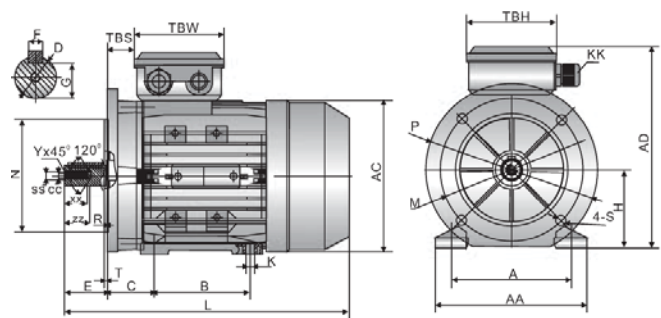

B55 Mounting

For Dimensions of Motors below 0.75 kW please contact your local sales office.

MR Series Frames T2C

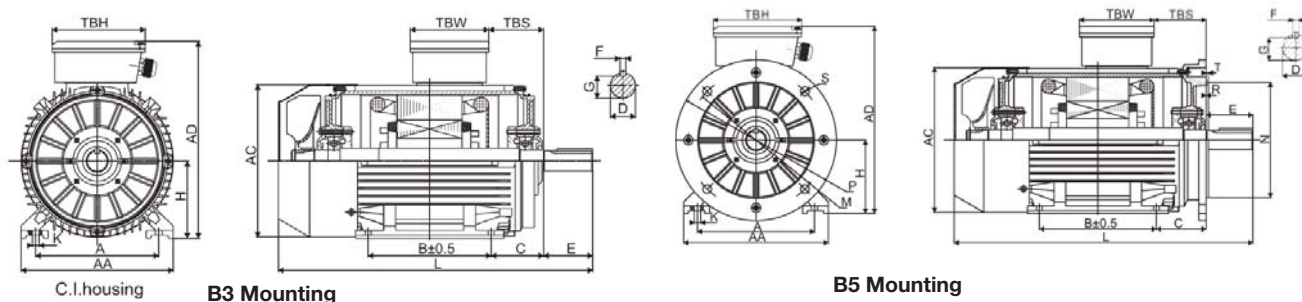

Frame T2C	B3 Foot Mounting				Shaft					General							
	H	A	B	C	D	E	F	G	K	AA	AD	HD	AC	L	TBS	TBW	TBH
180M/L	180	279	241/279	121	ø48	110	14	42.5	ø15	348	439	259	360	687/725	160/180	162	187
200L	200	318	305	133	ø55	110	16	49	ø19	388	497	297	399	768	192	186	233
225S	225	356	286	149	ø60	140	18	53	ø19	436	553	328	465	814	190	186	233
225M	2 Pole	225	356	311	ø55	110	16	49	ø19	436	553	328	456	809	202	186	233
	4,6 Pole	225	356	311	ø60	140	18	53	ø19	436	553	328	465	839	202	186	233
250M	2 Pole	250	406	349	ø60	140	18	53	ø24	484	616	366	506	918	233	218	260
	4,6 Pole	250	406	349	ø65	140	18	58	ø24	484	616	366	506	918	233	218	260
280S/M	2 Pole	280	457	368/419	ø65	140	18	58	ø24	557	668	388	559	984/1035	265	218	260
	4,6 Pole	280	457	368/419	ø75	140	20	67.5	ø24	557	668	388	559	984/1035	265	218	260
315S	2 Pole	315	457	406	ø65	140	18	58	ø28	630	845	530	680	1205	130	280	320
	4,6 Pole	315	508	406	ø80	170	22	71	ø28	630	845	530	680	1235	130	280	320
315M/L	2 Pole	315	508	457/508	ø65	140	18	58	ø28	630	845	530	680	1355	130	280	320
	4,6 Pole	315	508	457/508	ø80	170	22	71	ø28	630	845	530	680	1385	130	280	320
355M/L	2 Pole	355	610	560/630	ø75	140	20	67.5	ø28	740	1010	655	820	1500	HO	330	380
	4,6 Pole	355	610	560/630	ø100	210	28	90	ø28	740	1010	655	820	1570	140	330	380

Frame T2C	B5 Flange Mounting						
	N	M	P	S	T	R	
180M/L	250	300	350	4-ø19	5	0	
200L	300	350	400	4-ø19	5	0	
225S	350	400	450	8-ø19	5	0	
225M	2 Pole	350	400	450	8-ø19	5	0
	4,6 Pole	350	400	450	8-ø19	5	0
250M	2 Pole	450	500	550	8-ø19	5	0
	4,6 Pole	450	500	550	8-ø19	5	0
280S/M	2 Pole	450	500	550	8-ø19	5	0
	4,6 Pole	450	500	550	8-ø19	5	0
355M/L	550	600	660	8-ø24	6	0	

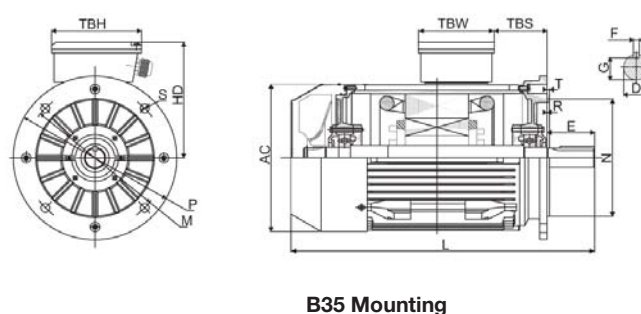

For Dimensions of Motors below 0.75 kW please contact your local sales office.

Auxiliary Fans

All frame sizes can be supplied with cooling system IC416 (forced ventilation). In this case a suitable fan is fitted inside the fan cover and suitably reinforced. We always recommend forced ventilation on motors used below 25 Hz or above 75 Hz. Consequently the ventilation is independant of the rotation speed of the motor itself.

Frame Size	Three Phase Supply Voltage [VAC]	Supply Frequency [Hz]	Input Power [W]	Single Phase Supply Voltage [VAC]	Supply Frequency [Hz]	Input Power [W]	Overall length L (increasing) [mm]
63	230/400	50	20	230	50	17	92
71	230/400	50	25	230	50	33	92
80	230/400	50	29	230	50	35	98
90	230/400	50	32	230	50	45	97
100	230/400	50	58	230	50	30	103
112	230/400	50	69	230	50	35	93
132	230/400	50	52	230	50	32	109
160	230/400	50	70	230	50	50	145
180	230/400	50	85	230	50	47	130
200	230/400	50	105	230	50	49	140
225	230/400	50	105	230	50	70	160
250	230/400	50	115	230	50	126	167
280	230/400	50	180	230	50	149	175
315	230/400	50	480	230	50	-	205
355	230/400	50	400	230	50	-	205

When an encoder is mounted with the ventilation option, dimension L does not change and remains the same as the motor with independant ventilation.

Order Code

MR Series Motors

	1		2	3		4	5		6	7	8	9	10		11
Order example	MR	-	2P	00018	-	1	B	-	R	1	T	1	1	-	0000

1	Type Of Motor (mandatory field)
MR	Round Frame Motor
2	Motor Type
2P	2 Pole
4P	4 Pole
6P	6 Pole
3	Motor Rating
00009	0.09 kW (6 Pole only)
00012	0.12 kW (not available as 2 Pole)
00018	0.18 kW
00025	0.25 kW
00037	0.37 kW
00055	0.55 kW
00075	0.75 kW
00110	1.1 kW
00150	1.5 kW
00220	2.2 kW
00300	3 kW
00400	4 kW
00550	5.5 kW
00750	7.5 kW
01100	11 kW
01500	15 kW
01850	18.5 kW
02200	22 kW
03000	30 kW
03700	37 kW
04500	45 kW
05500	55 kW
07500	75 kW
09000	90 kW
11000	110 kW
13200	132 kW
16000	160 kW
20000	200 kW
22000	220 kW
25000	250 kW
28000	280 kW (not available as 6 Pole)
31500	315 kW (not available as 6 Pole)

4	Mounting
1	Foot Mounting (B3)
2	Flange Mounting (B5)
3	Floot & Flange Mounting (B35)
5	Brake
0	Not Fitted
B	Brake Fitted
H	Hand Brake Fitted
6	Bearings/Rollers
B	Bearings
R	Rollers
7	Force Ventilation Fan
0	None
1	Single Phase
2	Three Phase
8	Protection (mandatory field)
T	Thermistors
9	Feedback Device
0	None
1	2048 ppr Encoder
10	IP Rating (mandatory field)
1	IP55
11	Special Options
0000	None

Sensorless Servo Motors - NX Series

Overview

Description

The sensorless version of NX Series Servo Motors has been designed to offer a cost effective brushless solution when used in conjunction with AC drives. Controlled without feedback sensor, NX Series servomotors are innovative, compact, high performance and extremely efficient alternative to traditional induction motors.

Features and Benefits

- Cost effective brushless solution
- Sensorless control with AC drives
- More compact and efficient than induction motors
- More robust design due to the lack of feedback sensor
- No need for cooling fan



Technical Characteristics - Overview

Motor type	Permanent magnet synchronous servomotors	
Rotor design	Rotor with concentrated-flux rare earth magnets	
Number of poles	10	
Power range	0.21...7.5 kW	
Torque range	0.45 - 41 Nm	
Speed range	6000 min ⁻¹	
Protection level (IEC60034-5)	<ul style="list-style-type: none"> • IP64 (standard) • IP65 (option) 	
Marking	CE	UL
Voltage supply	230 / 400 VAC	230 / 480 VAC
Temperature class (IEC60034-1)	<ul style="list-style-type: none"> • Class F 	<ul style="list-style-type: none"> • Class A (NX1 – 2) • Class F (NX3 – 8)
Connections	<ul style="list-style-type: none"> • Connectors (option) • Terminal box (standard) 	<ul style="list-style-type: none"> • Connectors (NX1 – 8)

Torque Motors - TMW Series

Overview

Description

Parker Torque motor is an innovative direct drive solution designed for industrial applications requiring high torque at low speed without any additional mechanical transmission system. Their usage results in more compact, more efficient, quieter and virtually maintenance free drive systems.

Parker torque motors are permanent magnet brushless servo motors, with a high number of poles, able to deliver torques up to 22 000 Nm at speeds up to 500 min⁻¹.

Especially designed to replace direct current or induction motors and gearboxes, they offer specific features such as built-in thrust bearing or patent pending screw extraction mechanisms, making them particularly suitable for applications in segments such as plastics and rubber extrusion, injection molding, etc. Basic versions of TM Torque Motors can also be used in many other similar applications such as winders, crushers, mixers, and more generally in all application segments requiring framed torque motors operated in speed control.

Example of energy savings

Removal of the gearbox has an immediate impact on the overall installation's efficiency, resulting in energy savings.

Example

- 100 kW extruder
- 7200 h annual operating
- Energy cost: 0.10 €/kWh

Overall efficiency improvement due to the installation of a torque motor: 5 %

Annual savings 3600 €

Features

- High power compact design
- Water or natural cooling
- Overtemperature protection built in
- Wide range of feedback devices
- Integrated thrust bearing
- Customizable shaft ends
- IP54 protection
- IM B3 or IM B34 mounting



Technical Characteristics - Overview

Torque range	1200...22 100 Nm (water-cooling)
Shaft heights	200, 315, 400 mm
Rated Voltage	400 VAC and 480 VAC
Speed	<ul style="list-style-type: none"> • 50...500 min⁻¹ (size dependent) • Field weakening operation up to 1.2 x n_{rated} • Other speeds available on request
Cooling	<ul style="list-style-type: none"> • Water Jacket as standard • Natural ventilation with derating (consult us)
Mounting	IM B3 or IM B34
Protection degree	IP54
Thermal protection	<ul style="list-style-type: none"> • 1x KTY sensor and 2x PTC probes • Temperature alarm and default
Shaft end	<ul style="list-style-type: none"> • Solid or hollow shaft with key, keyway, spline profile • Customized interfaces available on request
Bearing	<ul style="list-style-type: none"> • Roller bearing • Ball bearing • Thrust bearing (SKF 294__E)
Feedback sensor	<ul style="list-style-type: none"> • EnDat Encoder (standard) • Direct EnDat Encoder with hollow shaft (option) • Resolver (option)

FASTPACK

Packaged AC Drive Solutions 0.25 - 900 kW

FASTPACK is a range of single and three phase industrial drives designed to provide a simple packaged solution across a wide range of variable and constant torque applications up to 900 kW.

Designed as a simple replacement to direct-on-line, star/delta or soft start control of motors, they can be configured to deliver complete control in a single ready-to-install robust industrial enclosure.

A multitude of pre-engineered, coded control options enable the FASTPACK range to be offered on short deliveries at very economical cost.

Control options such as operator keypad, start/stop pushbuttons, emergency-stops and output contactors can all be selected from a list of standard options. Integration into existing systems can be achieved through the use of one of the many fieldbus or encoder options that are also available.

Features:

- Pre-coded control options
- CE Marked to EN60204 and ISO EN13849
- NRTL approval for North America and Canada possible
- Pre-engineered solution
- No engineering costs
- Fast Delivery
- Ready to install

Example Applications

Hydraulic Pump Control:

Improved efficiency in hydraulic systems with electronic control technologies.

The AC10 standard FASTPACK has been supplied for control in numerous hydraulic pump applications. By reducing the motor speed during low flow demand or pressure holding parts of the machine cycle, significant energy savings can be achieved. This example is a 15kW FASTPACK used in an accumulator charging application. This packaged drive was delivered in 10 days and commissioned in a single day.



Water Pump Control:

70 % Energy savings and improved reliability

11 kW FASTPACK supplied for decentralised water pump control for the stock preparation in a paper mill. The drive was designed to replace a direct on-line (DOL) starter and was supplied in 10 days. Reducing the pump speed to match the process demand delivered an average energy saving of 70 %. This also reduced stress on the mechanical components in the system during starting, leading to improved reliability.



Extruder Control:

Drive controls update delivers improved performance.

55 kW Advance Performance AC30 FASTPACK supplied to an end user for use in a plastic extruder application. Simple, easy to use door mounted controls matched with the advanced functionality of the AC30 delivered a drive control system upgrade to improve overall machine control and productivity.



Standard AFE Regenerative Solutions:





The simple route to compliance with the power generation regulations.

90 kW 4 quadrant Active Front End (AFE) supplied to an OEM customer involved in delivering small scale renewable energy solutions.

The AFE solution allows energy generated by renewables to be synchronised with, and exported to the supply network. The system meets all of the relevant statutory supply regulations out of the box, removing the headache of compliance from the customer.



Step 1: Define your application level

FASTPACK	Power [kW]	Details	Image	Typical Applications											
				Pumps	Hydraulic pumps	Fans	Air compressor	Conveyors	Mixers / Agitators	Extruders	Crushers	Renewables	Dynamometers/Test Rigs		
Compact	0.25 to 22	The integrated AC10 Series Compact drive provides easy to use, out of the box control for simple motor speed control applications.		●	●			●	●						
Standard	1.1 to 75	The AC30 Series AC drive offers the functionality of flux vector and closed loop control along with integrated application specific software macros.		●	●	●	●	●	●	●	●				
High Performance	1.1 to 400	Making use of the high performance AC890 drive to provide high levels of speed and position control of open- and closed-loop AC or servo motor applications.			●					●	●				
High Power	110 to 900	The AC890PX Modular Chassis provides an effective way of managing high power applications up to 900 kW. Its modularity assures the lowest possible cost of ownership.									●	●		●	
Active Front End	11 to 400	Packaged 4 Quadrant regenerative solution suitable for simple renewable energy applications offering unity power factor with a very low harmonic current content (THD <5 %)												●	●

Step 2: Select your control options

Operator Controls

After selecting your FASTPACK application level, a range of standard operator control options can be selected to manage the following operations:

- **Start/Stop control**
- **Direction control**
- **Inch control**
- **Speed control**
- **Speed and load meters**
- **Emergency stop**

A range of operator devices including digital and analogue panel meters, multi-turn potentiometers, local/remote pushbuttons, selector or key switches and indicator lamps can be provided to create the required level of operator interface for your application.



Control Equipment

FASTPACK systems are frequently used for more complex machine or process control. As a result, a comprehensive selection of auxiliary control equipment is available to facilitate the drive's integration into the system. These include:

- **Motor output contactor**
- **Additional EMC filter**
- **Door interlocked isolator and MCBs**
- **Emergency stop relay**
- **110 VAC or 240 VAC Control transformer**
- **Input harmonic chokes**
- **Output chokes**
- **24 VDC Power supplies**
- **Stainless steel enclosure**
- **Industrial fieldbus communications**
- **Customer options available on request**



Step 3: Create your complete product code

Code Toolbox

The code toolbox software guides you through a step-by-step process to quickly and easily take your application requirements and convert them into a FASTPACK packaged drive solution that meets all of your needs. The software shows you exactly what your packaged drive will look like and also creates the full product order code.

The Code Toolbox can be found at:
www.parker.com/ssd/fastpack

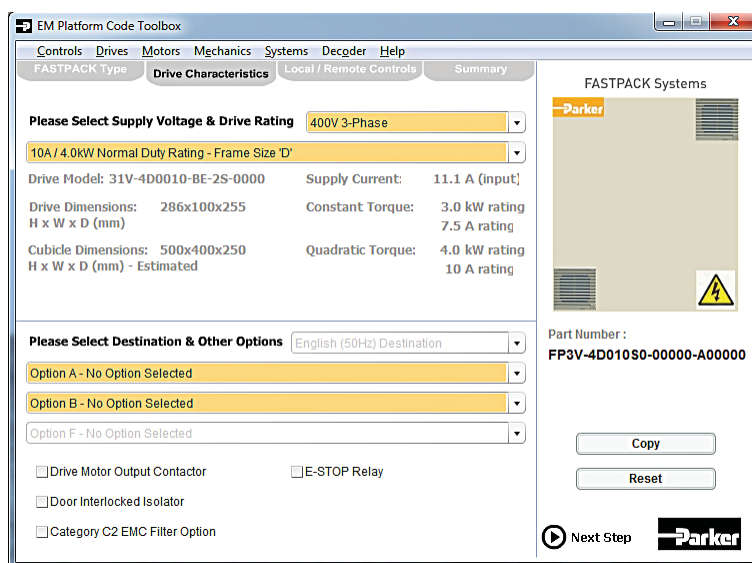

Bespoke Drive Systems

For applications requiring greater control, or multiple drives mounted in the same enclosure, we are able to offer a complete, engineered, packaged drive system.

These turnkey systems enable you to concentrate on your core business while leaving Parker to deal with all aspects of the design, build, programming, installation and commissioning of your motor and machine control.



Parker's Drive Systems Build Capabilities

Engineered Solutions

Systems Build Capabilities

For customers requiring more support in the design and implementation of their control systems, Parker offers a complete in-house design and build service, enabling you to focus on your core competencies. Based on the fundamental principles of application expertise, quality, reliability and safety, Parker's systems team is able to undertake all aspects of an electrical control system project, from pre-design specification to on-site installation and cabling services. By partnering with Parker to undertake the design, build, programming and commissioning of your motor control system, you can be assured that every aspect of the design, from environmental considerations through component selection to mounting of products

has been carefully considered and allowed for. Fully documenting a complete control system can be a daunting task for many equipment manufacturers, again Parker are on hand to help by providing complete electrical schematic and single line drawings as well as installation, maintenance and operating instructions. As an accredited systems builder, Parker is also able to undertake the certification process required to enable systems to be put into service in any number of industrial markets.

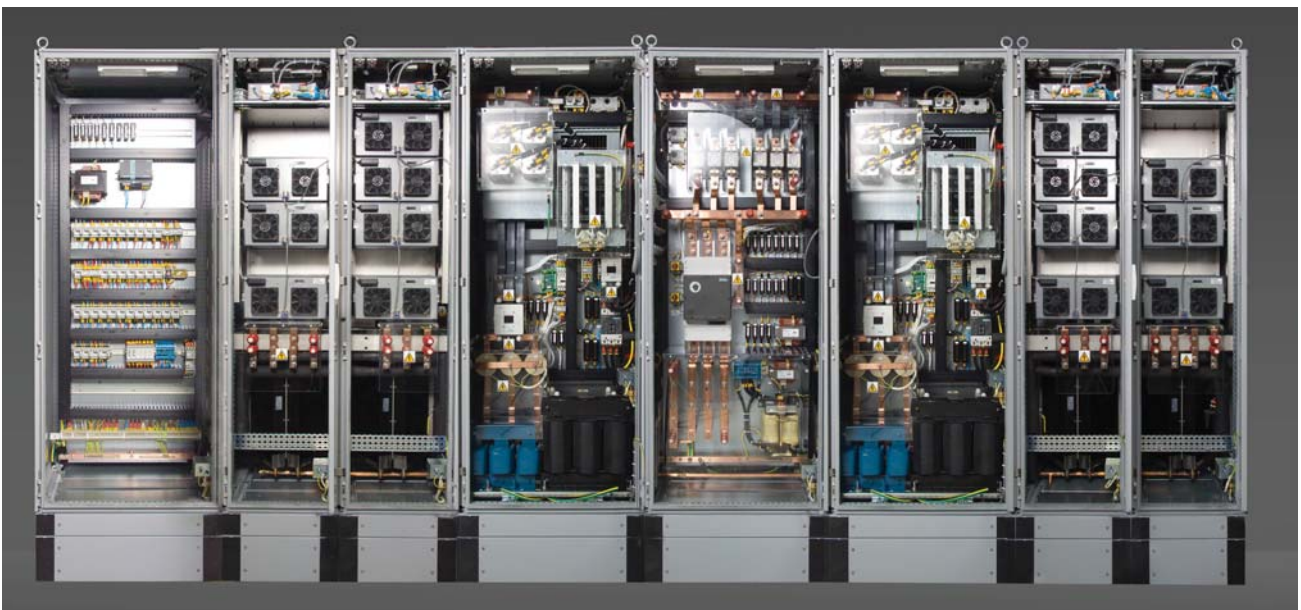

Total Project Support

From concept to installation and beyond, Parker has a full range of complimentary capabilities to provide as much or as little support to your own team's expertise as you need. With a team of highly qualified and experienced design, build and service engineers, we take the risk out of any capital project by ensuring that all stages of the project are managed and executed precisely to your requirements.

Holding certification to the latest quality standards (ISO 9001-2008) means that as a customer, you can be assured of reliable, repeatable quality of design, build and documentation.

Please Note: Service and support offers vary by country. Please contact your local sales office shown on the back cover to check if a particular service is available in your country.

Example Packaged Drive Systems Renewable Energy Power Conversion

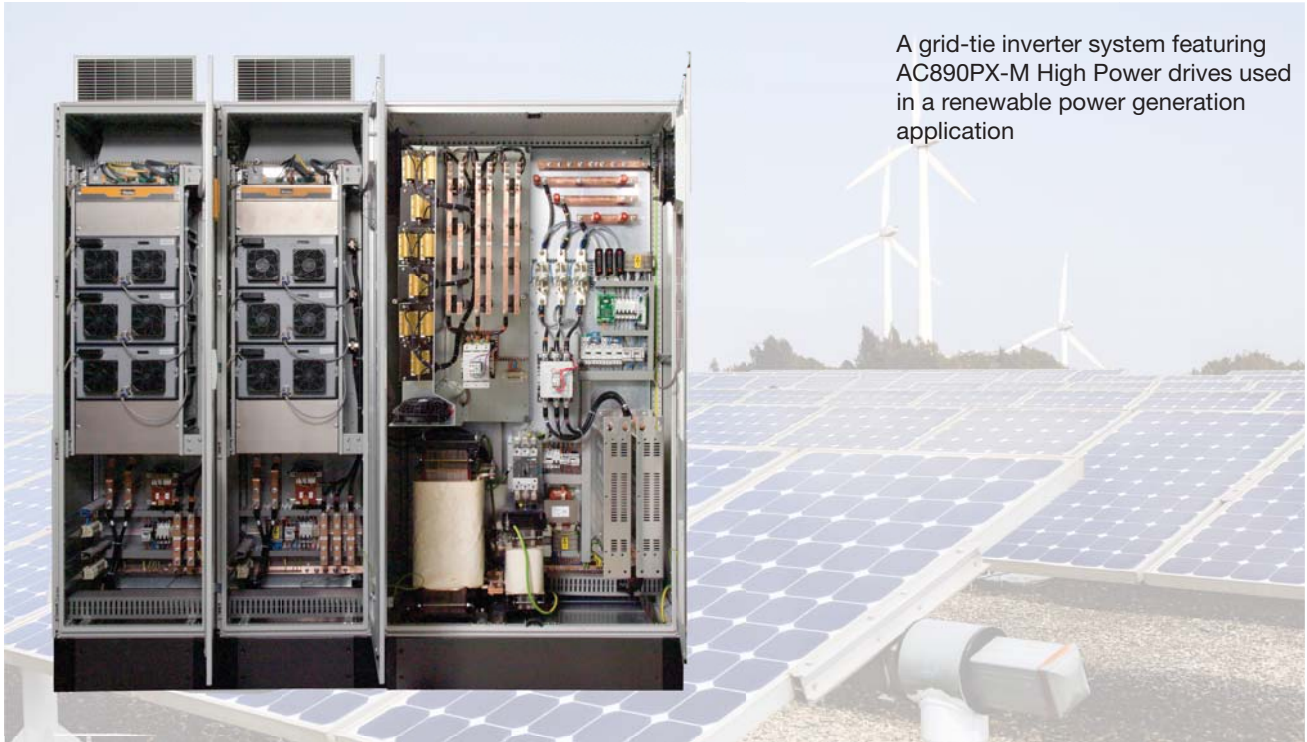

A grid-tie inverter system featuring AC890PX-M High Power drives used in a renewable power generation application

Marine Test Rig

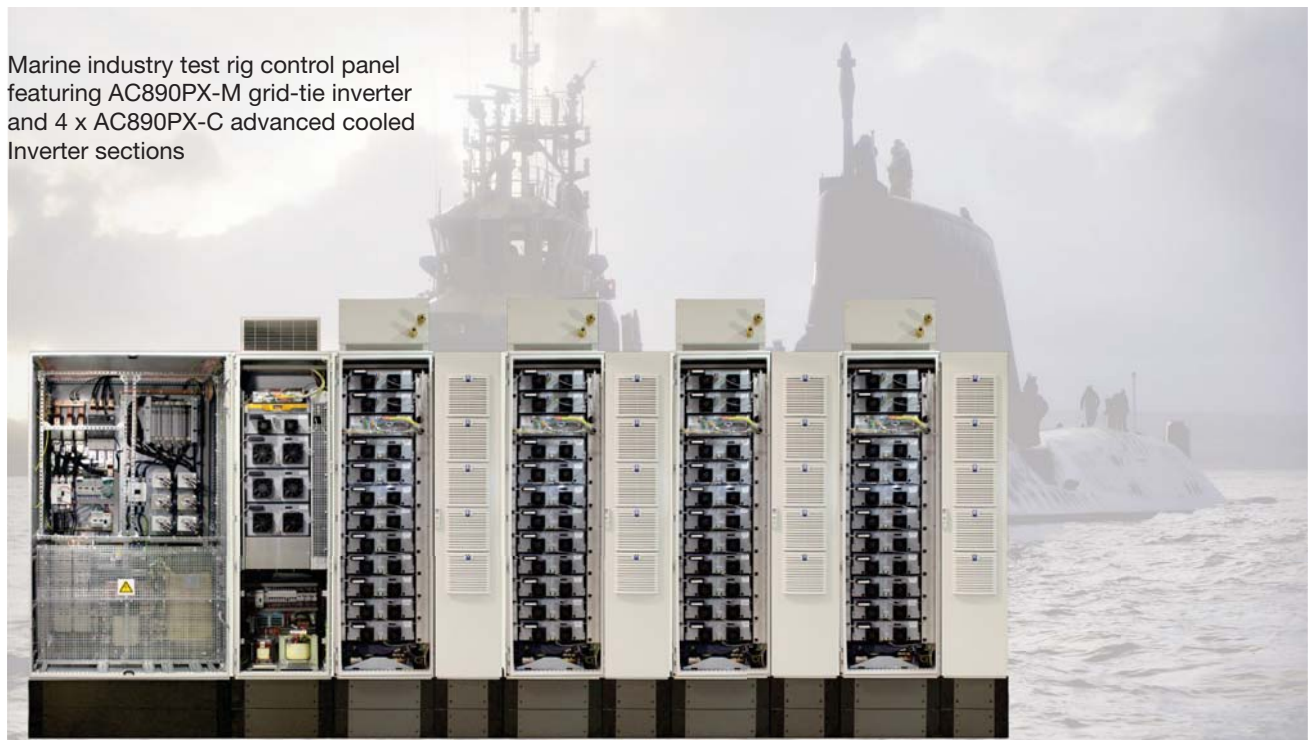

Marine industry test rig control panel featuring AC890PX-M grid-tie inverter and 4 x AC890PX-C advanced cooled Inverter sections

Example Packaged Drive Systems

Energy-Saving Process Control

A pair of drive systems used in a paper mill for process pump and fan control as part of an energy saving system. The system incorporates 60 AC650V drives networked on Profibus.

The larger drives were built into an MCC Form 4 style enclosure.



Dockyard Crane Long-Travel Control

AC890 Series high performance drives were combined to create the long-travel control on a dockyard crane. Operating in a common bus mode with an Active Front End configuration, the system not only provided high dynamic control of the crane but also led to energy-savings and more efficient operation.



Reference Information and Explanation of Abbreviations

Degrees of protection

As defined by IEC60529, the code generally consists of 'IP' followed by two digits, the first describing the protection against solid bodies or protection to persons against contact with live or moving parts inside the enclosure, the second describing the protection against ingress of water.

1 st Digit	Meaning (Protection Against)	2 nd Digit	Meaning (Protection Against)
0	Not protected	0	Not protected
1	50mm dia. body	1	Vertical drips
2	12mm dia. body	2	Drips up to 15° from vertical
3	2.5mm dia. body	3	Drips up to 60° from vertical
4	1mm dia. body	4	Splashing from any direction
5	Dust protected	5	Water jets from any direction
6	Dust tight	6	Heavy seas (Does not cover corrosion resistance etc.)
		7	Effects of immersion
		8	Long periods of immersion under pressure

Cooling Forms

As defined by IEC60034-6, the code generally consists of 'IC' followed by two digits, the first describing the cooling circuit arrangements, the second describing the method of supplying power to circulate the coolant. Where more than one cooling circuit is in use, these may be expressed as 'IC' followed by groups of two digits, eg IC0141.

The following forms are used in this catalogue :

- IC01 - Open machine self-ventilated by fan mounted internally on the shaft.
- IC06 - Open machine ventilated by a blower mounted on the machine.
- IC0041 - Totally enclosed, no external fan.
- IC0141 - Totally enclosed, fan ventilated. Surface cooling by external fan mounted on the shaft.
- IC0641 - Totally enclosed, surface cooled by a blower mounted on the machine.
- IC411 - Totally enclosed fan ventilated. Motor cooled by an external fan.
- IC416 - Totally enclosed force cooled. Motor cooled by an independent fan.

Mounting Forms

The arrangements are defined by IEC60034-7. The following forms are used in this catalogue and are for motors with two bearings housed in endshields. When flange mounting they have access to the back of the flange.

- IM1001 (B3) Horizontal foot mounted
- IM1011 (V5) Vertical foot mounted
- IM3001 (B5) Horizontal flange mounted
- IM3011 (V1) Vertical flange mounted
- IM2001 (B35) Horizontal foot and flange mounted
- IM1071 (B8) Horizontal foot, ceiling mounted

Abbreviations

Electrical Data

Kilowatts	= kW
Volts	= V
Armature Volts	= Va
Field Volts	= Vf
Amperes	= A
Armature Current	= Ia
Field Current	= If
Power Factor	= PF

Useful Conversion Factors

1HP	= 746W
1N.m	= 8.851lb.in
1mm	= 0.3937inch
1m ²	= 35.31ft ²
1kgm ²	= 1Nms ² = 0.73752 lb.ft ²

Useful Formulae

1 Watt = 1Nm/s

$$\text{Torque (lb ft)} = \frac{5250 \times \text{HP}}{\text{speed (rpm)}}$$

$$\text{Torque (Nm)} = \frac{9549 \times \text{kW}}{\text{speed (rpm)}}$$

$$3 \text{ phase AC power (kW)} = \frac{1.732 \times V \times I \times \text{PF}}{1000}$$

$$1 \text{ phase AC power (kW)} = \frac{V \times I \times \text{PF}}{1000}$$

Notes for Gearbox Users - Service Factor

The geared motors covered by this catalogue are rated for driven machines with a uniform load for continuous duty or occasional moderate shock loading on a single-shift operation, being known as a Unity Service Factor. For applications with short-time duty, high inertia or heavy shock loads, advice should be sought on calculating the correct service factor and selecting the most suitable gearbox type.

Useful Servo Drive Calculations

Correctly rating a servo motor and drive application often involved mechanical calculations. Below are typical examples of some of the commonly occurring formula that are often encountered. These are provided for general guidance only and any results may need to be modified to take into account specific application details such as mechanical losses, inclined angles and duty cycles etc. Your local Parker sales office will always be pleased to assist in correctly sizing your application.

Time to accelerate a rotating mass

$M(\text{acc})$ = Acceleration Torque, Nm
 $J(\text{tot})$ = Total Inertia, kgm^2
 $J(\text{mot})$ = Motor Inertia, kgm^2
 $J(\text{load})$ = Load Inertia, kgm^2
 Z = Gearbox Ratio (speed reducing)
 $t(\text{acc})$ = Acceleration time, sec
 α = Angular acceleration, $\text{rad}\cdot\text{sec}^{-2}$
 ω = Angular speed, $\text{rad}\cdot\text{sec}^{-1}$
 n = Angular speed, rpm

$$M(\text{acc}) = J(\text{tot}) \times \alpha \text{ ou } \alpha = M(\text{acc}) / J(\text{tot})$$

$$\alpha = \omega / t(\text{acc}) \text{ ou } t(\text{acc}) = \omega / \alpha$$

$$\omega = (n/60) \times 2\pi$$

$$J(\text{tot}) = J(\text{mot}) + (J(\text{load})/Z^2)$$

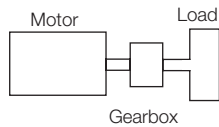

Example

$J(\text{load}) = 0.50\text{kgm}^2$
 $J(\text{mot}) = 5.0\text{kgcm}^2 (=0.00050\text{kgm}^2)$
 $Z = 30:1$
 $n = 1500 \text{ rpm}$
 $M(\text{acc}) = 15\text{Nm}$

$$J(\text{tot}) = 0.00050 + (0.5 / 30^2)$$

$$J(\text{tot}) = 0.00106 \text{ kgm}^2$$

$$\alpha = M(\text{acc})/J(\text{tot})$$

$$\alpha = 15/0.00106$$

$$\alpha = 14150 \text{ rad}\cdot\text{sec}^{-2}$$

$$\omega = (1500/60) \times 2\pi$$

$$\omega = 157 \text{ rad}\cdot\text{sec}^{-1}$$

$$t(\text{acc}) = \omega / \alpha$$

$$t(\text{acc}) = 157/14150$$

$$t(\text{acc}) = 0.0111 \text{ sec (11.1ms)}$$

Useful Inertia Formula

Servo drives are often employed in highly dynamic applications where rapid and accurate positioning is required. To obtain the ultimate performance in any system, the reflected load inertia (taking into account any gearbox or pulley ratio) should equal the motor inertia. This is often not possible, but ratio mismatches of typically 5:1 are not normally significant. The greater the mismatch between reflected load inertia and motor inertia, the lower will be the dynamic performance of the system.

Solid Cylinder Rotating About Axis XX

$$J = (mR^2)/2$$

Hollow Cylinder Rotating About Axis XX

$$J = m(R^2 + r^2)/2$$

Equivalent Inertia of Slide Mass on a Ballscrew

$$J = m(s/2\pi)^2$$

Effect of Gear Ratio on Reflected Inertia

$$J = J(\text{load}) / Z^2$$



Torque Required to Produce a Force on a Leadscrew

M = Required Torque, Nm
 F = Linear Force, N
 Z = Gearbox Ratio (speed reducing)
 ($Z = 1$ for direct drive)
 s = Ballscrew pitch, m
 η = Efficiency

$$M = Fs/2\pi Z\eta$$

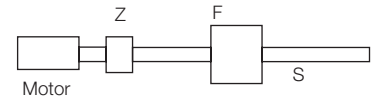

Example

$F = 10000\text{N}$
 $s = 10\text{mm (0.01m)}$
 $Z = 2:1$
 $\eta = 0.9$

Required Motor Torque

$$M = (10000 \times 0.01) / (2\pi \times 2 \times 0.9)$$

$$= 8.85\text{Nm}$$

nb: The required force is often provided in kg's or kgf. This implies the force exerted on the mass by gravity (g) and must be multiplied by 9.81 to obtain the force in N (newtons); eg a «force» of 100kg is 981N).

Product Catalogues



AC10



AC30



AC650



AC650S



AC650G



AC690



AC890



AC890PX-M



Mobile MC



Mobile GVM



Mobile EHP



Analogue DC



DC590+



Fastpack



MS&MR Motors

Market Catalogues



Energy Saving



Motor-Driven Hydraulics



Energy Grid Tie



Offshore & Marine



Parker's Motion & Control Technologies

At Parker, we're guided by a relentless drive to help our customers become more productive and achieve higher levels of profitability by engineering the best systems for their requirements. It means looking at customer applications from many angles to find new ways to create value. Whatever the motion and control technology need, Parker has the experience, breadth of product and global reach to consistently deliver. No company knows more about motion and control technology than Parker. For further info call 00800 27 27 5374



Aerospace

Key Markets

Aftermarket services
Commercial transports
Engines
General & business aviation
Helicopters
Launch vehicles
Military aircraft
Missiles
Power generation
Regional transports
Unmanned aerial vehicles

Key Products

Control systems & actuation products
Engine systems & components
Fluid conveyance systems & components
Fluid metering, delivery & atomization devices
Fuel systems & components
Fuel tank inerting systems
Hydraulic systems & components
Thermal management
Wheels & brakes



Climate Control

Key Markets

Agriculture
Air conditioning
Construction Machinery
Food & beverage
Industrial machinery
Life sciences
Oil & gas
Precision cooling
Process
Refrigeration
Transportation

Key Products

Accumulators
Advanced actuators
CO₂ controls
Electronic controllers
Filter driers
Hand shut-off valves
Heat exchangers
Hose & fittings
Pressure regulating valves
Refrigerant distributors
Safety relief valves
Smart pumps
Solenoid valves
Thermostatic expansion valves



Electromechanical

Key Markets

Aerospace
Factory automation
Life science & medical
Machine tools
Packaging machinery
Paper machinery
Plastics machinery & converting
Primary metals
Semiconductor & electronics
Textile
Wire & cable

Key Products

AC/DC drives & systems
Electric actuators, gantry robots & slides
Electrohydraulic actuation systems
Electromechanical actuation systems
Human machine interface
Linear motors
Stepper motors, servo motors, drives & controls
Structural extrusions



Filtration

Key Markets

Aerospace
Food & beverage
Industrial plant & equipment
Life sciences
Marine
Mobile equipment
Oil & gas
Power generation & renewable energy
Process
Transportation
Water Purification

Key Products

Analytical gas generators
Compressed air filters & dryers
Engine air, coolant, fuel & oil filtration systems
Fluid condition monitoring systems
Hydraulic & lubrication filters
Hydrogen, nitrogen & zero air generators
Instrumentation filters
Membrane & fiber filters
Microfiltration
Sterile air filtration
Water desalination & purification filters & systems



Fluid & Gas Handling

Key Markets

Aerial lift
Agriculture
Bulk chemical handling
Construction machinery
Food & beverage
Fuel & gas delivery
Industrial machinery
Life sciences
Marine
Mining
Mobile
Oil & gas
Renewable energy
Transportation

Key Products

Check valves
Connectors for low pressure fluid conveyance
Deep sea umbilicals
Diagnostic equipment
Hose couplings
Industrial hose
Mooring systems & power cables
PTFE hose & tubing
Quick couplings
Rubber & thermoplastic hose
Tube fittings & adapters
Tubing & plastic fittings



Hydraulics

Key Markets

Aerial lift
Agriculture
Alternative energy
Construction machinery
Forestry
Industrial machinery
Machine tools
Marine
Material handling
Mining
Oil & gas
Power generation
Refuse vehicles
Renewable energy
Truck hydraulics
Turf equipment

Key Products

Accumulators
Cartridge valves
Electrohydraulic actuators
Human machine interfaces
Hybrid drives
Hydraulic cylinders
Hydraulic motors & pumps
Hydraulic systems
Hydraulic valves & controls
Hydrostatic steering
Integrated hydraulic circuits
Power take-offs
Power units
Rotary actuators
Sensors



Pneumatics

Key Markets

Aerospace
Conveyor & material handling
Factory automation
Life science & medical
Machine tools
Packaging machinery
Transportation & automotive

Key Products

Air preparation
Brass fittings & valves
Manifolds
Pneumatic accessories
Pneumatic actuators & grippers
Pneumatic valves & controls
Quick disconnects
Rotary actuators
Rubber & thermoplastic hose & couplings
Structural extrusions
Thermoplastic tubing & fittings
Vacuum generators, cups & sensors



Process Control

Key Markets

Alternative fuels
Biopharmaceuticals
Chemical & refining
Food & beverage
Marine & shipbuilding
Medical & dental
Microelectronics
Nuclear Power
Offshore oil exploration
Oil & gas
Pharmaceuticals
Power generation
Pulp & paper
Steel
Water/wastewater

Key Products

Analytical Instruments
Analytical sample conditioning products & systems
Chemical injection fittings & valves
Fluoropolymer chemical delivery fittings, valves & pumps
High purity gas delivery fittings, valves, regulators & digital flow controllers
Industrial mass flow meters/ controllers
Permanent no-weld tube fittings
Precision industrial regulators & flow controllers
Process control double block & bleeds
Process control fittings, valves, regulators & manifold valves



Sealing & Shielding

Key Markets

Aerospace
Chemical processing
Consumer
Fluid power
General Industrial
Information technology
Life sciences
Microelectronics
Military
Oil & gas
Power generation
Renewable energy
Telecommunications
Transportation

Key Products

Dynamic seals
Elastomeric o-rings
Electro-medical instrument design & assembly
EMI shielding
Extruded & precision-cut, fabricated elastomeric seals
High temperature metal seals
Homogeneous & inserted elastomeric shapes
Medical device fabrication & assembly
Metal & plastic retained composite seals
Shielded optical windows
Silicone tubing & extrusions
Thermal management
Vibration dampening

Parker Worldwide

Europe, Middle East, Africa

AE – United Arab Emirates, Dubai
Tel: +971 4 8127100
parker.me@parker.com

AT – Austria, Wiener Neustadt
Tel: +43 (0)2622 23501-0
parker.austria@parker.com

AT – Eastern Europe, Wiener Neustadt
Tel: +43 (0)2622 23501 900
parker.easteurope@parker.com

AZ – Azerbaijan, Baku
Tel: +994 50 2233 458
parker.azerbaijan@parker.com

BE/LU – Belgium, Nivelles
Tel: +32 (0)67 280 900
parker.belgium@parker.com

BG – Bulgaria, Sofia
Tel: +359 2 980 1344
parker.bulgaria@parker.com

BY – Belarus, Minsk
Tel: +375 17 209 9399
parker.belarus@parker.com

CH – Switzerland, Etoy
Tel: +41 (0)21 821 87 00
parker.switzerland@parker.com

CZ – Czech Republic, Klecany
Tel: +420 284 083 111
parker.czechrepublic@parker.com

DE – Germany, Kaarst
Tel: +49 (0)2131 4016 0
parker.germany@parker.com

DK – Denmark, Ballerup
Tel: +45 43 56 04 00
parker.denmark@parker.com

ES – Spain, Madrid
Tel: +34 902 330 001
parker.spain@parker.com

FI – Finland, Vantaa
Tel: +358 (0)20 753 2500
parker.finland@parker.com

FR – France, Contamine s/Arve
Tel: +33 (0)4 50 25 80 25
parker.france@parker.com

GR – Greece, Athens
Tel: +30 210 933 6450
parker.greece@parker.com

HU – Hungary, Budaörs
Tel: +36 23 885 470
parker.hungary@parker.com

IE – Ireland, Dublin
Tel: +353 (0)1 466 6370
parker.ireland@parker.com

IT – Italy, Corsico (MI)
Tel: +39 02 45 19 21
parker.italy@parker.com

KZ – Kazakhstan, Almaty
Tel: +7 7273 561 000
parker.easteurope@parker.com

NL – The Netherlands, Oldenzaal
Tel: +31 (0)541 585 000
parker.nl@parker.com

NO – Norway, Asker
Tel: +47 66 75 34 00
parker.norway@parker.com

PL – Poland, Warsaw
Tel: +48 (0)22 573 24 00
parker.poland@parker.com

PT – Portugal, Leca da Palmeira
Tel: +351 22 999 7360
parker.portugal@parker.com

RO – Romania, Bucharest
Tel: +40 21 252 1382
parker.romania@parker.com

RU – Russia, Moscow
Tel: +7 495 645-2156
parker.russia@parker.com

SE – Sweden, Spånga
Tel: +46 (0)8 59 79 50 00
parker.sweden@parker.com

SK – Slovakia, Banská Bystrica
Tel: +421 484 162 252
parker.slovakia@parker.com

SL – Slovenia, Novo Mesto
Tel: +386 7 337 6650
parker.slovenia@parker.com

TR – Turkey, Istanbul
Tel: +90 216 4997081
parker.turkey@parker.com

UA – Ukraine, Kiev
Tel +380 44 494 2731
parker.ukraine@parker.com

UK – United Kingdom, Warwick
Tel: +44 (0)1926 317 878
parker.uk@parker.com

ZA – South Africa, Kempton Park
Tel: +27 (0)11 961 0700
parker.southafrica@parker.com

North America

CA – Canada, Milton, Ontario
Tel: +1 905 693 3000

US – USA, Cleveland
Tel: +1 216 896 3000

Asia Pacific

AU – Australia, Castle Hill
Tel: +61 (0)2-9634 7777

CN – China, Shanghai
Tel: +86 21 2899 5000

HK – Hong Kong
Tel: +852 2428 8008

IN – India, Mumbai
Tel: +91 22 6513 7081-85

JP – Japan, Tokyo
Tel: +81 (0)3 6408 3901

KR – South Korea, Seoul
Tel: +82 2 559 0400

MY – Malaysia, Shah Alam
Tel: +60 3 7849 0800

NZ – New Zealand, Mt Wellington
Tel: +64 9 574 1744

SG – Singapore
Tel: +65 6887 6300

TH – Thailand, Bangkok
Tel: +662 186 7000-99

TW – Taiwan, Taipei
Tel: +886 2 2298 8987

South America

AR – Argentina, Buenos Aires
Tel: +54 3327 44 4129

BR – Brazil, Sao Jose dos Campos
Tel: +55 800 727 5374

CL – Chile, Santiago
Tel: +56 2 623 1216

MX – Mexico, Toluca
Tel: +52 72 2275 4200

Parker reserve the right to make any technical changes where necessary. All data is correct at time of printing.
© 2014 Parker Hannifin Corporation. All rights reserved.



EMEA Product Information Centre

Free phone: 00 800 27 27 5374

(from AT, BE, CH, CZ, DE, DK, EE, ES, FI, FR, IE, IL, IS, IT, LU, MT, NL, NO, PL, PT, RU, SE, SK, UK, ZA)

US Product Information Centre

Toll-free number: 1-800-27-27-537

www.parker.com

Your local authorized Parker distributor