

'C' Type 800 Series

Self-feeding with Adjustable Bearing Housing

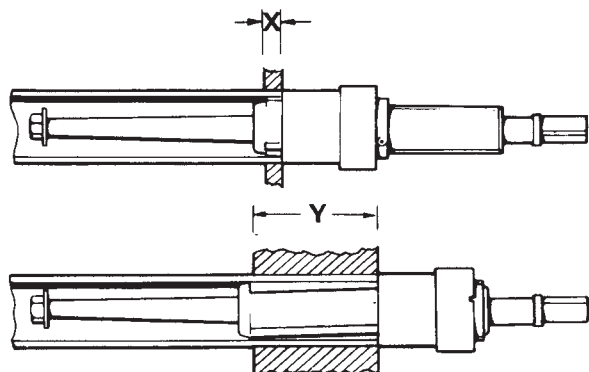

EXPANDER with 1 1/2" (38.10mm) long Rollers

EXPANDER with 2 1/4" (57.15mm) long Rollers

X = 1/2" (12.70mm)
Y = 1 1/2" (38.10mm)

X = 1 1/4" (31.75mm)
Y = 2 1/4" (57.15mm)

Effective parallel rolling length 1 1/4" (31.75mm)

Effective parallel rolling length 2" (50.80mm)



Tube Expanders fitted with 5 rollers are available for expanding thin wall and titanium tubes. Please speak to our sales team for more information.

TABLE RELATING

Tube O.D.	Tube Thickness		Min. I.D. Tube Tool Enters		Maximum Expansion of Tool		Size Sq. on Mandrel		EXPANDER with 1 1/2" (38.10mm) long Rollers			Expander with 2 1/4" (57.15mm) long Rollers			
									Complete Tool No.	Mandrel No.	Set of Rollers No.	Complete Tool No.	Mandrel No.	Set of Rollers No.	
1/2	12.70	14	2.03	.333	8.45	.375	9.52	1/4	6.35	C800S	CM800S	CR0			
1/2	12.70	15	1.83	.344	8.74	.394	10.00	1/4	6.35	C800	CM0	CR0			
1/2	12.70	16	1.63	.360	9.14	.410	10.41	1/4	6.35	C801	CM1	CR1			
1/2	12.70	17	1.42	.374	9.53	.424	10.77	1/4	6.35	C803	CM1	CR2			
1/2	12.70	18	1.22	.392	9.96	.447	11.35	3/8	9.53	C805	CM2	CR3			
1/2	12.70	20	0.88	.410	10.41	.465	11.81	3/8	9.53	C805S	CM2	CR4			
5/8	15.88	12	2.64	.392	9.96	.447	11.35	3/8	9.53	C805	CM2	CR3			
5/8	15.88	13	2.34	.425	10.80	.480	12.19	3/8	9.53	C807	CM3	CR4			
5/8	15.88	14	2.03	.449	11.41	.509	12.93	3/8	9.53	C809	CM4	CR4	C810	CM4	CR4A
5/8	15.88	15	1.83	.471	11.96	.536	13.61	3/8	9.53	C811	CM5	CR5	C812	CM5	CR5A
5/8	15.88	16	1.63	.485	12.33	.550	13.97	3/8	9.53	C813	CM5	CR6	C814	CM5	CR6A
5/8	15.88	17	1.42	.499	12.68	.564	14.33	3/8	9.53	C815	CM6	CR6	C816	CM6	CR6A
5/8	15.88	18	1.22	.517	13.13	.572	14.53	3/8	9.53	C817	CM5	CR7	C818	CM5	CR7A
3/4	19.05	10	3.25	.471	11.96	.536	13.61	3/8	9.53	C811	CM5	CR5	C812	CM5	CR5A
3/4	19.05	11	2.95	.499	12.68	.564	14.33	3/8	9.53	C815	CM6	CR6	C816	CM6	CR6A
3/4	19.05	12	2.64	.522	13.26	.582	14.78	3/8	9.53	C819	CM6	CR7	C820	CM6	CR7A
3/4	19.05	13	2.34	.550	13.97	.615	15.62	3/8	9.53	C821	CM8	CR8	C822	CM8	CR8A
3/4	19.05	14	2.03	.574	14.58	.639	16.23	3/8	9.53	C823	CM8	CR9	C824	CM8	CR9A
3/4	19.05	15	1.83	.596	15.14	.661	16.79	3/8	9.53	C825	CM8	CR10	C826	CM8	CR10A
3/4	19.05	16	1.63	.605	15.37	.685	17.40	3/8	9.53	C827	CM9	CR10	C828	CM9	CR10A
3/4	19.05	17	1.42	.619	15.72	.699	17.75	3/8	9.53	C829	CM9	CR11	C830	CM9	CR11A
3/4	19.05	18	1.22	.619	15.72	.699	17.75	3/8	9.53	C829	CM9	CR11	C830	CM9	CR11A
7/8	22.23	10	3.25	.596	15.14	.661	16.79	3/8	9.53	C825	CM8	CR10	C826	CM8	CR10A
7/8	22.23	11	2.95	.619	15.72	.699	17.75	3/8	9.53	C829	CM9	CR11	C830	CM9	CR11A
7/8	22.23	12	2.64	.642	16.31	.722	18.34	3/8	9.53	C831	CM9	CR12	C832	CM9	CR12A
7/8	22.23	13	2.34	.670	17.02	.750	19.05	3/8	9.53	C833	CM10	CR13	C834	CM10	CR13A

NOTE – Mandrels supplied with square shank unless otherwise specially ordered

WICKSTEED ENGINEERING LIMITED