

Equilibratrici automatiche
per frizioni

Automatic balancing machines
for clutches

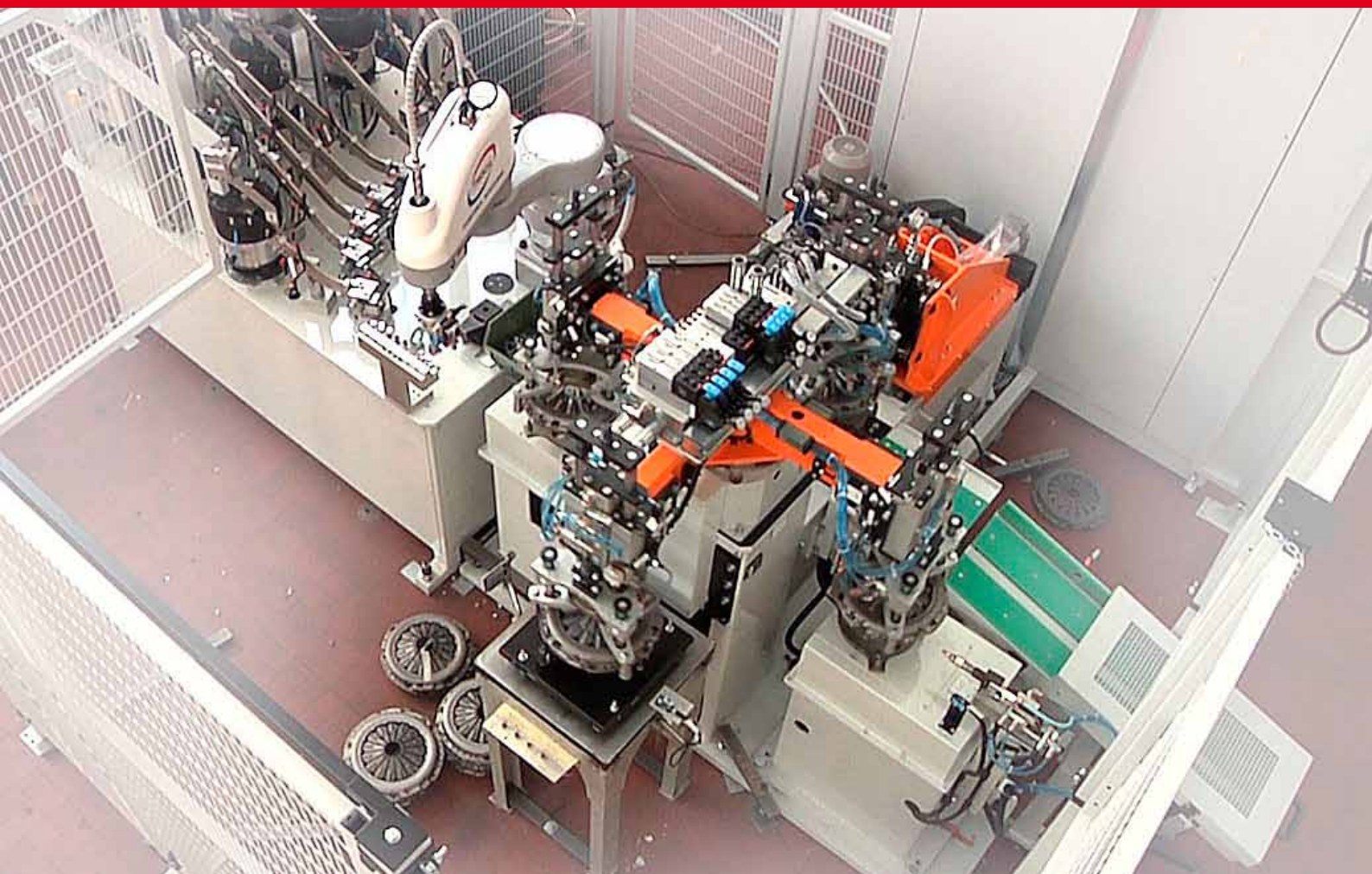

CEMB

BALANCING MACHINES



Equilibratrici automatiche per frizioni

Automatic balancing machines for clutches

VUBS30/PR

Equilibratrice automatica per frizioni completa di pressa di rivettatura. Correzione dello squilibrio mediante aggiunta manuale di rivetti e pressatura eseguita in automatico.

Automatic balancing machine for clutches equipped with riveting press unit. The unbalance correction is obtained by manual adding of suitable weight rivets and automatic pressing operation.



2VUBK30/R/P

Equilibratrice automatica a tre stazioni. Correzione dello squilibrio mediante selezione e inserimento rivetti in automatico tramite robot; pressatura eseguita in automatico su stazione dedicata, lancio di controllo al 100%.

Automatic balancing machine with three stations. The unbalance correction is obtained by automatic selection and placing of rivets by a robot; pressing operation performed automatically on the specific correction, check spin on the 100% of clutches.

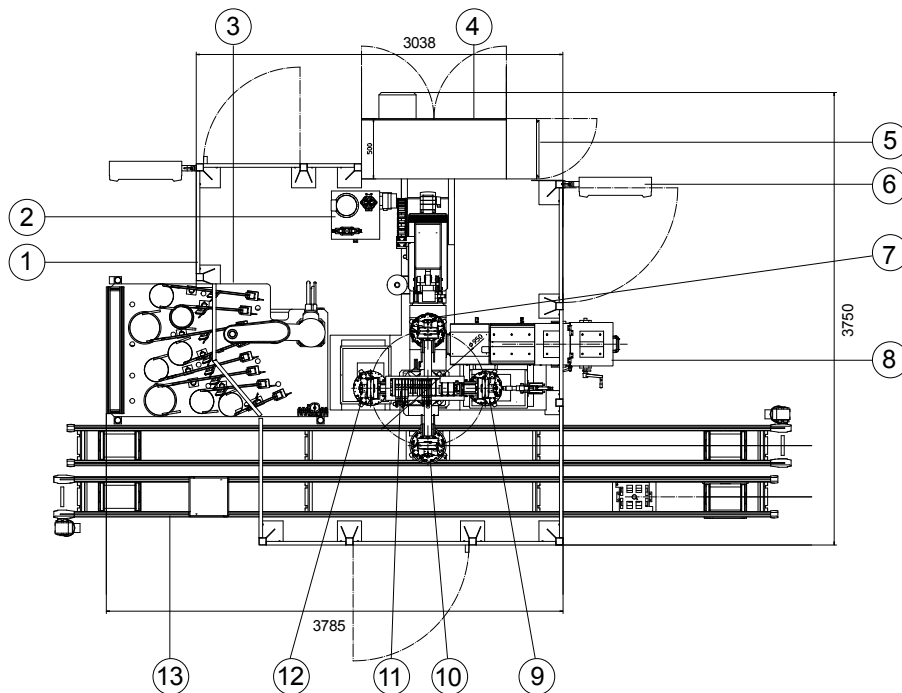

- | | |
|-----|---------------------------------|
| 1. | Safety guard |
| 2. | Oleodynamic device |
| 3. | Rivets loading station |
| 4. | Power cabinet |
| 5. | Pneumatic cabinet |
| 6. | Instrumentation B11 |
| 7. | Pressing station |
| 8. | Reject conveyor |
| 9. | Control balancing and marking |
| 10. | Loading/unloading station |
| 11. | Rotary loading-unloading device |
| 12. | Measuring balancing machine |
| 13. | Conveyor |

Equilibratrici automatiche per frizioni

Automatic balancing machines for clutches

CEMB

VPUBK50/US/UO

Equilibratrice automatica con correzione dello squilibrio mediante foratura orizzontale e/o saldatura di piastrine posizionate in automatico tramite alimentatore lineare.

Automatic balancing machine with unbalance correction by horizontal drilling unit and/or by plates welding machine, automatic positioning of the plates obtained by a linear feeder.

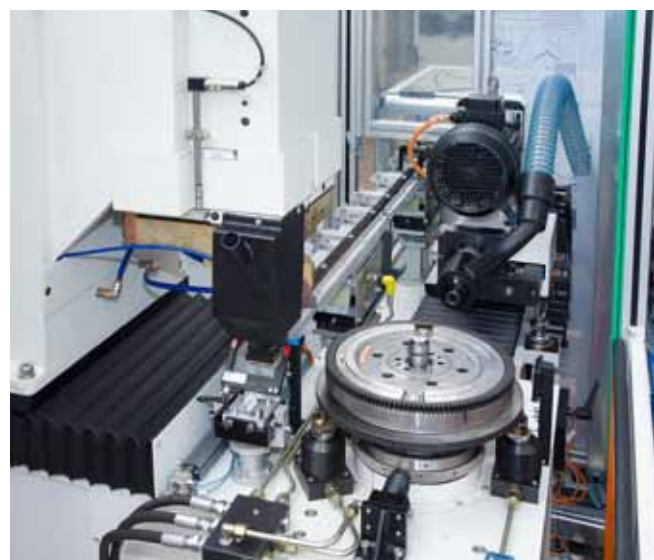

VPUBK100/TO

Impianto automatico per frizioni di camion a 2 stazioni. Correzione mediante foratura e fresatura. Caricatore lineare, 2 assi paralleli. La macchina è equipaggiata di cabina insonorizzante provvista di adeguate finestre per consentire la visibilità della zona di lavoro da parte dell'operatore.

Automatic balancing system for truck clutches with two stations. The unbalance correction is obtained by milling and drilling. Linear loader, two parallel axes. The machine is equipped with soundproof cabin and suitable windows to allow the maximum visibility of the working area by the operator.

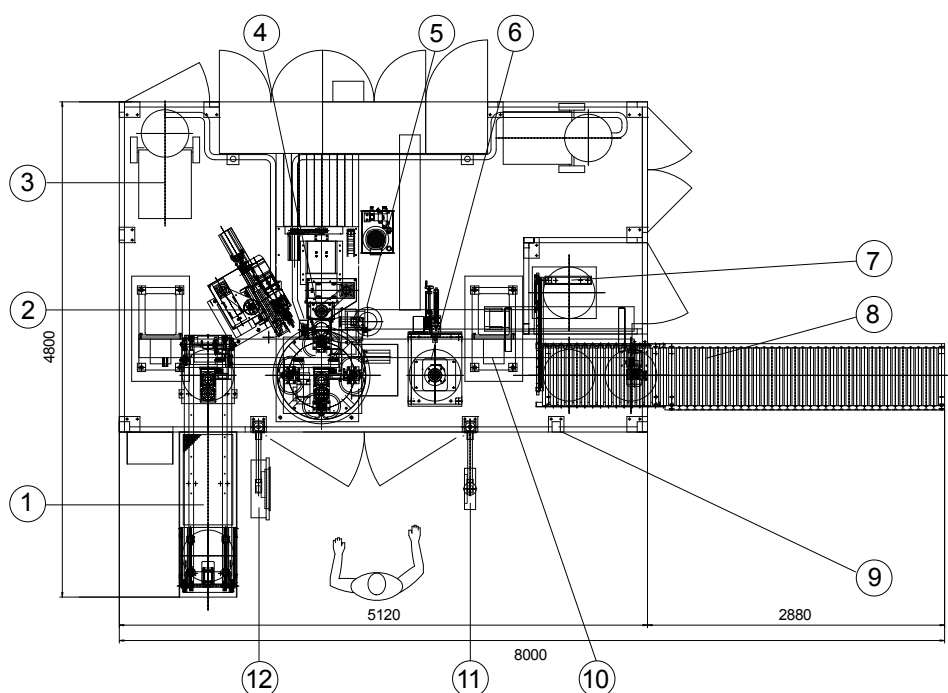

- | | |
|-----|----------------------|
| 1. | Input conveyor |
| 2. | Drilling unit |
| 3. | Swarf extractor |
| 4. | Milling unit |
| 5. | Balancing machine |
| 6. | Marking station |
| 7. | Reject output |
| 8. | Output conveyor |
| 9. | Safety guard |
| 10. | Double gantry loader |
| 11. | Marker panel |
| 12. | Main panel |

**ATTREZZI SPECIALI:
SPECIAL TOOLINGS:**

Attrezzo speciale a forbice per frizioni.

Detail of special tooling for clutches.



VUBK50/UF/A/CN

Equilibratrice automatica per componenti di frizioni con correzione dello squilibrio mediante foratura e/o fresatura in contornatura. Macchina a tre assi controllati.

Automatic balancing machine for parts of clutches with unbalance correction by drilling and/or by contour milling. Machine with three controlled axes.



All the data and features mentioned in this catalogue are purely for information and do not constitute any commitment on the part of our company, which reserves the right to make any and all alterations it may consider suitable without notice.

www.digitmedias.it
AIVS 05 1 12 11/11



CEMB

BALANCING MACHINES



CEMB S.p.A.
Via Risorgimento, 9
23826 MANDELLO DEL LARIO (LC) Italy
www.cemb.com

Industrial balancing division:
phone +39 0341 706111
fax +39 0341 735678
Italy e-mail: industry.it@cemb.com
Export e-mail: industry@cemb.com



TIRGAN

VIBRATION ANALYSIS & CONDITION MONITORING EQUIPMENT

Address: Unit 6, No. 52, Jouybar St.
Tehran - 1415795361, IRAN
Tel: +98-21-88996358-60 Fax: +98-21-88992367
www.cemb-iran.com
info@cemb-iran.com